

中国高端电脑缝纫机

CHINESE HIGH-END COMPUTERIZED SEWING MACHINE

HIKARI® 富山

使用说明书

INSTRUCTION MANUAL

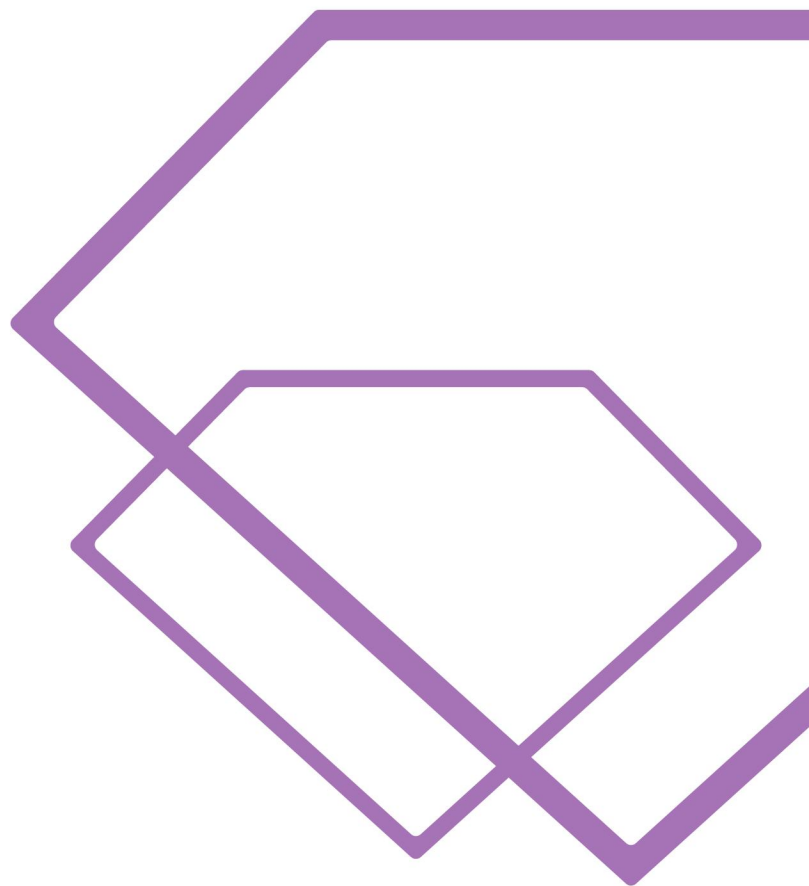

HBH1790 系列
Series

电脑平头锁眼机

COMPUTER STRAIGHT BUTTON HOLING MACHINE

V1.00

非常感谢您购买工业缝纫机。在使用缝纫机之前，请仔细阅读<为了您的安全使用>和使用说明书。



工业缝纫机的特性之一，因为要在机针和挑线杆等运动另部件附近进行作业，而这些另部件很容易引起受伤的危险，所以在受过培训的人或熟练人员的安全操作知识的指导下，正确地使用本缝纫机。

为了您的安全使用

1. 安全使用的标记及其意义

本使用说明书及产品所使用的标记和图案记号是为了您的安全而正确地使用产品，防止您及其他人受到危害和损害。表示方法及含意如下。

说明

 危险	如果忽视此标记而进行了错误的操作，必将导致死亡或重伤。
 注意	如果忽视此标记而进行了错误的操作，有可能会引起人员受伤及造成设备损坏。

图案和符号



.....该符号 (△) 表示 “应注意事项” 。
三角中的图案表示必须要注意的实质内容。
(例如，左边的符号表示 “当心受伤”。)



.....该符号 (⊘) 表示 “禁止” 。



.....该符号 (●) 表示 “必须” 。
圆圈中的图案表示必须要做的事情的实质内容。
(例如，左边的符号表示 “必须接地”。)

[2] 安全注意事项

⚠ 危险

- ⚠ 打开控制箱盖时，先关闭电源开关并将电源插头从插座上拔下后，至少等待 5 分钟后，再打开控制箱盖。触摸带有高电压的区域将会造成人员受伤。

⚠ 注意

使用环境

- ⚠ 请不要在有电源线干扰及静电干扰等有强电气干扰源影响的环境下使用。强电气干扰源可能会影响缝纫机的正确操作。
- ⚠ 电源电压的波动应该在额定电压的 $\pm 10\%$ 以内的环境下使用。电压大幅度的波动会影响缝纫机的正确操作。
- ⚠ 电源容量应大于设备的消耗电量。电源容量不足会影响缝纫机的正确操作。
- ⚠ 压缩空气的供气量应大于设备所要求的总耗气量。压缩空气的供气量不足可能会导致缝纫机的操作不正常。
- ⚠ 环境温度应在 $5^{\circ}\text{C}\sim 35^{\circ}\text{C}$ 的范围内使用。低温或高温会影响缝纫机的正确操作。
- ⚠ 相对湿度应在 $45\%\sim 85\%$ 的范围内，并且设备内不会形成结露的环境下使用。干燥或多湿的环境和结露会影响缝纫机的正确操作。
- ⚠ 万一发生雷电暴风雨时，关闭电源开关，并将电源插头从插座上拔下。雷电可能会影响缝纫机的正确操作。

安装

- ⊘ 请让受过培训的技术人员来安装缝纫机。
- ⚠ 请委托购买商店或电气专业人员进行电气配线。
- ⚠ 缝纫机重量约为 63 Kg。安装工作及调整工作台的高度必须由 4 人以上来完成。
- ⊘ 安装完成前，请不要连接电源。如果误按启动开关，缝纫机动作会导致受伤。
- ⚠ 缝纫机头倒下或竖起时，请用双手进行操作。另外在缝纫机头倒下的状态下，请不要用力压缝纫机。如缝纫机失去平衡，缝纫机(特别是工作台)滑落到地上是造成受伤或缝纫机损坏的原因。
- ⚠ 必须接地。接驳地线不牢固，是造成触电或误动作的原因。
- ⚠ 所有电缆应固定在离活动部件至少 25mm 以外处。另外，不要过度弯曲电缆或用卡钉固定得过紧。会引起火灾或触电的危险。
- ⊘ 请在机头上安装安全罩壳。
- ⚠ 如果使用带小脚轮的工作台，则应该固定小脚轮，使其不能移动。
- ⊘ 使用润滑油时，务必戴好保护眼镜和保护手套等，以防润滑油落入眼中或沾在皮肤上，这是引起发炎的原因。另外，润滑油不能饮用，否则会引起呕吐和腹泻。将油放在小孩拿不到的地方。

⚠ 注意

缝 纫



本缝纫机仅限于接受过安全操作培训的人员使用。



本缝纫机不能用于除缝纫外的任何其他用途。



使用缝纫机时必须戴上保护眼镜。
如果不戴保护眼镜，断针时就会有危险，机针的折断部分可能会弹入眼睛并造成伤害。



发生下列情况时，请切断电源。
否则误按下启动开关时，缝纫机动作会导致受伤。

- 机针穿线时
- 交换机针时
- 缝纫机不使用，或人离开缝纫机时



如果使用带小脚轮的工作台，则应该固定小脚轮使其不能移动。



为了安全起见，在使用本缝纫机之前，请安装保护装置。
如果未安装这些安全装置就使用缝纫机，会造成人身伤害及缝纫机损坏。



缝纫过程中，不要触摸任何运动部件或将物件靠在运动部件上，因为这会导致人员受伤或缝纫机损坏。



如果缝纫机操作中发生误动作，或听到异常的噪音或闻到异常的气味，应立即切断电源。然后请与购买商店或受过培训的技术人员联系。



如果缝纫机出现故障，请与购买商店或受过培训的技术人员联系。

清 洁



清洁前请关闭电源开关。
否则如果误按启动开关，缝纫机动作会导致受伤。



使用润滑油时，务必戴好保护眼镜和保护手套等，以防润滑油落入眼中或沾在皮肤上，这是引起发炎的原因。
另外，润滑油不能饮用，否则会引起呕吐和腹泻。
将油放在小孩拿不到的地方。

维 护 和 检 查



只有经过训练的技术人员才能进行缝纫机的维修、保养和检查。



与电气有关的维修、保养和检查请委托购买商店或电气专业人员进行。



发生下列情况时，请关闭电源。并拔下电源线插座。
否则误按启动开关时，缝纫机动作会导致受伤。

- 检查、调整和维修
- 更换弯针、切刀等易损零部件



在检查、调整和修理任何使用气动装备之前，请先断开气源，并等压力表指针下降到“0”为止。



缝纫机头倒下或竖起时，请用双手进行操作。
另外在缝纫机头倒下的状态下，请不要用力压缝纫机。如缝纫机失去平衡，缝纫机(特别是工作台)滑落到地上是造成受伤或缝纫机损坏的原因。



在必须接上电源开关和气源开关进行调整时，务必十分小心遵守所有的安全注意事项。



请使用公司指定的更换零部件。



取下的安全保护装置，必须要安装。且请务必安装在原位上，并检查能否正常的发挥作用。



未经授权而对缝纫机进行改装而引起的缝纫机损坏不在保修范围内。

Thank you very much for buying a sewing machine. Before using your new machine, please read the safety instructions below and the explanations given in the instruction manual.

With industrial sewing machines, it is normal to carry out work while positioned directly in front of moving parts such as the needle and thread take-up lever, and consequently there is always a danger of injury that can be caused by these parts. Follow the instructions from training personnel and instructors regarding safe and correct operation before operating the machine so that you will know how to use it correctly.



SAFETY INSTRUCTIONS

[1] Safety indications and their meanings

This instruction manual and the indications and symbols that are used on the machine itself are provided in order to ensure safe operation of this machine and to prevent accidents and injury to yourself or other people.

The meanings of these indications and symbols are given below.

Indications

 DANGER	The instructions which follow this term indicate situations where failure to follow the instructions will result in death or serious injury.
 CAUTION	The instructions which follow this term indicate situations where failure to follow the instructions could cause injury when using the machine or physical damage to equipment and surroundings.

Symbols



..... This symbol () indicates something that you should be careful of. The picture inside the triangle indicates the nature of the caution that must be taken.
(For example, the symbol at left means "beware of injury".)



..... This symbol () indicates something that you must not do.



..... This symbol () indicates something that you must do. The picture inside the circle indicates the nature of the thing that must be done.
(For example, the symbol at left means "you must make the ground connection".)

[2] Notes on safety

DANGER



Wait at least 5 minutes after turning off the power switch and disconnecting the power cord from the wall outlet before opening the cover of the control box. Touching areas where high voltages are present can result in severe injury.

CAUTION

Environmental requirements



Use the sewing machine in an area which is free from sources of strong electrical noise such as electrical line noise or static electric noise. Sources of strong electrical noise may cause problems with correct operation.



Any fluctuations in the power supply voltage should be within $\pm 10\%$ of the rated voltage for the machine. Voltage fluctuations which are greater than this may cause problems with correct operation.



The power supply capacity should be greater than the requirements for the sewing machine's power consumption. Insufficient power supply capacity may cause problems with correct operation.



The pneumatic delivery capability should be greater than the requirements for the sewing machine's total air consumption. Insufficient pneumatic delivery capability may cause problems with correct operation.



The ambient temperature should be within the range of 5°C to 35°C during use. Temperatures which are lower or higher than this may cause problems with correct operation.



The relative humidity should be within the range of 45% to 85% during use, and no dew formation should occur in any devices. Excessively dry or humid environments and dew formation may cause problems with correct operation.



In the event of an electrical storm, turn off the power and disconnect the power cord from the wall outlet. Lightning may cause problems with correct operation.

Installation



Machine installation should only be carried out by a qualified technician.



Contact your dealer or a qualified electrician for any electrical work that may need to be done.



The sewing machine weighs approximately 63kg. Use equipment such as a crane or hoist when installing the machine head and adjusting the height of the table. If you try to lift the machine head yourself, it may cause injuries such as back injury.



Do not connect the power cord until installation is complete. If the foot switch is depressed by mistake, the sewing machine might start operating and injury could result.



Hold the machine head with both hands when tilting it back or returning it to its original position. In addition, do not subject the machine head to extra force while it is tilted back. If this is not observed, the machine head may become unbalanced and fall down, and serious injury or damage to the sewing machine may result.



Be sure to connect the ground. If the ground connection is not secure, you run a high risk of receiving a serious electric shock, and problems with correct operation may also occur.



All cords should be secured at least 25 mm away from any moving parts. Furthermore, do not excessively bend the cords or secure them too firmly with staples, otherwise there is the danger that fire or electric shocks could occur.



Install the safety covers to the machine head and motor.



If using a work table which has casters, the casters should be secured in such a way so that they cannot move.











Use a table with a height of 84 cm or less. If the table is too high, the machine head may become unbalanced and fall down, and serious injury or damage to the sewing machine may result.





Be sure to wear protective goggles and gloves when handling the lubricating oil and grease, so that they do not get into your eyes or onto your skin. If the oil and grease get into your eyes or onto your skin, inflammation can result. Furthermore, do not drink or eat the lubricating oil or grease. They may cause diarrhea or vomiting. Keep the oil out of the reach of children.

CAUTION









Sewing

-  This sewing machine should only be used by operators who have received the necessary training in safe use beforehand.
-  The sewing machine should not be used for any applications other than sewing.
-  Be sure to wear protective goggles when using the machine.
If goggles are not worn, there is the danger that if a needle breaks, parts of the broken needle may enter your eyes and injury may result.
-  Turn off the power switch at the following times. If the foot switch is depressed by mistake, the sewing machine might start operating and injury could result.
 - When threading the needle
 - When replacing the bobbin and needle
 - When not using the machine and when leaving the machine unattended
-  If using a work table which has casters, the casters should be secured in such a way so that they cannot move.
-  Attach all safety devices before using the sewing machine. If the machine is used without these devices attached, injury may result.
-  Do not touch any of the moving parts or press any objects against the machine while sewing, as this may result in personal injury or damage to the machine.
-  If an error occurs in machine operation, or if abnormal noises or smells are noticed, immediately turn off the power switch. Then contact your nearest Brother dealer or a qualified technician.
-  If the machine develops a problem, contact your nearest dealer or a qualified technician.

Cleaning

-  Turn off the power switch before carrying out cleaning. If the foot switch is depressed by mistake, the sewing machine might start operating and injury could result.
-  Be sure to wear protective goggles and gloves when handling the lubricating oil and grease, so that they do not get into your eyes or onto your skin. If the oil and grease get into your eyes or onto your skin, inflammation can result.
Furthermore, do not drink or eat the lubricating oil or grease. They may cause diarrhea or vomiting.
Keep the oil out of the reach of children.

Maintenance and inspection

-  Maintenance and inspection of the sewing machine should only be carried out by a qualified technician.
-  Ask your dealer or a qualified electrician to carry out any maintenance and inspection of the electrical system.
-  Turn off the power switch and disconnect the power cord before carrying out the following operations. If the foot switch is depressed by mistake, the sewing machine might start operating and injury could result.
 - Inspection, adjustment and maintenance
 - Replacing consumable parts such as the rotary hook
-  Disconnect the air hoses from the air supply and wait for the needle on the pressure gauge to drop to "0" before carrying out inspection, adjustment and repair of any parts which use the pneumatic equipment.
-  Hold the machine head with both hands when tilting it back or returning it to its original position.
In addition, do not subject the machine head to extra force while it is tilted back. If this is not observed, the machine head may become unbalanced and fall down, and serious injury or damage to the sewing machine may result.
-  If the power switch and air need to be left on when carrying out some adjustment, be extremely careful to observe all safety precautions.
-  Use only the proper replacement parts as specified.
-  If any safety devices have been removed, be absolutely sure to re-install them to their original positions and check that they operate correctly before using the machine.
-  Any problems in machine operation which result from unauthorized modifications to the machine will not be covered by the warranty.

目 录

1. 主要零部件的名称	1
2. 规格	2
2-1. 缝纫规格	2
2-2. 标准缝制形状一览表	2
3. 安装方法	4
3-1. 机台的组装	4
3-2. 电源线的连接	5
3-3. 缝纫机主体安装	6
3-4. 缝纫机的放倒方法	6
3-5. 安全开关的连接	7
3-6. 旋梭防油板的安装	7
3-7. 操作盘的安装	7
3-8. 电缆的连接	8
3-9. 电线的处理	9
3-10. 眼睛保护罩的安装	9
3-11. 暂停开关的固定	10
3-12. 导线杆	10
3-13. 线架装置的安装	10
4. 缝纫前的准备	11
4-1. 加油	11
4-2. 机针的安装方法	12
4-3. 上线的安装方法	13
4-4. 梭壳的穿线方法	14
4-5. 底线张力的调整	15
4-6. 梭壳的安装方法	15
4-7. 切刀的安装方法	16
5. 缝纫机的操作	17
5-1. 操作盘的开关说明	17
5-2. 缝纫机的基本操作	19
5-3. 踏板的操作方法	19
5-4. 输入压脚类型	21
5-5. 选择图案	22
5-6. 变更上线的约力	23
5-7. 修理缝制时	24
5-8. 绕底线	25
5-9. 使用计数器	26
5-10. 使用初期值模式	27
5-11. 变更缝制数据	28
5-12. 缝制数据编辑有/无的设定方法	29
5-13. 缝制数一览表	30
5-14. 复制缝制图案	35
5-15. 使用图案登记键	36
5-16. 使用参数登记键时	36
5-17. 进行连续缝制时	37
5-18. 进行循环缝制时	39
5-19. 切刀数次动作的说明	40
5-20. 存储开关数据的变更方法	42
5-21. 存储器开关数据一览表	43
6. 保养	47
6-1. 机针和旋梭的同步调整	47
6-2. 上线切线的调整	48
6-3. 布压脚压力的调	48
6-4. 旋梭压片装置的调	49
6-5. 线张力	49
5-6. 滤清器的清扫	50
5-7. 保险丝的更换	50
7. 标准部件	51
7-1. 切布刀	51
7-2. 货号	51
7-3. 压脚	51
8. 错误代码	52

CONTENTS

1. NAMES OF MAJOR PARTS	1
2. SPECIFICATIONS	2
2-1.Specifications	2
2-2.Standard sewing shape list	2
3. INSTALLATION	4
3-1.Set-up of table	4
3-2.Connecting the power source cord.....	5
3-3.Changing the voltage of 100/200.....	6
3-4.Installing the sewing machine main unit.....	7
3-5.Tilting the sewing machine head	7
3-6.Connecting the safety switch connector.....	8
3-7.Installing the hook oil shield plate	8
3-8.Installing the operation panel	8
3-9.Connecting the cords.....	9
3-10.Managing the cord	10
3-11.Installing the eye protection cover	10
3-12.Fixing the temporary stop switch	11
3-13.Thread guide rod.....	11
3-14.Installing the thread stand	11
4. PREPARATION BEFORE OPERATION	12
4-1.Lubrication	12
4-2.Inserting the needle	12
4-3.Threading the needle-thread	13
4-4.Threading the bobbin case	13
4-5.Adjusting the bobbin thread tension	14
4-6.Installation of bobbin case	14
4-7.Installing the knife	15
5. OPERATION OF THE SEWING MACHINE	16
5-1.Explanation of the operation panel switch	17
5-2.Basic operation of the sewing machine.....	18
5-3.How to use the pedal	18
5-4.Input of the presser type	20
5-5.Performing pattern selection	21
5-6.Changing needle thread tension.....	22
5-7.Performing re-sewing	23
5-8.Winding bobbin thread	24
5-9.Using the counter	25
5-10.Using the initial value pattern	26
5-11.Changing sewing data	27
5-12.Method of setting sewing data with/without edit.....	28
5-13.Sewing data list	29
5-14.Copying sewing pattern	34
5-15.Using pattern register key	35
5-16.Using parameter register key	36
5-17.Performing continuous stitching	37
5-18.Performing cycle stitching	39
5-19.Explanation of plural motions of knife	40
5-20.Method of changing memory switch data	42
5-21.Memory switch data list	42
6. MAINTENANCE	47
6-1.Adjusting the needle-to-hook relation.....	47
6-2.Adjusting the needle thread trimmer	48
6-3.Adjusting the presser bar pressure.....	49
6-4. Adjusting of the bobbin presser unit	49
6-5.Thread tension	49
5-6.Cleaning the filter	50
5-7.Replacing the fuse.....	50
7. GWUGE COMPONENTS	52
7-1.Cloth cutting knife	52
7-2.Throat plate.....	51
7-3.Presser.....	51
8. ERROR CODE LIST	52

1、主要零部件的名称

1、主要零部件的名称

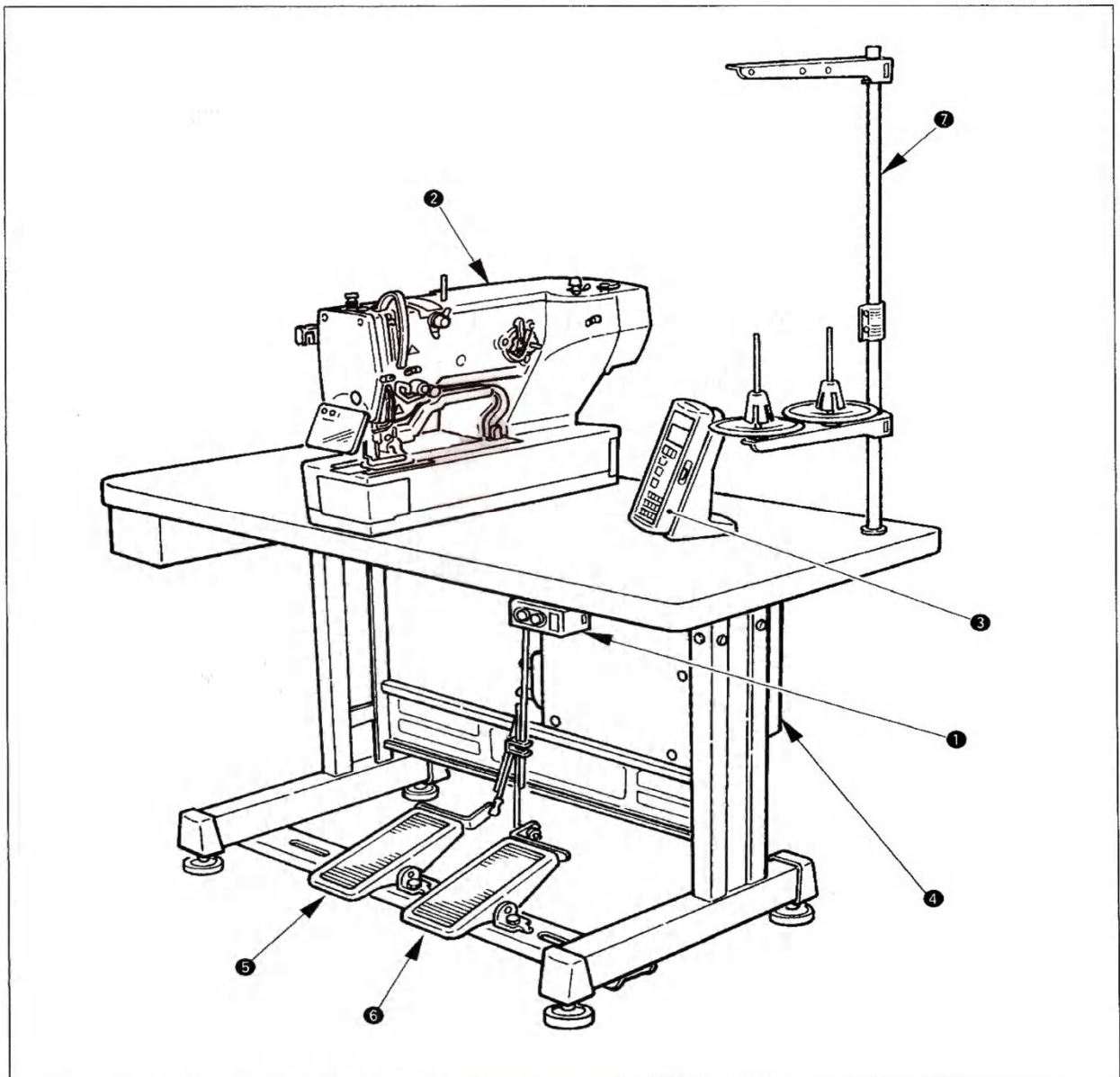

CSM-1790 由以下部分所构成。

















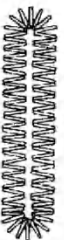

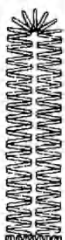





①	电源 ON/OFF 开关
②	缝纫机机头 (CSM-1790)
③	操作盘
④	电气箱
⑤	压脚提升踏板
⑥	起动踏板
⑦	线架装置

2、规格





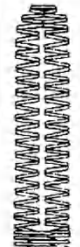









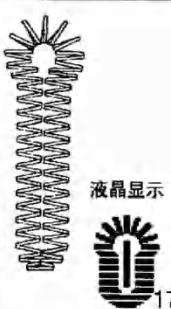



2-1. 缝纫规格

	CSM-1790S	CSM-1790K
缝纫机速度	标准速度：3600rpm(最高：4200rpm) (使用干式旋梭时最高：4200rpm)	
使用机针	DPx5 #11J~#14J	
使用旋梭	DP 型全旋转旋梭	
摆针驱动方式	驱动脉冲马达	
送针驱动方式	驱动脉冲马达	
压脚提升驱动方式	驱动脉冲马达	
压脚提升量	14mm(可以任意设定)最大：17mm(倒转针提升时)	
切布刀驱动方式	复数电磁驱动	
主要用途	衬衣、衬衫、工作服、女装等棉布纽扣眼	针织内衣、毛衣、羊毛衫、平针针织物等针织的纽扣眼
纽扣扣眼尺寸	标准宽度：最大 5mm；特别规格零件：最大 10mm 使用切刀尺寸：6.4~31.8mm(1/4' ~ 1-1/4') 开孔缝制长度：标准最大 41mm；特别规格零件最大 120mm	
标准缝制形状	30 种	
记忆图案数	99 图案	
电源	单相 220/230/240V、1000VA	

2-2. 标准缝制形状一览表

(1) 角型	(2) 圆型	(3) 辐射角型	(4) 辐射型	(5) 辐射直线加固型	(6) 辐射锥形加固型
 液晶显示  1	 液晶显示  2	 液晶显示  3	 液晶显示  4	 液晶显示  5	 液晶显示  6
(7) 圆头扣眼角型	(8) 圆头扣眼辐射型	(9) 圆头扣眼直线加固型	(10) 圆头扣眼锥形加固型	(11) 半月型	(12) 圆角型
 液晶显示  7	 液晶显示  8	 液晶显示  9	 液晶显示  10	 液晶显示  11	 液晶显示  12

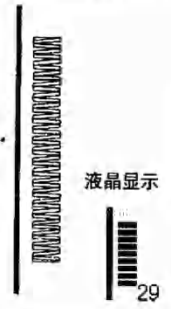
2. 规格

(13) 半月角型	(14) 半月直线加固型	(15) 半月锥形加固型	(16) 圆头扣眼半月型	(17) 圆头扣眼圆型	(18) 角辐射型
					
(19) 角半月型	(20) 角圆型	(21) 角直线加固型	(22) 角锥形加固型	(23) 辐射半月型	(24) 辐射圆型
					
(25) 半月辐射型	(26) 半月圆型	(27) 加固缝	(28) 加固右切断	(29) 加固左切断	(30) 加固中央切断
					

3. 安装方法

3-1. 机台的组装



危险

搬运缝纫机时，请至少 2 人以上进行。

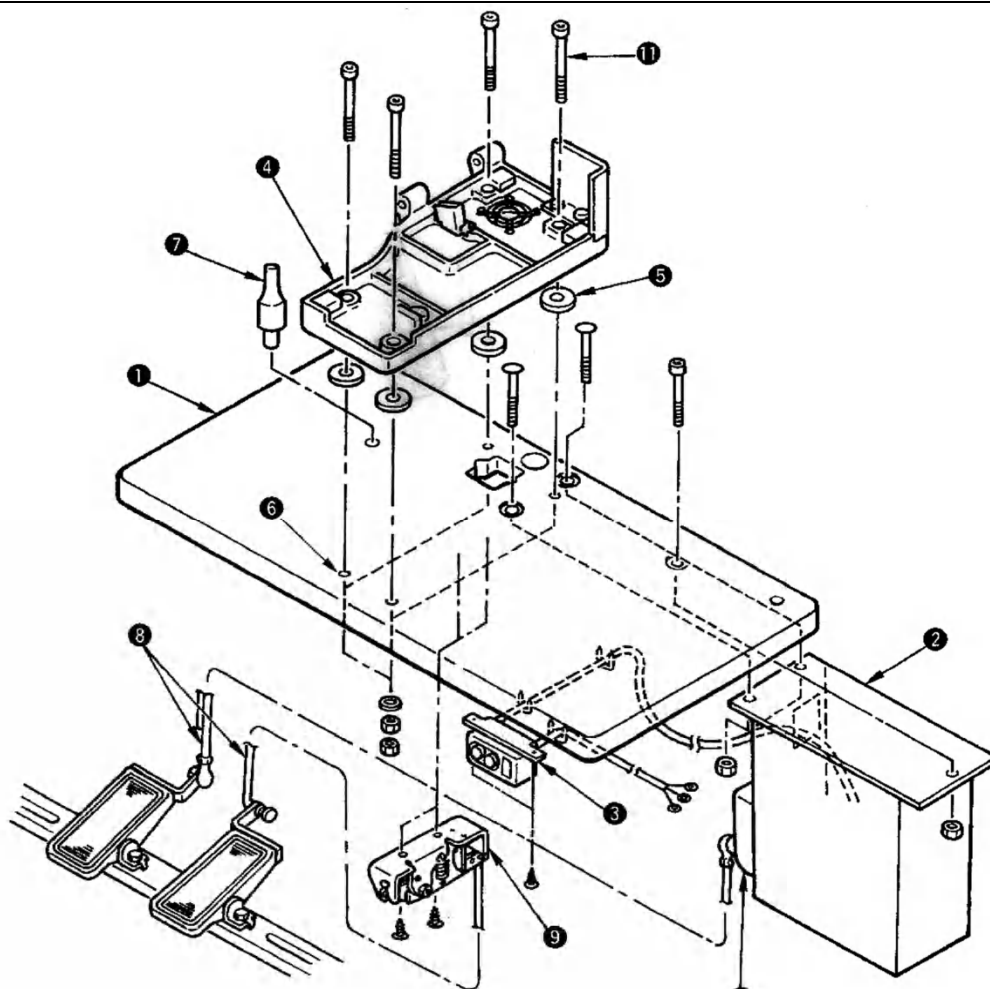

- 1) 把控制箱 ②、电源开关 ③ 固定到机台 ① 上。
- 2) 用固定条把电源开关 ③ 的电缆线固定起来。
- 3) 把机台固定螺丝 ⑪ (4 个) 穿过机头座 ④。
- 4) 把减震橡胶 ⑤ 安装到机台的机头座固定孔 ⑥ (4 处)，然后固定机头座 ④。
- 5) 把机头支撑杆 ⑦ 固定到机台 ① 上。
- 6) 把缝纫机主机放到机台 ④ 上后，把踏板 (右侧) 和踏板开关 ⑨、踏板 (左侧) 和电气踏板传感器 ⑩ 用附属的连接杆 ⑧ 分别连接起来。



请调整踏板位置，不让连接杆 ⑧ 和控制箱 ② 相碰。

3. 安装方法

3-2. 电源线的连接

电压规格

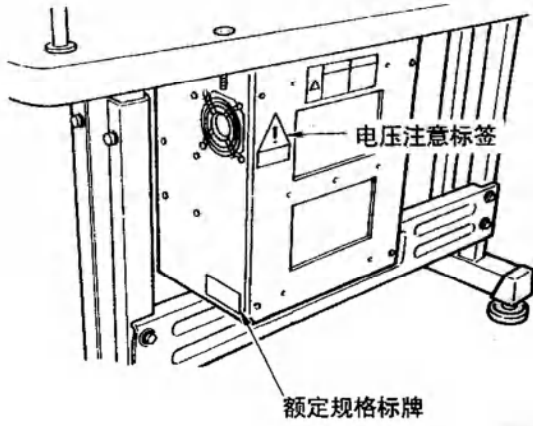

规格请参看电压注意标签和额定规格标牌。
请根据规格选接电线。

单相 200V、220V、230V 和 240V 的连接

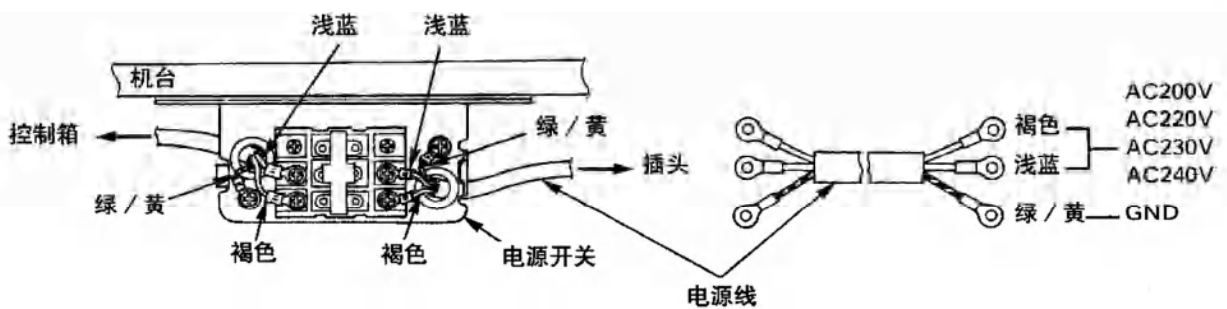

在电压规格不同的状态下绝对不能使用。

3-3. 缝纫机主体安装

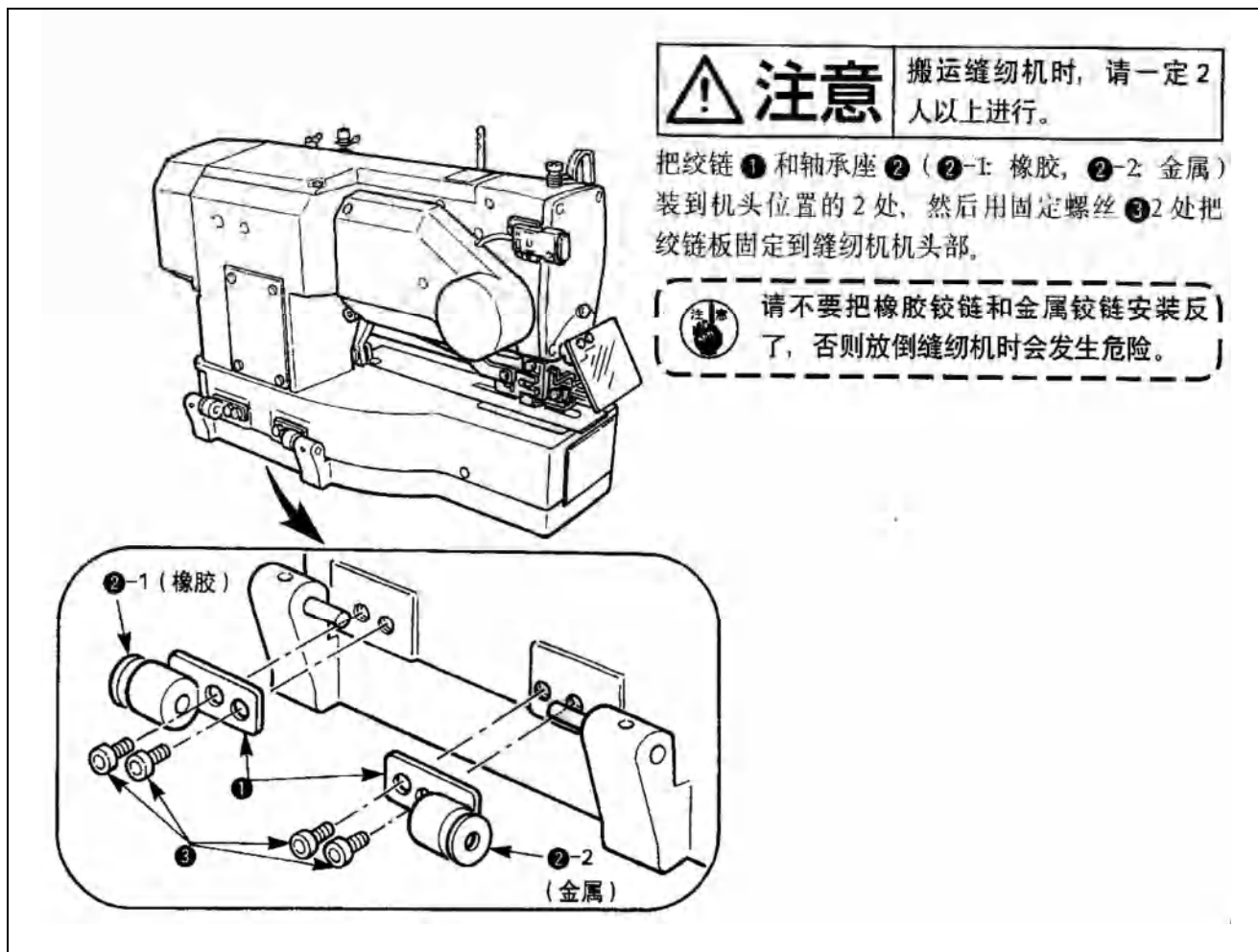

3-4. 缝纫机的放倒方法



3. 安装方法

3-5. 安全开关的连接

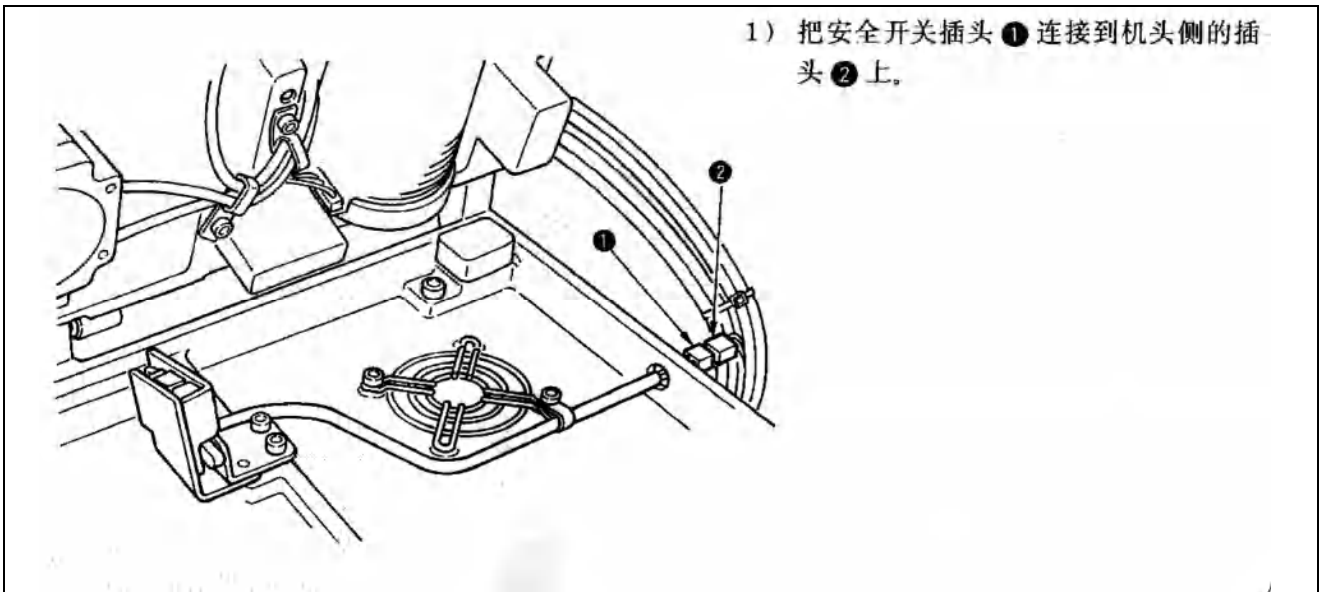

3-6. 旋梭防油板的安装

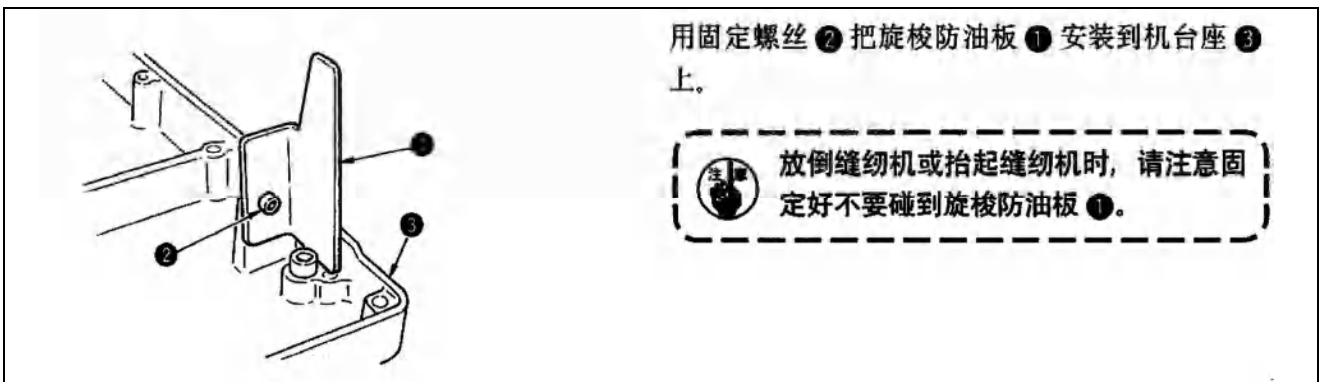

3-7. 操作盘的安装

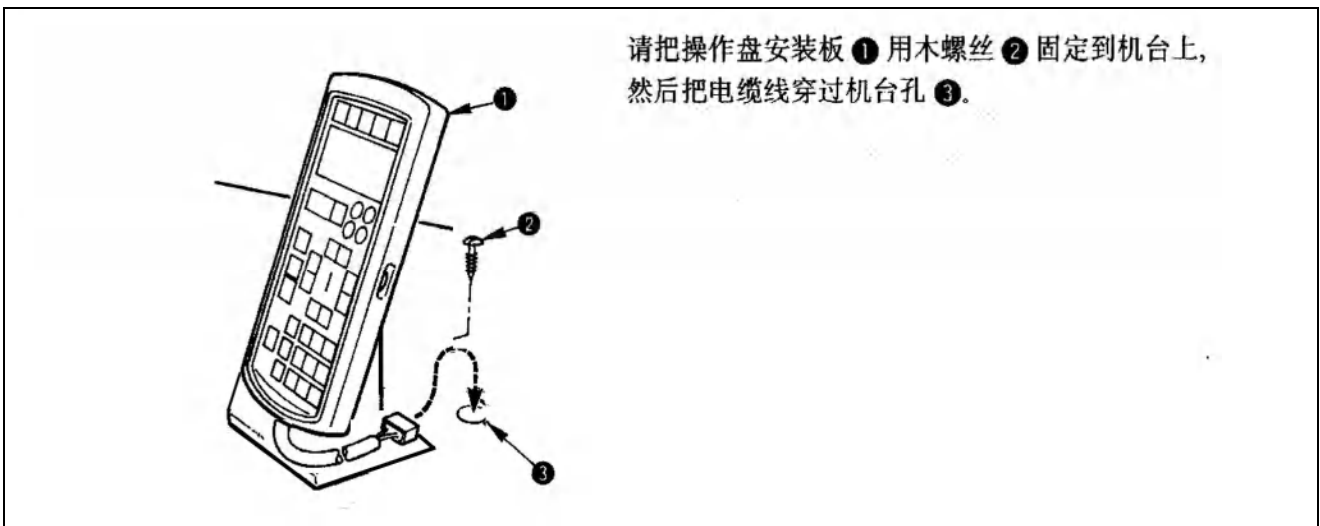

3-8. 电缆的连接

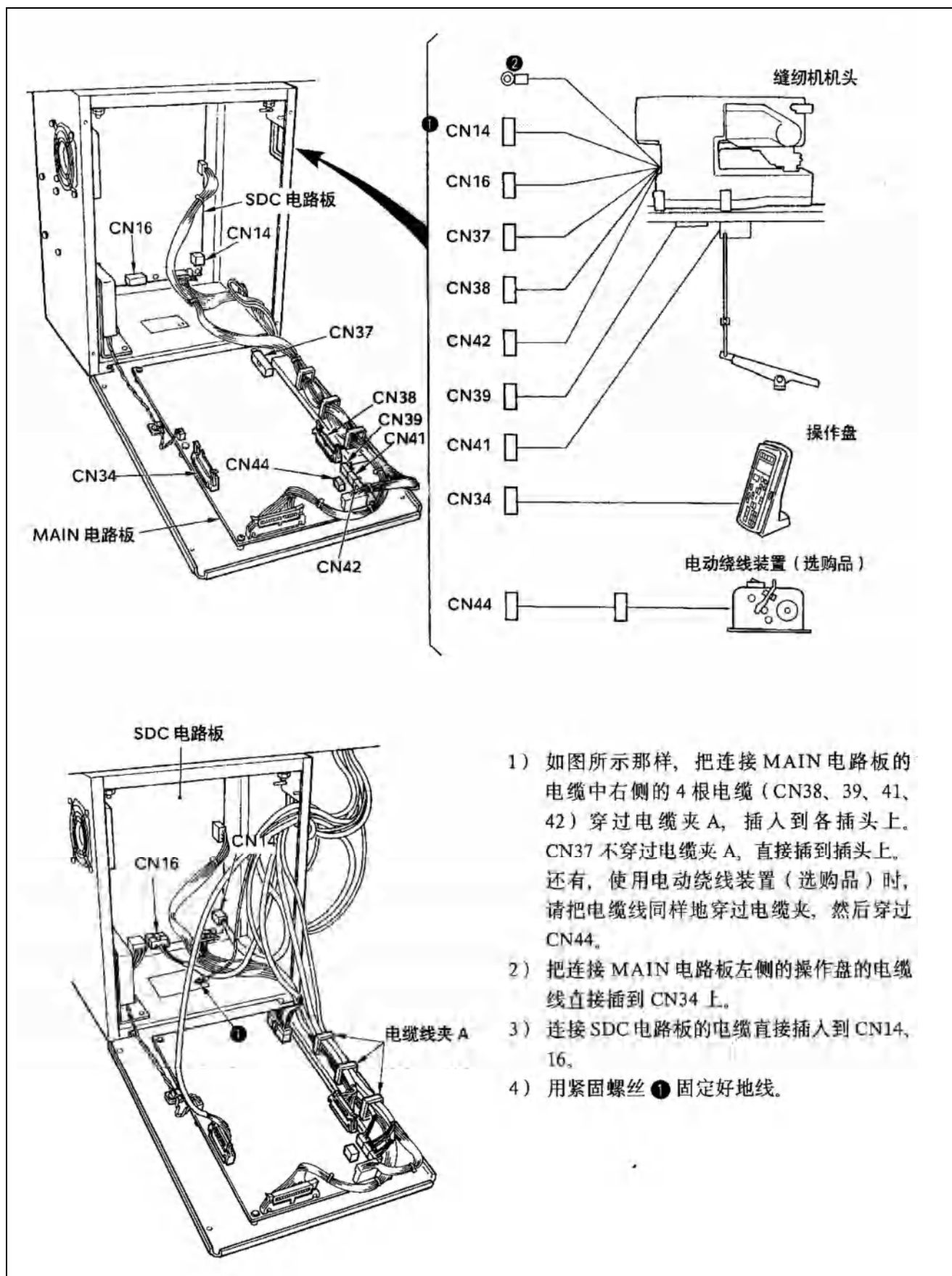

3. 安装方法

3-9. 电线的处理

- 1) 请一边慢慢地放倒缝纫机，一边确认电缆没有被勾住。
- 2) 如图所示，用电线固定板 ❶ 固定电线。



放倒缝纫机时，请确机头支杆 ❷ 安装在机台上。

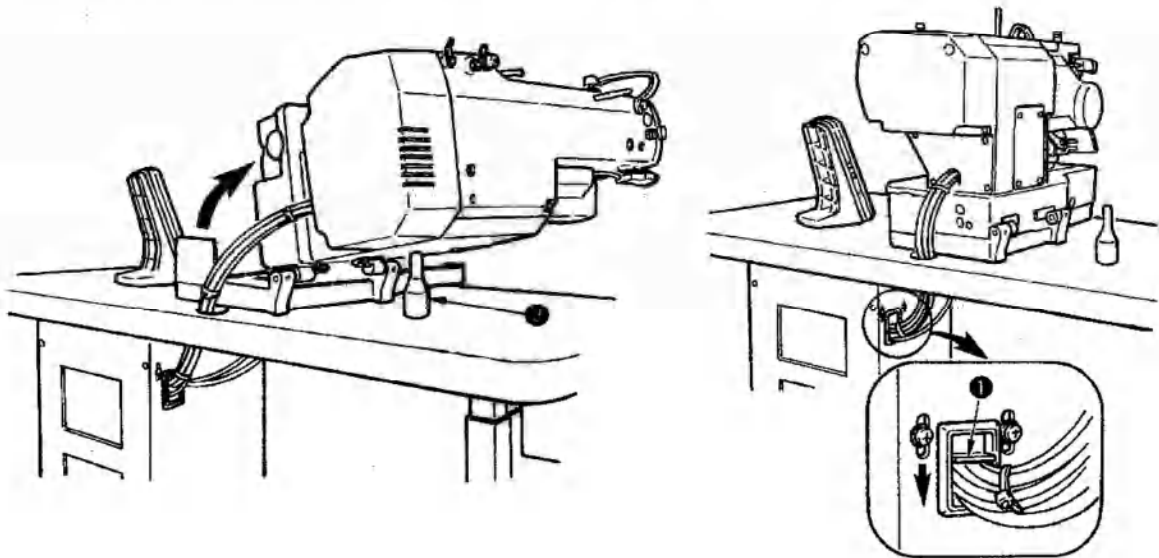

3-10. 眼睛保护罩的安装



危险

为了保护断针飞起弄伤眼睛，请一定安装起来。

请一定安装眼睛保护罩 ❶ 后再使用缝纫机。

竖立设置时

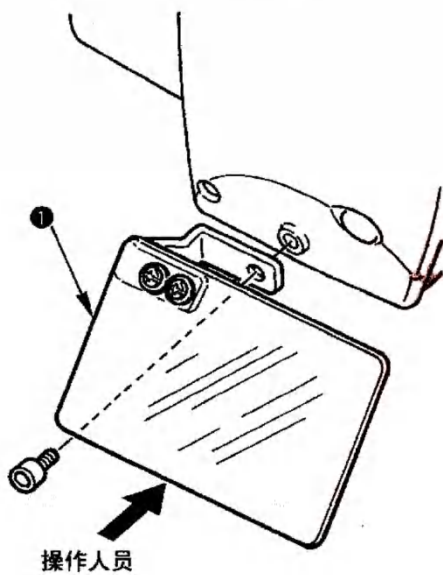

横向设置时

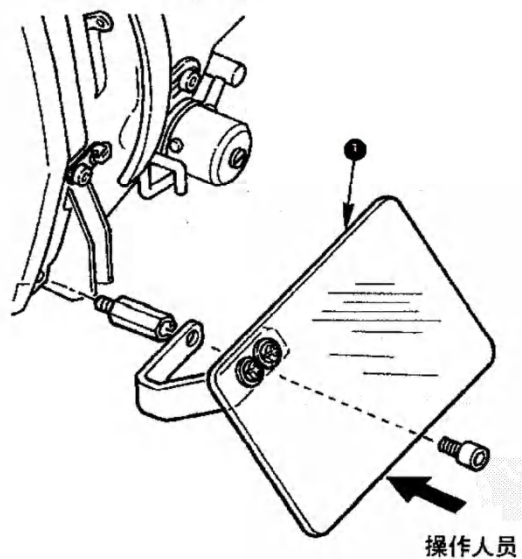

3-11. 暂停开关的固定

出货时，暂停开关为 A 的状态，请拧松固定螺丝 ①，变更为 B 状态，然后用附属的固定螺丝 ② 和固定螺丝 ① 固定好。

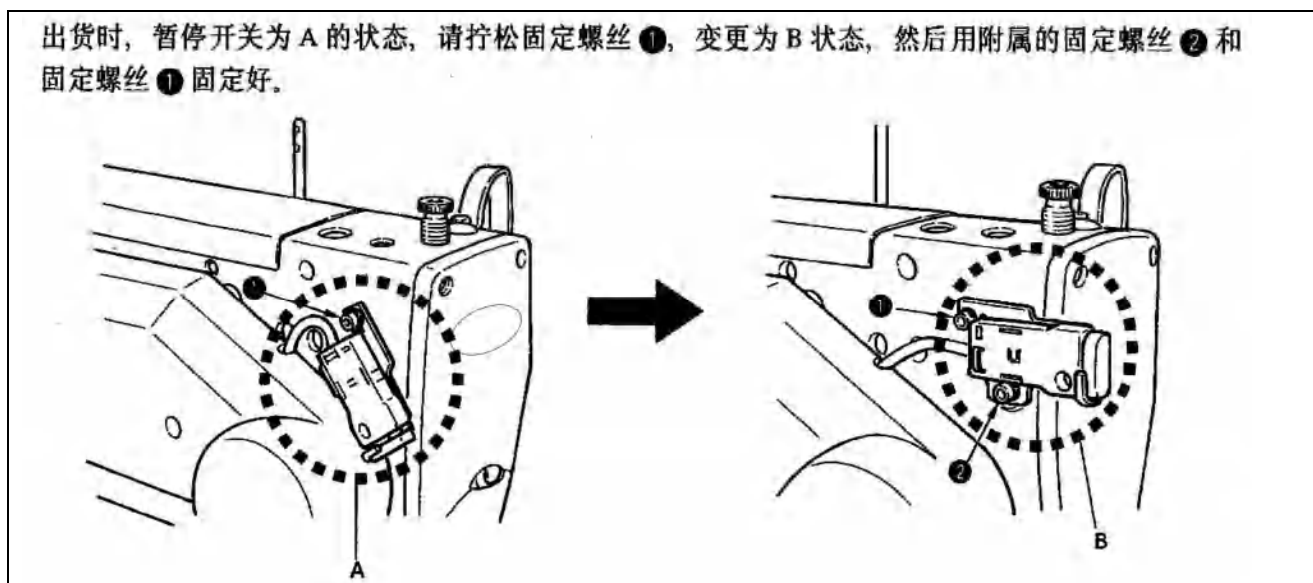

3-12. 导线杆

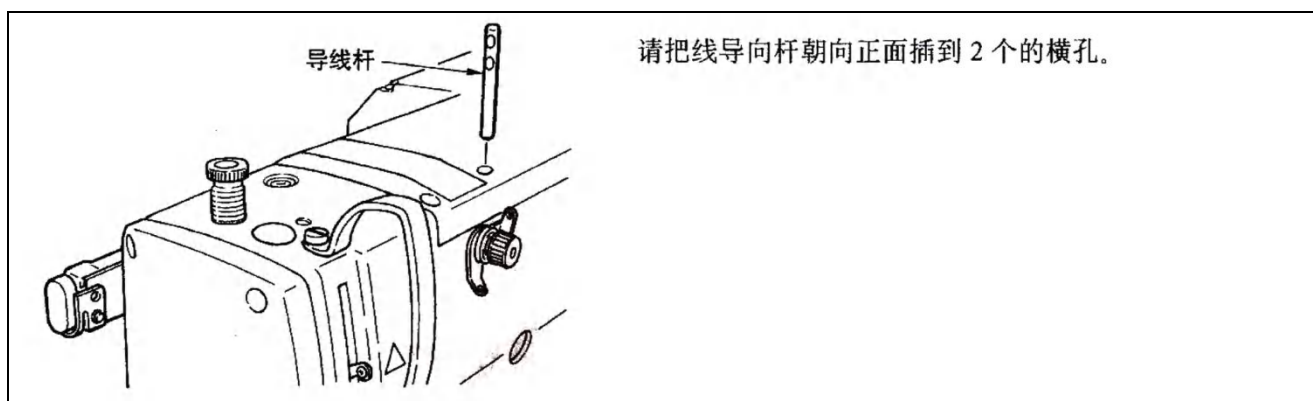

3-13. 线架装置的安装

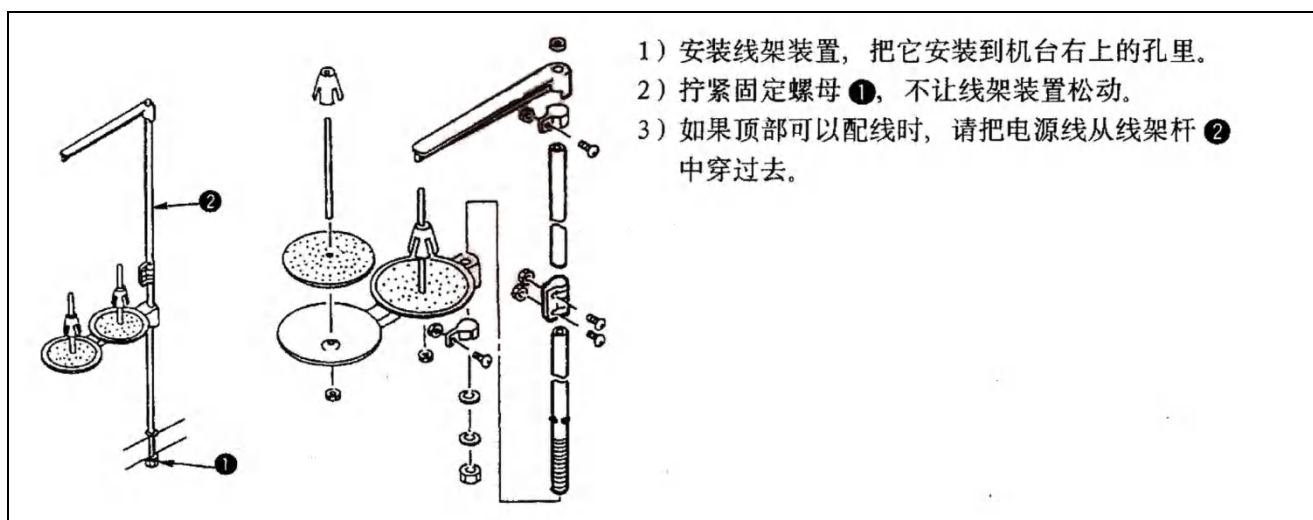

4. 缝纫前的准备

4、缝纫前的准备

4-1. 加油



注意

为了防止突然起动造成人身事故，请关掉电源，确认马达确实停止转动后再进行操作。

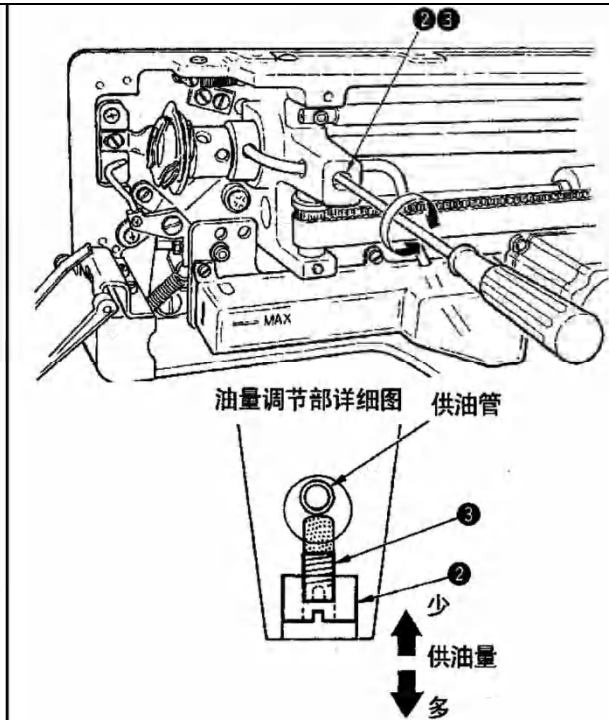
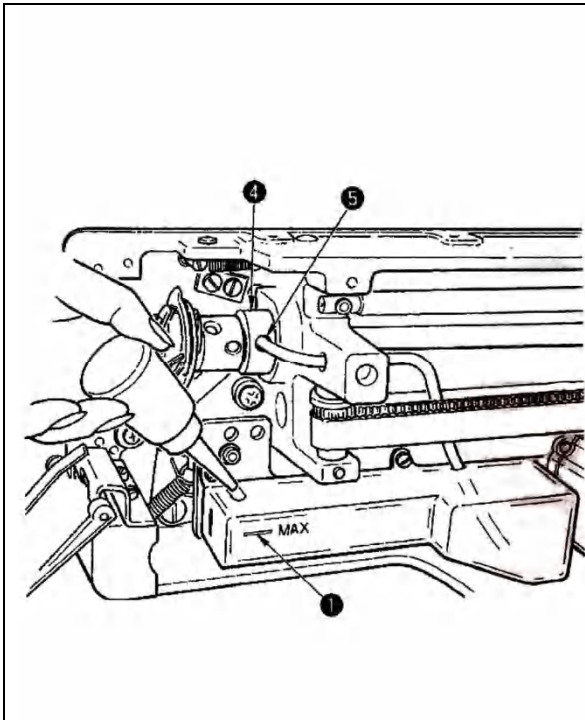

1) 向加油罐里加油

- 把 New Flex Oil No.1 机油加满到 MAX 记号的位置 ①。

2) 旋梭油量的调整

- 拧松油量调节固定螺母 ②，然后用油量调整螺丝 ③ 进行调节。
- 调节旋梭的油量时，拧紧油量调节螺丝 ③ 则油量减少。
- 油量调整后，请用固定螺母 ② 进行固定。
- 新装缝纫机或较长时间没有用过的缝纫机，使用之前请取下梭壳，在旋梭边槽加 2 ~ 3 滴机油。另外，向下轴前金属部件 ④ 的加油孔 ⑤ 加几滴油，把油浸润到里面的毛毡里。

4-2. 机针的安装方法

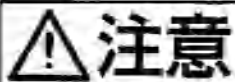

注意

为了防止突然起动造成人身事故，请关掉电源，确认马达确实停止转动后再进行操作。

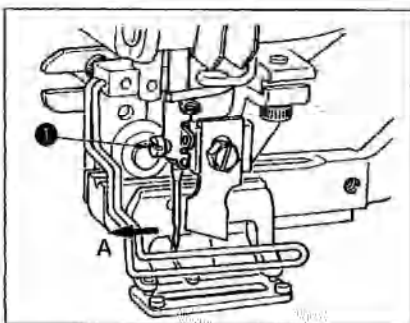

从缝纫机正面看，把机针凹部横向转到前侧 A。
然后把机针插进针杆孔的深处，拧紧机针固定螺丝 ①。
机针使用 DP × 5-(#11J、#14J)。



安装机针时，请一定关掉电源。

4-3. 上线的穿线方法

**注意**

为了防止突然起动造成人身事故，请关掉电源，确认马达确实停止转动后再进行操作。

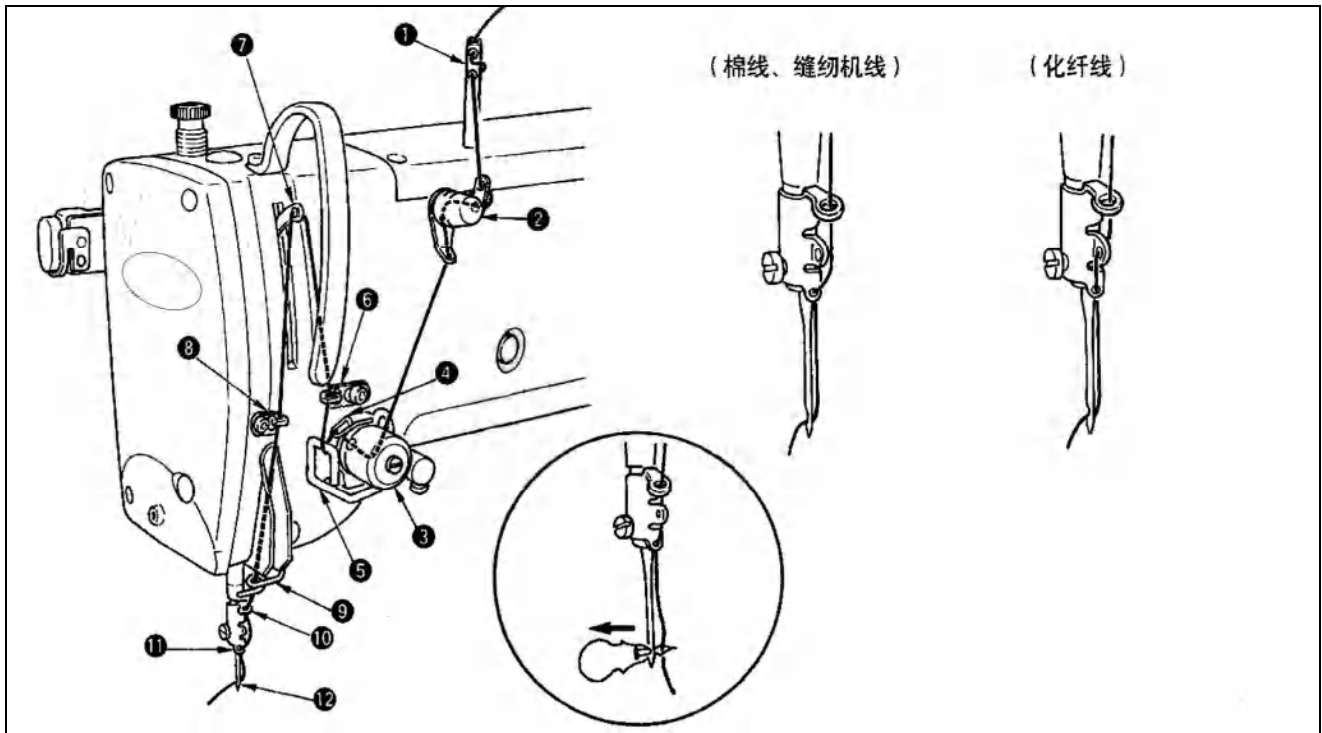

上线如图所示 ① ~ ⑫ 的顺序进行穿线。
把线穿针时，使用附属的穿线器非常方便。
使用机线不同，导线器的穿线方法也不同。

4-4. 梭壳的穿线方法

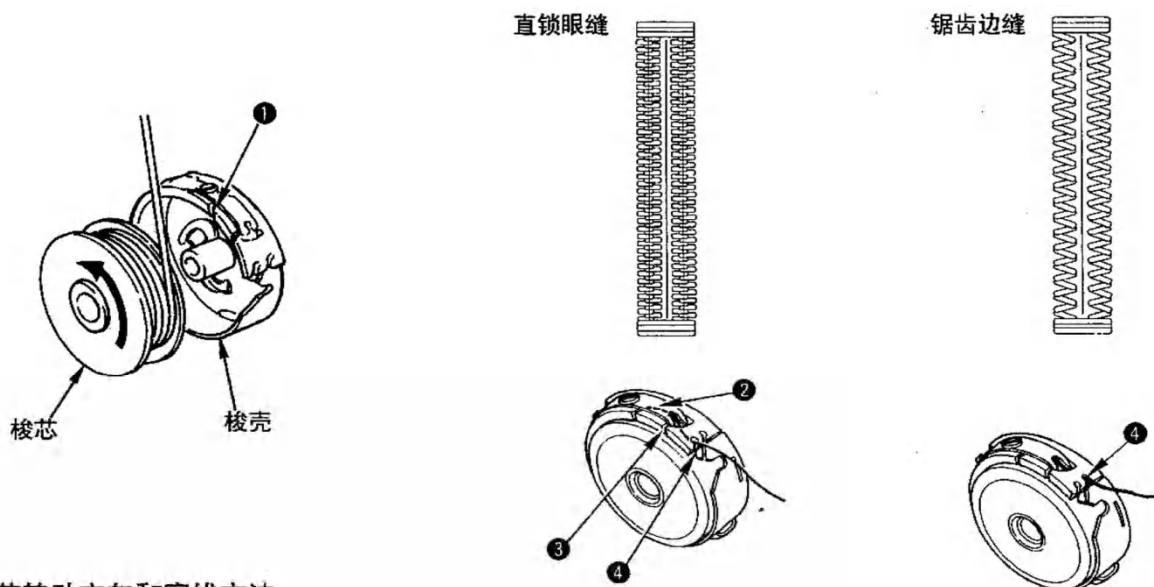

梭芯转动方向和穿线方法

- 1) 请按照箭头所指示的方向把梭芯插进去。
- 2) 请把机线穿过穿线口 ①，然后再从张力弹簧 ② 的下面蹶过去，再次穿过穿线口 ③，从 ④ 把线拉出来。
- 3) 请注意进行直锁眼缝和锯齿边缝时，④ 的穿线方法不同。

4. 缝纫前的准备

4-5. 底线张力的调整

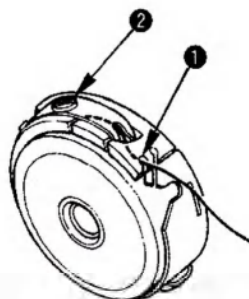

在梭壳穿线口 ① 在上方的位置，把底线向上拉出之后，请按照下列的方法调整底线张力。

直锁眼缝	0.05 ~ 0.15N	手拿从梭壳出来的线头，轻轻地上下摆动时，梭壳就稍稍下降
锯齿边缝	0.15 ~ 0.3N	手拿从梭壳出来的线头，用稍稍强的力量摆动时，梭壳才下降

把线张力螺丝 ② 向右转动，底线张力变强，向左转动，底线张力变弱。

使用化纤缝纫机线时，请把张力稍稍减弱，棉纱线时请稍稍加强。因为本机装有防止空转弹簧，所以装上旋梭之后的线张力请再调强 0.05N 左右。



调整了底线张力之后，请确认存储器开关的上线张力设定。〔参照 P41〕

4-6. 梭壳的安装方法



注意

为了防止突然起动造成人身事故，请关掉电源，确认马达确实停止转动后再进行操作。

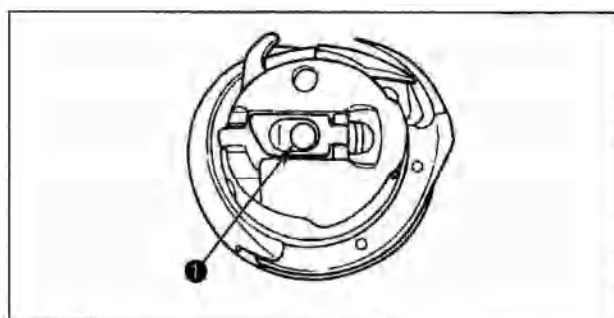

- 1) 拨起梭壳抓手。
- 2) 插入中旋梭轴 ①，关闭抓手。梭壳被按到一定位置会听到喀嗒的响声。



1. 如果梭壳没有在规定的位罝，缝纫后梭心会飞出来，上线绕到旋梭轴上。
2. 因为标准旋梭和干式旋梭的形状不一样，所以不能通用。

4-7. 切刀的安装方法

**注意**

为了防止突然起动造成人身事故，请关掉电源，确认马达确实停止转动后再进行操作。

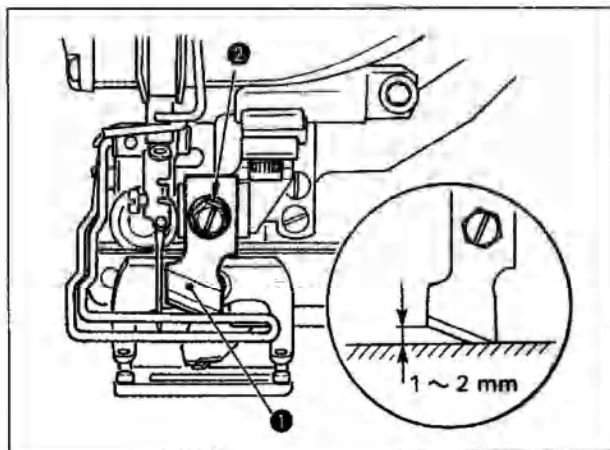

请按如下的步骤更换新的切刀。

- 1) 卸下切刀固定螺丝②之后，就可以把切刀①和垫片一起简单地卸下来。
- 2) 用手按下切刀之后，如图所示把切刀和针板上面的距离调整到1 - 2mm，然后一定套上垫片，并拧紧固定。

英寸 → mm 换算表

切刀尺寸	mm 表示
1/4	6.40
3/8	9.50
7/16	11.10
1/2	12.70
9/16	14.30
5/8	15.90
11/16	17.50
3/4	19.10
13/16	20.60
7/8	22.20
1	25.40
1 1/8	28.60
1 1/4	31.80
1 3/8	34.90
1 1/2	38.10

如果您手中的切布刀是用英寸表示时，可以查看英寸 → mm 换算表用 mm 来设定切布刀的长度（切刀尺寸）。（参照 P28）

5、缝纫机的操作

5-1. 操作盘的开关说明

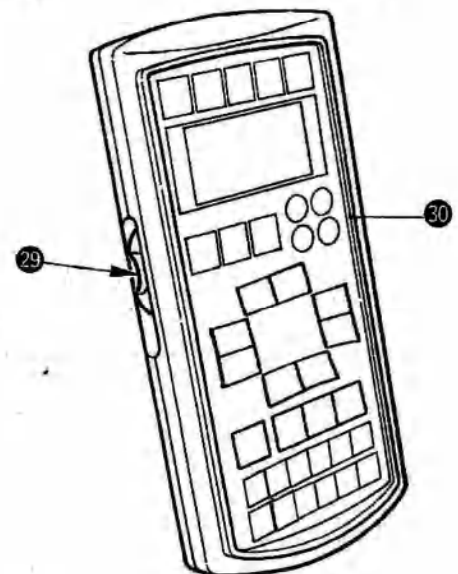
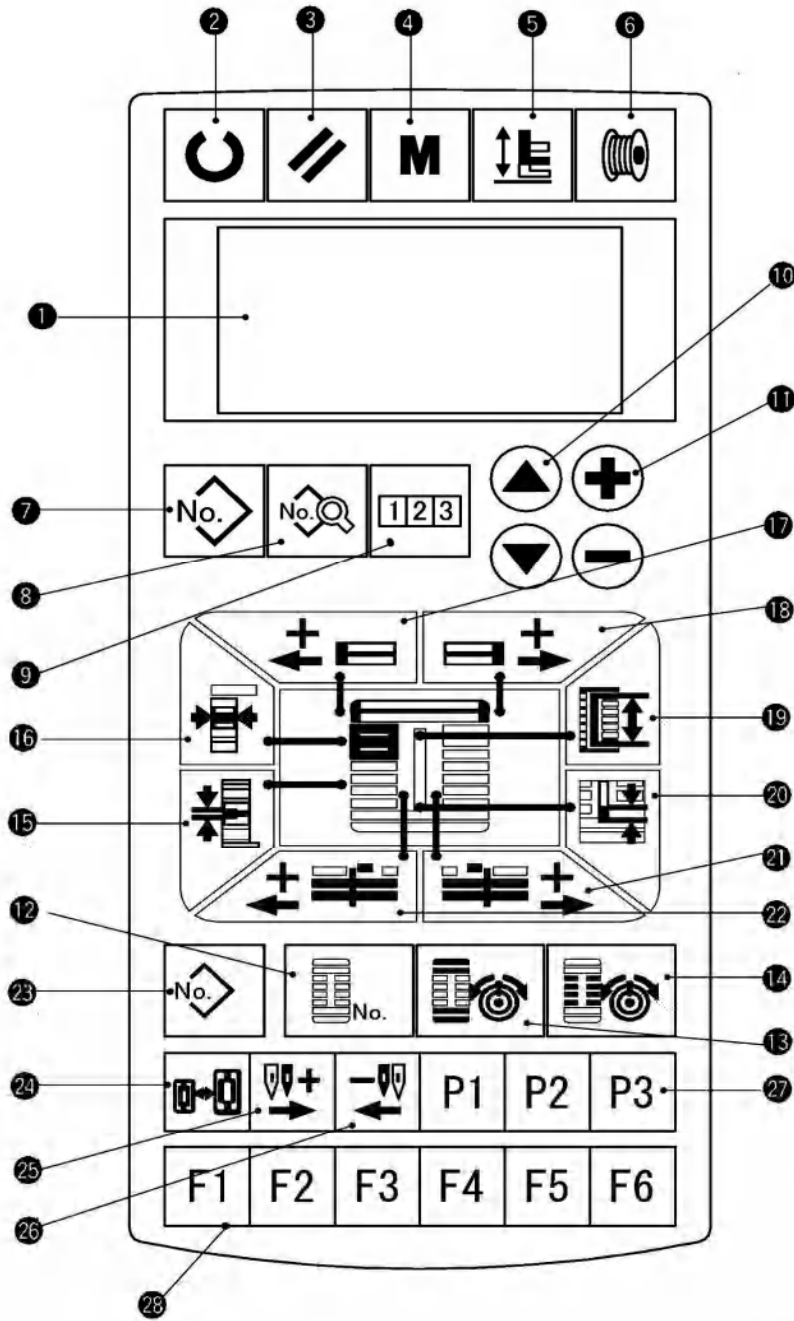

不同的背光的颜色，表示如下 3 种状态。

蓝色：输入模式 可以变更数据。

绿色：缝制模式 这是可以缝制的状态。

黄色：异常状态 表示发生了某种异常。

No.	名称	功能	No.	名称	功能
1	液晶显示部	表示图案 No.、形状等各种数据。	16	包边宽度键 	选择显示包边宽度。
2	准备键 	开始缝制时按。 按键后，顺次变换缝制准备完了状态和数据设定状态。	17	左加固宽度键 	选择显示左加固宽度补偿。
3	复位键 	解除错误、移动到初期位置、计数复位等时按。	18	右加固宽度键 	选择显示右加固宽度补偿。
4	模式键 	变更存储器开关的数据时按。	19	切布长度键 	选择显示切布长度。
5	压脚键 	提升、下降压脚。 上升时，把针杆移动到原点；下降时，把针杆移动到右侧。	20	间隙键 	选择显示间隙。
6	绕线键 	在绕线时按。	21	右切刀槽宽度键 	选择显示右切刀槽宽度补偿。
7	图案 No. 键 	选择显示图案 No.。	22	左切刀槽宽度键 	选择显示左切刀槽宽度补偿。
8	数据键 	选择显示数据。	23	复制键 	复制图案时按。
9	计数键 	选择显示计数。	24	压脚选择键 	选择压脚类型时按。
10	项目选择键 	选择图案 No.、数据 No. 等。	25	前进键 	1 针 1 针前送针。
11	数据变更键 	变更各种数据。	26	后退键 	1 针 1 针倒送针。
12	形状键 	选择显示形状。	27	图案登记键 	这是可以登记图案的快捷键。 可以登记变换到任意的图案设置的快捷图标。设定方法请参照 P36。
13	平行部线张力键 	选择显示平行部线张力。	28	参数登记键 	这是可以登记参数的快捷键。 可以登记变换到显示任意的图案、缝制参数及调整数据的设定。设定方法请参照 P37。
14	加固部线张力键 	选择显示加固部线张力。	29	速度旋钮	往上调速度变快，往下调速度变慢。
15	间隔键 	选择显示平行部间隔。	30	液晶调整旋钮	可以调整液晶显示明暗。

5-2. 缝纫机的基本操作

1) 打开电源开关

首先，请确认被设定的压脚类型 A 和实际安装的压脚类型是否一样。确认和设定方法请参阅 4. 压脚类型的输入。

2) 选择想缝制的图案 No.

打开电源后，现在被选择的图案 No. B 闪亮。想变更时，按选择项目键 ⑩ ▲ ▼ 选择想缝制的 No.。购买时，在 11. 变更缝制数据时里记载的图案 No.1 - 10 均已被登记，因此可以从中选择。（图案没有被登记的号码不显示。）

3) 进入可以缝制状态

按准备键 ②  之后，液晶显示 ① 的背景灯由蓝色变为绿色，成为可以缝制的状态。

4) 开始缝制

把缝制物放到压脚部，踩踏板，缝纫机开始缝制。

购买时，设定为双踏板规格，踏板操作方法可以从 3 种中进行选择。请选择喜欢的操作方法使用。

→ 5-3. 踏板的操作方法

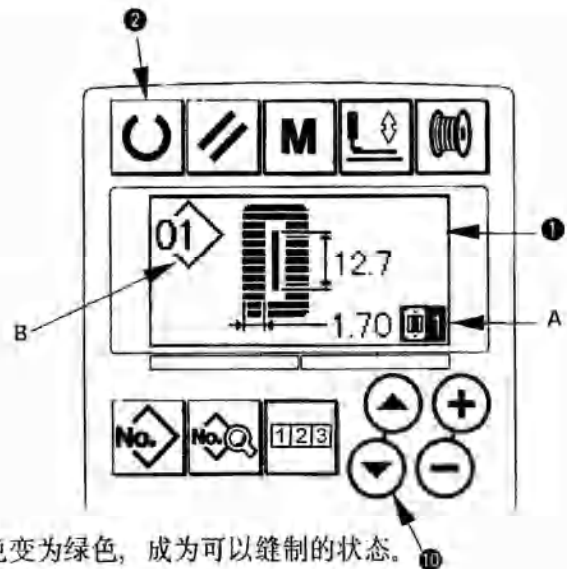

5-3. 踏板的操作方法

本缝纫机，可以从下列 3 类型中选择踏板的操作方法使用。请选择作业效率高的和喜欢的操作方法使用。

(1) 踏板类型的设定方法

1) 叫出踏板类型的设定参数

在输入模式的状态下，3 秒钟以上持续按模式键 ④  之后，存储器开关（2 级）编辑画面 A 被显示出来。如果踏板类型选择参数 **K01** 没有被显示时，请按项目选择键 ⑩ ▲ ▼。

2) 选择踏板类型

如果按数据变更键 ⑪  ，下图那样图案因为被变更，所以请选择喜欢的踏板类型 B。

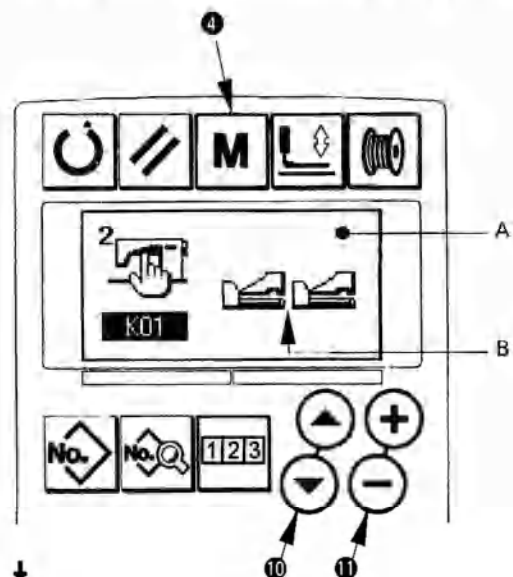

5-4. 输入压脚类型

(1) 压脚类型的设定方法

1) 叫出压脚类型的设定参数

按压脚选择键 ，显示出存储器开关（等级 1）编辑画面 A。

2) 选择压脚类型

按数据变更键  之后，如下图所示图标变更，参考下面的压脚类型一览表设定安装在缝纫机上的压脚类型 B。

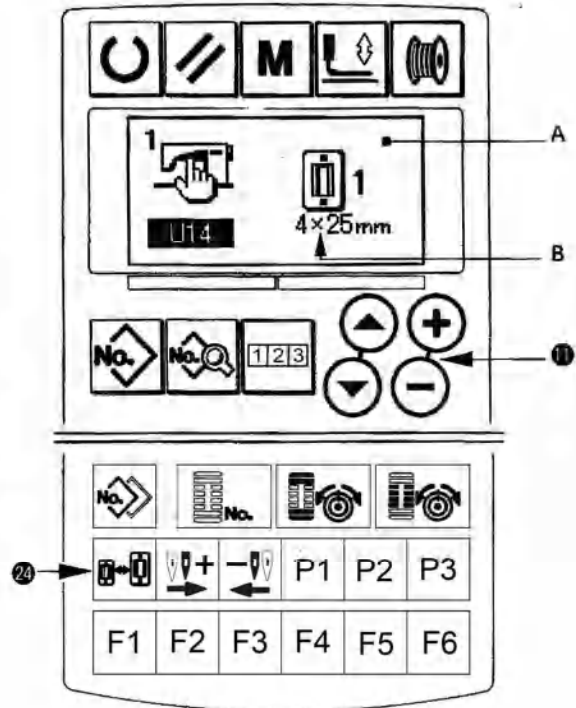
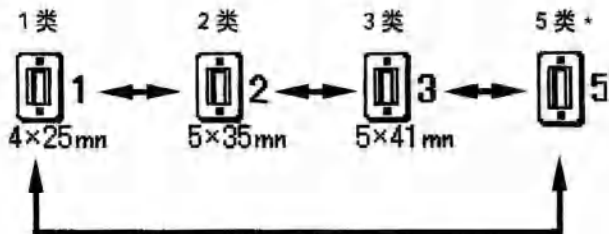

(2) 压脚类型一览表

压脚头的刻印货号应和压脚类型一致。

	类型	压脚货号
 4×25mm	1类	CS0151177  000 *
 5×35mm	2类	CS0151177  000 *
 5×41mm	3类	CS0151177  000 *
	5类*	

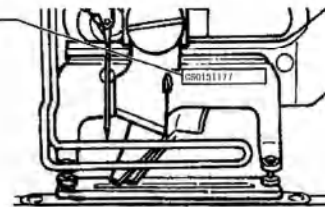

* 使用 1 ~ 3 类以外的压脚头时，请设定为 5 类。

请根据使用的存储器开关（1 级）的 **U15** 压脚尺寸和 **U16** 压脚尺寸长度的压脚进行变更。→ 请参照 5-20. 存储器开关数据的变更方法的内容。

* 5 类摆动宽度 6mm 以上，长度 41mm 以上时，需要更换压脚曲柄、送布板等零部件。

5-5. 选择图案

(1) 从选择画面进行选择



1) 设定为输入模式

液晶显示 ① 的背景照明为蓝色输入模式时，可以变更图案。背景照明为绿色的缝制模式时，请按准备键 ②  变换为输入模式。

2) 叫出图案样选择画面

按图案 No. 键 ⑦ ，显示出图案选择画面 A。现在被选择的图案 No.B 闪亮。

3) 叫出图案样选择画面

按项目选择键 ⑩  ，被登记的图案顺次地被显示。这时请选择想缝制的 No.。

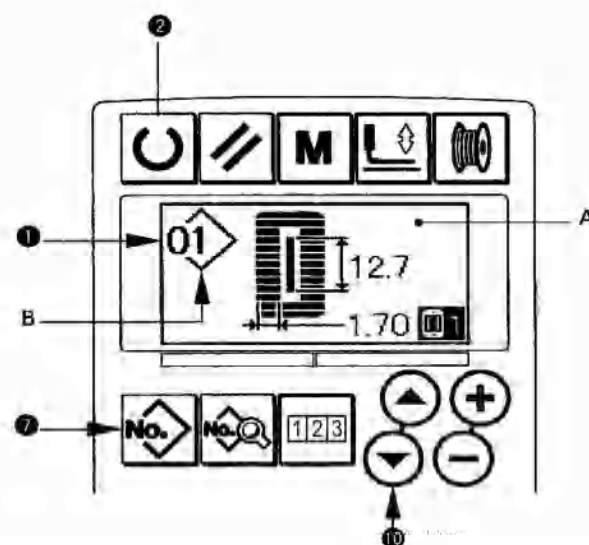

(2) 用登记键选择

在本缝纫机的登记开关里可以登记喜爱的图案 No.。图案登记之后，只要按此开关就可以选择图案。
→ 请参照 3-15. 使用图案登记键的内容。

5-6. 变更上线张力

有关上线张力的数据，可以用缝制模式进行设定，也可以边试缝边变更。

1) 叫出平行部张力设定数据

按平行部张力键 **13** ，显示出缝制数据编辑画面 A。

2) 变更平行部张力

按数据变更键 **11** \oplus \ominus ，增减设立值 B 可以进行变更。

缝制和设定值的关系如下图所示，请参考设定。

3) 叫出加固部张力设定数据

按加固部张力键 **14** ，显示出缝制数据编辑画面 C。

4) 变更加固部张力

按数据变更键 **11** \oplus \ominus ，增减设立值 D 可以进行变更。

缝制效果和设定值的关系如下表所示，因此请参考下表进行设定。

※ 平行部和加固部以外的张力，请参照 5-11. 变更缝制数据和 5-20. 存储器开关数据的变更方法的有关内容。

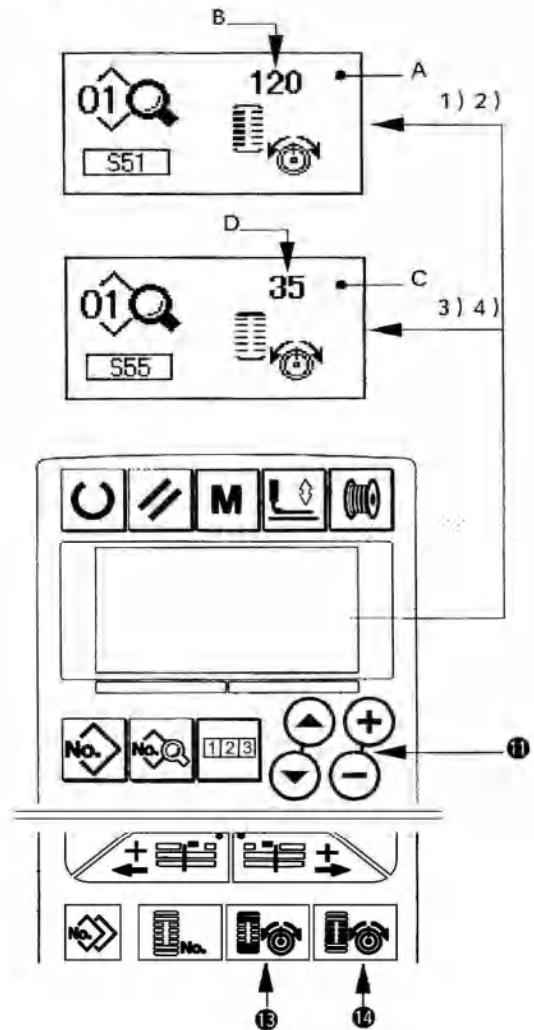

① 平行布张力，② 加固缝张力的设定值

	操作盘设定值			
		\ominus	初期值	\oplus
直锁眼缝	① 平行布张力	降低聚起	120	提高聚起
	② 加固张力	降低张力	35	提高张力
锯齿边缝	① 平行布张力	降低张力	60	提高张力
	② 加固张力	降低张力	60	提高张力

放射圆头形状时，请把加固张力先设定为 120 左右，成为平衡缝迹的张力。

锯齿边缝 直锁眼缝

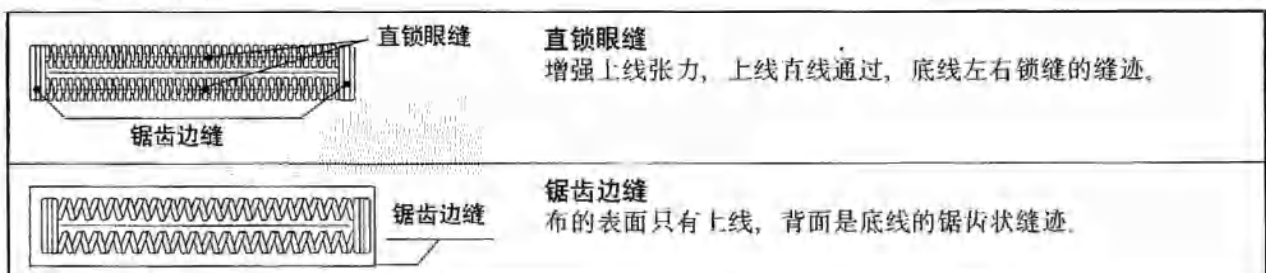

5-7. 修理缝制时

缝制动作中，按停止开关 A 之后，缝纫机中断缝制停机。这时显示错误显示画面 B，通知停止开关被按下。

途中继续进行缝制

缝制动作停止状态



显示错误显示画面 B



1) 解除错误

按复位键 ③ , 解除错误后，显示出步骤动作画面 C。

2) 返回运针

按后退键 ②⑥  后，压脚 1 针 1 针返回，按前进键 ②⑤  之后，变为前进。请把压脚返回到重新缝制位置。

3) 重新开始缝制

踩右侧踏板之后，缝制重新开始。

从最初开始重新缝制

缝制动作停止状态

显示出错误显示画面 B

1) 解除错误

按复位键 ③ , 解除错误之后，显示出步骤动作画面 C。

2) 返回缝制物安放位置

再一次按复位键 ③  之后，返回到缝制物安放位置（开始位置）。

3) 从最初开始重新缝制

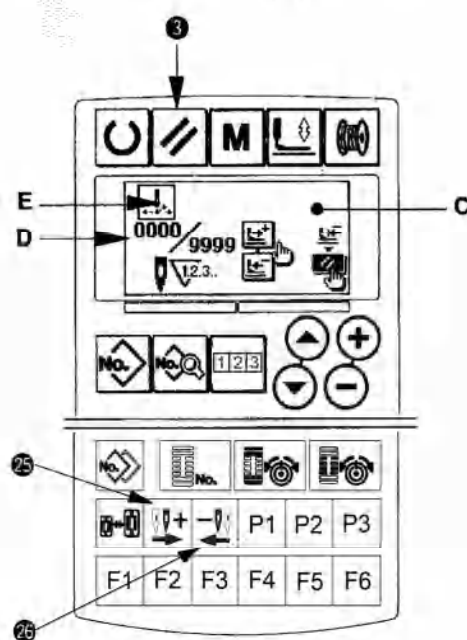
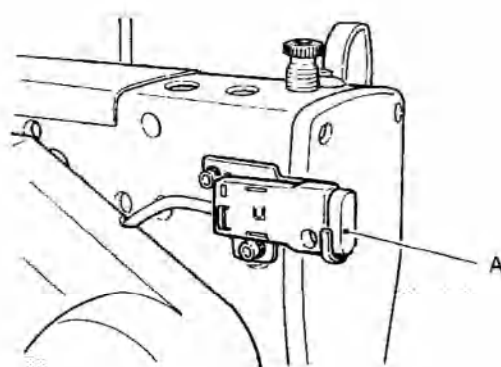

※在 D 部，显示出现在针数 / 总针数。

※在 E 部，显示出缝制指令。

指令的种类有

缝制指令



切线指令



空送指令



切刀指令



5-8. 绕底线

(1) 底线的绕线方法

1) 安装梭芯

把梭芯插到绕线轴上。按图示的顺序穿线，往梭芯上绕线。然后，向箭头符号方向按梭芯导向器①。

2) 设为绕底线模式

在缝制状态或在输入状态，按绕线键⑥之后，进入绕线模式，显示出绕线模式 C。

3) 开始绕线

踩踏右侧踏板之后，缝纫机转动，开始卷绕底线。

4) 停止缝纫机

卷绕完规定量的底线之后，梭线导线器①被解除，请按绕线键⑥或者踩踏右侧踏板让缝纫机停止转动。然后，取下梭芯，用切线固定板④切线。

- 按绕线键⑥之后，缝纫机停止转动，返回到通常模式。

- 踩踏右侧踏板的话，缝纫机在原来的绕线模式停止，如果卷绕数个梭芯时，可以使用这个方法。

(2) 绕线量的调节

调整底线卷线量时，请拧松固定螺丝②，把调节板③移动到 A 方向或 B 方向，然后再拧紧固定螺丝②。

A 方向：变少

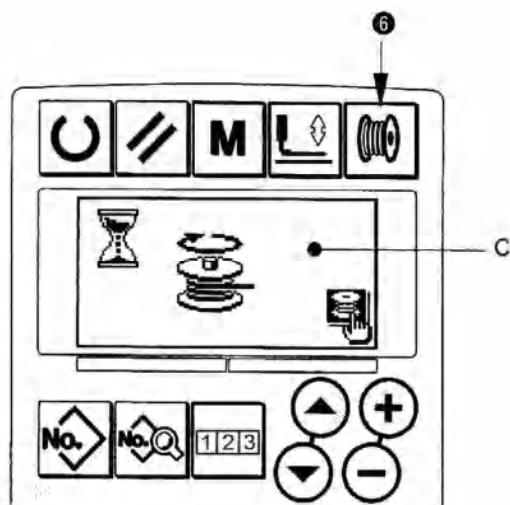
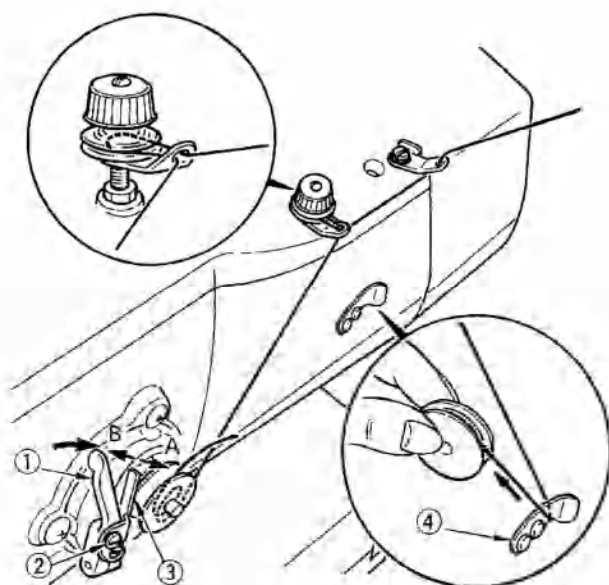

B 方向：变多





5-9. 使用计数器



(1) 计数器值的设定方法

1) 叫出计数器设定画面





在输入模式按计数器键 ⑨  之后，显示出可以设定计数器画面 A。计数器值的设定，只能在输入模式（液晶 ① 的背景照明蓝色）时设定。缝制模式（液晶 ① 的背景照明绿色）时，请按准备键 ②  之后变为输入模式。

2) 计数器类别的选择





按项目选择键 ⑩  ，表示计数器类别的图标 B 闪亮。

按数据变更键 ⑪  ，从下列计数器类别中选择适当的计数器。

3) 计数器设定值的变更

按项目选择键 ⑩  ，计数器设定值 C 闪亮。
按数据变更键 ⑪  ，输入设定值。

4) 计数器现在值的变更

按项目选择键 ⑩  ，计数器现在值 D 闪亮。
按复位键 ③  之后，可以清除计数器途中的值。另外，用数据变更键 ⑪   也可以进行数值编辑。

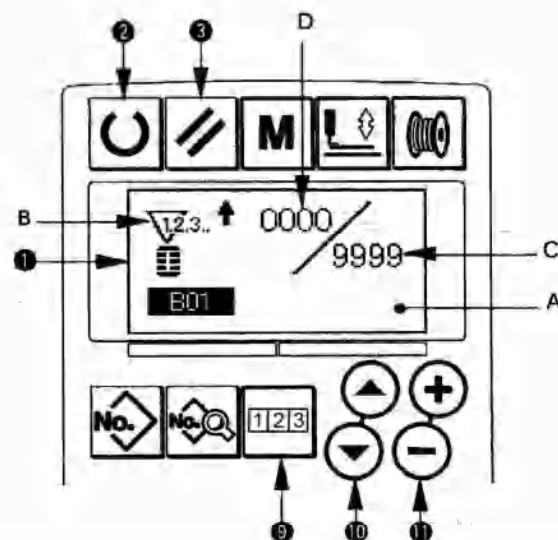



(2) 计数器类别

 ① 缝制加数计数器
每进行 1 形状的缝制之后，现在值数字加 1。
现在值和设定计数器

 ② 缝制减数计数器
每进行 1 形状的缝制之后，现在值数字减 1。
现在值到达 0 之后，显示出减数计数器画面。

 ③ 件数加数计数器
每进行 1 个周期或 1 个连续缝制之后，现在值数字加 1。现在值和设定值相等之后，显示出加数计数器画面。

 ④ 件数减数计数器
每进行 1 个周期或 1 个连续缝制之后，现在值数字减 1。现在值到达 0 之后，显示出减数计数器画面。

 ⑤ 不使用计数器

(3) 计数器类别

缝制作业中如果到达加数条件之后，则显示出加数画面 E。按复位键 ③  之后，复位计数器，返回缝制模式。而且，开始再计数。

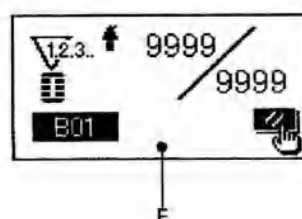

5-10. 使用初期值模式

本缝纫机设有最适的缝制形状（30种形状）的初期值。

→ 请参照 XI，各种形状的初期值数据一览表



新编制缝制数据时，采用复制初期值副本的方法非常便利。

1) 设为输入模式



设为输入模式 ① 的背景照明为蓝色的输入模式时，可以变更图案。背景照明为绿色的缝制模式时，请按准备键 ②  变换为输入模式。

2) 叫出初期值模式

按图案 No. 键 ⑦  之后，显示出图案选择画面 A。

现在被选择的图案 No. B 闪亮，所以按项目选择键 ⑩ ，选择初期值图案 。

3) 选择形状

按形状键 ⑫  之后，形状选择画面 C 被显示，现在被选择的形状 D 闪亮。请选择用数据变更键 ⑪  缝制的形状 D。购买时，可以从 12 种形状中进行选择，但是如果升级了形状选择等级（K04），则最多可以从 30 种形状中进行选择。

→ 请参照 5-20. 存储器开关数据的变更方法的内容。

4) 进行试缝

按准备键 ② ，设定为缝制模式（液晶显示 ① 的背景照明为绿色）之后，变为缝制模式，可以缝制选择的形状。

※ 请注意，初期值图案仅可以编辑上线张力数据，如果变更形状，再次叫出新的图案的话，必须返回初期值。

5) 复制初期值图案

把上述步骤中选择、确认的图案复制到通常图案里。复制方法 → 请参照 5-14. 复制缝制图案的内容。

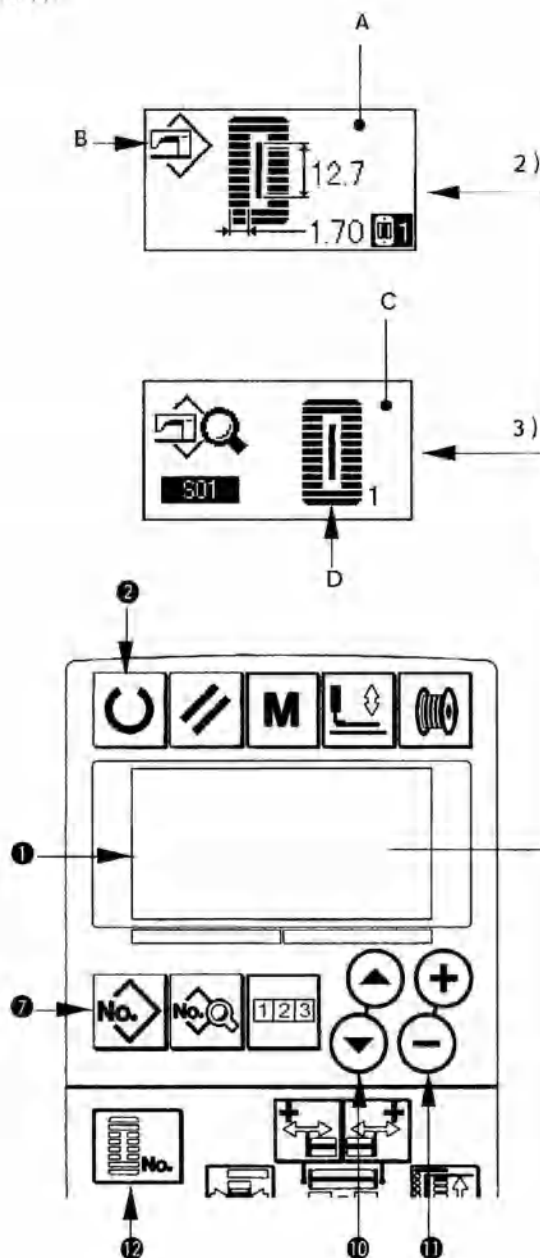

5-11. 变更缝制数据



(1) 购买时的初期缝制数据

购买时，已经登记了1～10的图案，该缝制数据仅切布长度的各种不同的角型形状的初期值被输入。
→角型形状初期值请参照XI. 各种形状的初期值数据一览表

图案 No.	切布长度  S02
1	6.4 mm (1/4 英寸)
2	9.5 mm (3/8 英寸)
3	11.1 mm (7/16 英寸)
4	12.7 mm (1/2 英寸)
5	14.3 mm (9/16 英寸)
6	15.9 mm (5/8 英寸)
7	17.5 mm (11/16 英寸)
8	19.1 mm (3/4 英寸)
9	22.2 mm (7/8 英寸)
10	25.4 mm (1 英寸)

(2) 缝制数据的变更方法

1) 设定为输入模式

用液晶显示  背景照明青色输入方法，可以变更缝制数据。背景照明绿色的缝制方法的场合，请按准备键  变换输入方法。

2) 叫出缝制数据编辑画面

按数据键  之后，显示出现在被选择的图案 NO. 的缝制数据编辑画面 A。

3) 选择变更的缝制数据

按项目选择键 ，选择想变更的数据项目。请注意有的形状不使用的数据项目和没有设定功能的数据项目均不能被显示。

→ 请参照 5-12. 缝制数据编辑有/无的设定方法的内容。

4) 变更数据

缝制数据中，有变更数值的数据项目和选择图标的数据项目。

变更数值的数据项目有  那样的 No.，可以用数据变更键    增减设定值进行变更。选择图标的数据项目有  那样的 No.，可以用数据变更键    选择图标。

→ 缝制数据的详细内容，请参照 5-13. 缝制数据一览表。

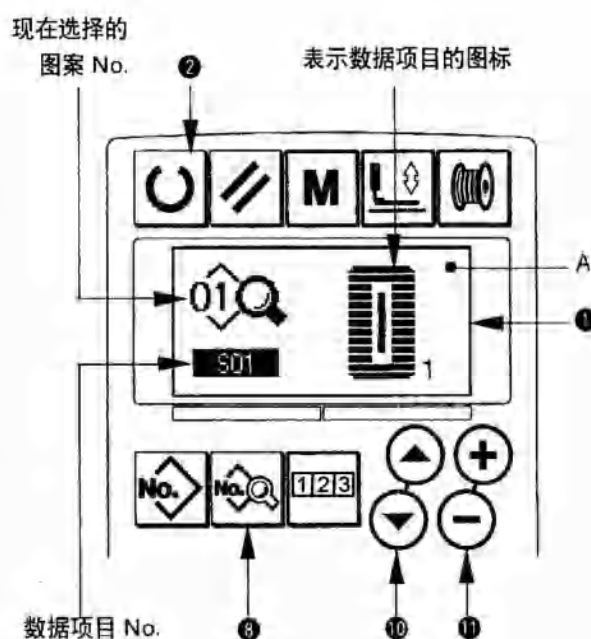

5-12. 缝制数据编辑有/无的设定方法

购买时，本缝纫机把使用频率低的缝制数据项目设定为不能编辑。如果缝制物需要进行更详细的设定，请将该缝制数据项目设定为可以编辑状态。

- * 缝制数据的编辑有/无的设定。当把 S52 右平行部张力设定为无编辑后，则用 S51 左平行部张力进行缝制。如果把 S56 第 2 加固张力设定为无编辑后，则用 S55 第 1 加固张力进行缝制。设定为不编辑其他的缝制数据项目时，则为初期值数据。



1) 设定为输入模式

液晶显示 ① 的背景照明为蓝色输入模式时，可以设定。背景照明为绿色的缝制模式时，请按准备键 ②  变换为输入模式。



2) 叫出缝制数据有/无编辑的变换画面

按数据键 ③  3 秒钟之后，显示出数据有/无编辑的变换画面 A、B。

3) 选择想变换的缝制数据

按项目选择键 ⑩  ，选择想变换的缝制数据项目 C。此时，仅可以选择可以变换的项目。



4) 变换有/无编辑

按数据变更键 ⑪   之后，选择的缝制数据图标显示 C 可以反覆反转/不反转。

反转显示：可编辑 不反转显示：不可编辑

返回步骤 3，可以转换复数的缝制数据项目。

5) 保存设定的数据

按准备键 ②  之后，变为保存状态，2 秒钟后返回原来的画面。按复位键 ⑧  之后，不保存返回原来的画面。

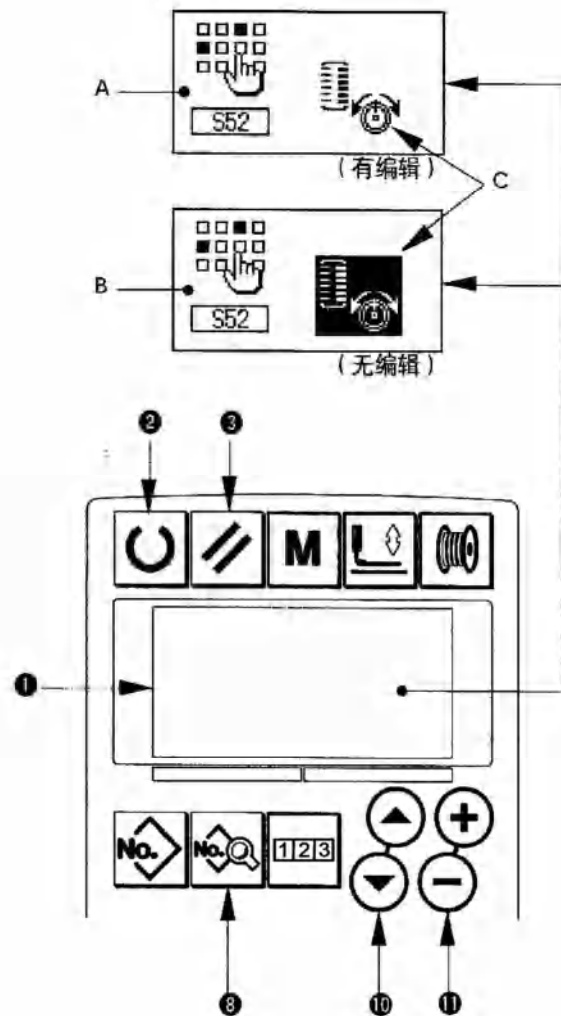

5-13. 缝制数一览表

- ☆ 缝制数据为图案 1 ~ 99 的 99 个图案的可以输入的数据，可按每种图案进行输入。
 购买时，为不能选择设定有 / 无编辑数据的状态。使用时，请根据需要变换为有编辑的状态后再使用。→ 请参照 5-12. 缝制数据编辑有 / 无的设定方法。

No.	项目	设定范围	编辑单位	备考
S01	缝制形状 可以从缝纫机所具有的 30 种缝制形状中选择形状。  参照 II-3. 标准缝制形状一览表 ※ 购入时，只能选择标准的 12 种缝制形状。 增加形状种类时，请进行存储器开关数据 K04 缝制形状等级的设定。→ 请参照 21. 存储器开关数据一览表。	1 ~ 30	1	—
S02	切布长度 设定切布刀切断缝制品的长度。 但是，条形卷褶形状（S01 的形状 NO.27、28、29、30）时，只能设定缝制长度。 将存储器开关数据的 U19 切布刀数次动作功能设定为有效之后，就可以按照 U18 切布刀尺寸设定的切刀尺寸，让切刀数次动作，切断缝制品。 → 请参照 21. 存储器开关数据一览表。	3.0 ~ 120.0	0.1mm	—
S03	右切刀槽宽度 设定切布刀和右平行部的间隙。	-2.00 ~ 2.00	0.05mm	—
S04	左切刀槽宽度 设定切布刀和左平行部的间隙。	-2.00 ~ 2.00	0.05mm	—
S05	左包边宽度 设定左平行部的包边宽度。	0.10 ~ 5.00	0.05mm	—
S06	左右形状比率 设定以切刀位置为中心的右侧形状的扩大缩小率。	50 ~ 150	1%	—
S07	平行部间隔 设定左右平行部的缝制间隔。	0.200 ~ 2.500	0.025mm	—
S08	第 2 加固部长度 设定面前的加固部长度。 角型下  直线加固下  锥形下 	0.2 ~ 5.0	0.1mm	—
S09	第 1 加固部长度 设定里侧加固部的长度。 角型上 	0.2 ~ 5.0	0.1mm	—

* 1: 不同的形状有不同的显示。

* 2: 设定为有编辑之后被显示。请参照 5-12. 缝制数据编辑有 / 无的设定方法。







* 3: 选择功能之后，被显示。

5. 缝纫机的操作

No.	项目	设定范围	编辑单位	备考
S10	加固部右宽度修正 调整加固部的右侧外形和包缝部。 第1加固、第2加固均被修正。 角型上  角型下  直线加固下 	-1.00 ~ 1.00	0.05mm	—
S11	加固部左宽度修正 调整加固部的左侧外形和包缝部。 角型上  角型下  直线加固下 	-1.00 ~ 1.00	0.05mm	—
S12	锥形加固部左对称 设定形成锥形加固形状的加固部的长度。	0.00 ~ 3.00	0.05mm	* 1
S13	锥形加固部右对称 设定形成锥形加固形状的加固部的长度。	0.00 ~ 3.00	0.05mm	* 1
S14	圆头扣眼形状长度 设定从圆头扣眼形状的圆头扣眼中心到上侧的长度。	1.0 ~ 10.0	0.1mm	* 1
S15	圆头扣眼形状针数 设定圆头扣眼形状的上部90度中的缝制条数。	1 ~ 8	1	* 1
S16	圆头扣眼宽度 设定圆头扣眼形状的内侧横尺寸。 实际的落针处为加算上 S04 切刀槽左宽度的尺寸。	1.0 ~ 10.0	0.1mm	* 1
S17	圆头扣眼长度 设定圆头扣眼形状的内侧竖尺寸。	1.0 ~ 10.0	0.1mm	* 1
S18	圆型形状长度 设定圆型形状的中心到上侧的长度 圆型上  放射上  半月上  圆型下  放射下  半月下 	1.0 ~ 5.0	0.1mm	* 1
S19	放射形状针数 设定放射形状的上部90度中的缝制条数。	1 ~ 8	1	* 1
S20	放射形状加固 设定有/无放射形状的加固缝。  : 有  : 无	—	—	* 1, * 2
S21	加固部间隔 设定加固部的缝制间隔。 角型上  圆型上  半月上  角型下  圆型下  半月下  直线加固  锥形下 	0.200 ~ 2.500	0.025mm	—



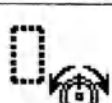

NO.	项目	设定范围	编辑单位	备考
S22	第 1 间隙 设定第 1 加固和切刀槽间的间隙。 适用于全形状。 	0.0 ~ 4.0	0.1mm	—
S23	第 2 间隙 设定第 2 加固和切刀槽间的间隙。 适用于全形状。 	0.0 ~ 4.0	0.1mm	—
S31	单 / 双重 选择单缝、双重缝。  X1 : 单缝  X2 : 双重缝	—	—	—
S32	选择交叉双重缝。 设定双重缝时, 请选择是重叠缝制平行部的落针还是进行交叉缝制。  : 重叠缝  : 交叉缝	—	—	+ 3
S33	修正双重缝宽度 设定双重缝时, 设定第 1 循环的包缝宽度缩小量。 	0.0 ~ 2.0	0.1mm	+ 3
S34	下缝次数 设定下缝的次数。  : 无下缝  : 有下缝 (设定次数)	0 ~ 9	1 次	—
S35	下缝间隔 设定进行下缝时的缝制间隔。 	1.0 ~ 5.0	0.1mm	+ 3
S36	下缝卷入长度 设定进行下缝时的上线卷入缝制长度。 	2.0 ~ 20.0	0.1mm	+ 3
S37	下缝卷入间隔 设定进行下缝时的上线卷入缝制间隔。 	0.2 ~ 5.0	0.1mm	+ 3
S38	下缝卷入宽度 设定进行下缝时的上线卷入缝制宽度。 	0.0 ~ 4.0	0.1mm	+ 3
S39	下缝落针前后修正 进行 2 循环以上的下缝时, 设定落针处的前后移动量。 	0.0 ~ 2.5	0.1mm	+ 2, + 3
S40	下缝落针左右修正 进行 2 循环以上的下缝时, 设定落针处的左右移动量。 	0.0 ~ 1.0	0.1mm	+ 3
S41	下缝左侧位置修正 设定把下缝的缝制基准位置从左包缝的中心向左的移动量。 	-2.0 ~ 2.0	0.1mm	+ 2, + 3
S42	下缝右侧位置修正 设定把下缝的缝制基准位置从右包缝的中心向左的移动量。 	-2.0 ~ 2.0	0.1mm	+ 2, + 3

5. 缝纫机的操作

NO.	项目	设定范围	编辑单位	备考
S44	设定下缝速度 设定下缝的速度。 	400 ~ 4200	100rpm	* 3
S45	缝合功能 在进行缝合的最初时进行选择。  无缝合  有缝合 选择了有缝合时 按照 缝合 → 下缝 → 通常缝制 的顺序进行缝制。	—	—	—
S46	缝合宽度 设定进行缝合时的缝制宽度。 	1.0 ~ 10.0	0.1mm	* 2, * 3
S47	缝合间隔 设定进行缝合时的缝制间隔。 	0.2 ~ 5.0	0.1mm	* 2, * 3
S51	左平行部张力 设定左平行部的上线张力。 	0 ~ 200	1	—
S52	右平行部张力 设定右平行部的上线张力。 	0 ~ 200	1	* 2
S53	左平行部张力 (双重缝的第 1 循环) 双重缝时, 设定第 1 循环的左平行部上线张力。 	0 ~ 200	1	* 2, * 3
S54	右平行部张力 (双重缝的第 1 循环) 双重缝时, 设定第 1 循环的左平行部上线张力。 	0 ~ 200	1	* 2, * 3
S55	第 1 加固部张力 设定第 1 加固部的上线张力。 	0 ~ 200	1	—
S56	第 2 加固部张力 设定第 2 加固部的上线张力。 	0 ~ 200	1	* 2
S57	缝制开始上线张力的设定 设定缝制开始加固缝的上线张力。 	0 ~ 200	1	—
S58	下缝上线张力的设定 设定下缝的上线张力。 	0 ~ 200	1	* 3
S59	第 1 加固缝开始, 调整 ACT 同步时间 调整第 1 加固部的上线张力输出开始的同步时间。 	-5 ~ 5	1 针	* 2

NO.	项目		设定范围	编辑单位	备考
S60	右包缝开始, 调整 ACT 同步时间 调整右包缝部的上线张力输出开始的同步时间。		-5 ~ 5	1 针	+ 2
S61	第 2 加固开始, ACT 同步时间 调整第 2 加固部的上线张力输出开始的同步时间。		-5 ~ 5	1 针	+ 2
S62	缝制开始加固缝针数 设定缝制开始加固缝的针数。		0 ~ 8	1 针	—
S63	缝制开始加固缝间隔 设定缝制开始加固缝的间隔。		0.00 ~ 0.70	0.05mm	+ 2
S64	缝制开始的加固缝宽度 设定缝制开始的加固缝宽度。		0.0 ~ 3.0	0.1mm	—
S65	缝制开始加固缝的竖向修正 设定缝制开始加固缝的竖方向开始位置。		0.0 ~ 5.0	0.1mm	+ 2
S66	缝制开始加固缝的横向修正 设定缝制开始加固缝的横方向开始位置。		0.0 ~ 2.0	0.1mm	+ 2
S67	缝制结束加固缝宽度 设定缝制结束加固缝的宽度。		0.1 ~ 1.5	0.1mm	—
S68	缝制结束加固缝针数 设定缝制结束加固缝的针数。		0 ~ 8	1 针	—
S69	缝制结束加固缝竖向修正 设定缝制结束加固缝的竖方向开始位置。		0.0 ~ 5.0	0.1mm	+ 2
S70	缝制结束加固缝横向修正 设定缝制结束加固缝的横方向开始位置。		0.0 ~ 2.0	0.1mm	+ 2
S81	切刀动作 设定通常的切布刀动作有 / 无。  : 通常切刀动作 OFF  : 通常切刀动作 ON		—	—	—
S83	双重缝的第 1 循环切刀 双重缝时, 设定第 1 循环的切布刀有 / 无动作。  : 通常切刀动作 OFF  : 通常切刀动作 ON		—	—	+ 2, + 3
S84	最高速度限制 设定缝纫机的最高转速。 数据编辑的最大值为存储器开关数据 K07 最大转速限制速度的设定的转速。— 请参照 21. 存储器开关数据一览表。 		400 ~ 4200	100rpm	—

5. 缝纫机的操作

NO.	项目	设定范围	编辑单位	备考
S86	前进间隔 设定条形衣褶形状 (S01 的形状 NO.27、28、29、30) 前进侧的缝制间隔。 	0.200 ~ 2.500	0.025mm	—
S87	前进宽度 设定条形衣褶形状 (S01 的形状 NO.27、28、29、30) 前进侧的缝制宽度。 	0.1 ~ 3.0	0.05mm	—
S88	返回间隔 设定条形衣褶形状 (S01 的形状 NO.27、28、29、30) 返回侧的缝制间隔。 	0.200 ~ 2.500	0.025mm	—
S89	返回宽度 设定条形衣褶形状 (S01 的形状 NO.27、28、29、30) 返回侧的缝制宽度。 	0.1 ~ 3.0	0.05mm	—

5-14. 复制缝制图案

可以把已登记的图案 NO. 的数据复制到没有使用的 NO.。因为图案设定为禁止重写复制，所以需要重写时，请先把图案消去后再进行复制。

1) 设定为输入模式

液晶显示 ❶ 的背景照明为青色的输入模式时，可以复制。背景照明为绿色的缝制模式时，请按准备键 ❷  变换为输入模式。



2) 选择要复制的原图案 NO.

选择要复制的原图案 NO.。
在图案选择画面，选择复制的原图案 NO.。
→ 请参照 5. 选择图案的内容。
编制新图案数据时，复制初期值图案的话使用起来非常便利。
→ 请参照 10. 使用初期值模式的内容。

3) 叫出复制画面

按复制键 ❸  之后，显示出复制画面 A。

4) 选择复制位置的图案 NO.

没有使用的图案 No.B 闪亮显示，所以按数据变更键 ❹  ，选择想复制的 No.。
如果想消去图案时，请选择垃圾箱 。

5) 开始复制

按准备键 ❷  之后开始复制，复制 2 秒钟后，在编制图案 No. 被选择的状态，返回输入画面。

按复位键 ❸ ，不复制返回原来的画面。

※ 循环数据、连续缝制数据也可以用同样的方法进行复制。

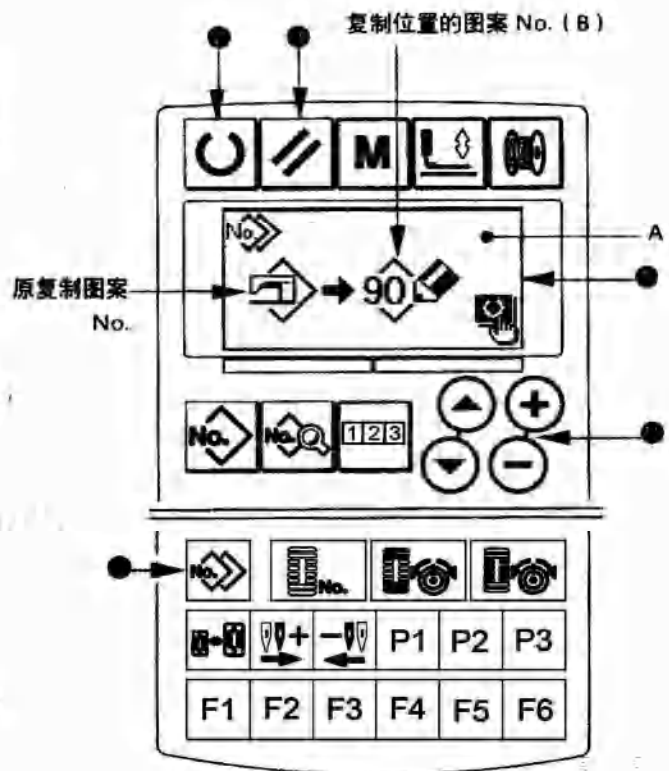

5-15. 使用图案登记键



可以频繁使用的图案 NO. 登记到图案登记键。
用输入模式，只要按图案登记键就可以选择被登记的图案。

(1) 登记方法



1) 设定为输入模式

液晶显示 ① 的背景照明为青色输入模式时方，
可以登记图案。背景照明为绿色的缝制模式时，
请按准备键 ②  变换为输入模式。

2) 叫出图案登记画面

按想登记图案的 No. 的键 (P1 至 P3) ⑦  至
 3 秒钟之后，显示出图案登记画面 A。

3) 选择图案 No.

现在可以使用的图案 NO. B 闪亮显示，所以按项
目选择键 ⑩  ，选择想登记的图案 No.。
选择了垃圾箱  之后，登记可以解除。

4) 开始登记

按准备键 ②  之后开始登记，2 秒后返回输
入画面。

按复位键 ③  之后，不登记返回原来的画面。

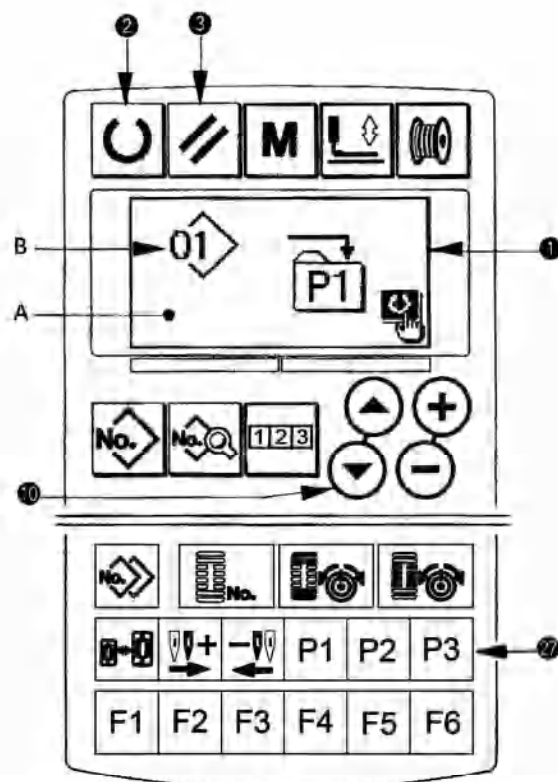

(2) 购买时的登记状态

登记键	登记图案 NO.
P1	图案 NO.1
P2	图案 NO.2
P3	图案 NO.3

5-16. 使用参数登记键时

把可以频繁使用的参数登记到参数登记键进行使用。
用输入模式，只要按参数登记键就可以选择被登记的参数。
另外，此键不仅可以设定参数，还可以登记图案 No.，因此可以使用与 5-15. 使用图案登记键同样的
方法进行登记。

(1) 登记方法

1) 设定为输入模式

液晶显示 ① 的背景照明为蓝色的输入模式时，
可以登记参数。背景照明为绿色的缝制模式时，
请按准备键 ②  变换为输入模式。

5. 缝纫机的操作

2) 叫出参数登记画面

按想登记参数的键 (F1 至 F6) ⑳ 至 ㉑ 3 秒钟之后, 显示出参数登记画面 A。

3) 选择参数

可以登记的登记的项目 B 在键上显示, 所以按项目选择键 ㉒ ㉓ ㉔, 选择想登记的项目。可以登记的项目是缝制数据和存储器开关 (等级 1) 的参数和图案 No.。

另外, 选择垃圾箱 ㉕ 可以解除登记。

4) 开始登记

按准备键 ㉖ U 之后, 开始登记, 2 秒钟后返回输入画面。

按复位键 ㉗ 之后, 不登记返回原来画面。

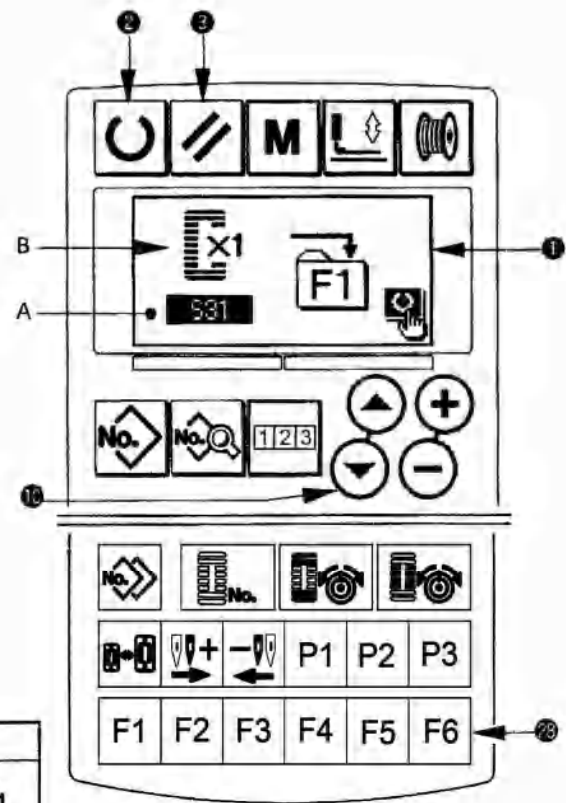

(2) 购买时的登记状态

登记键	登记参数	
F1	单重缝 / 双重缝的变换	
F2	下缝 OFF / 次数	
F3	设定下缝上线张力	
F4	切布刀复数次动作 无效 / 有效	
F5	切布刀尺寸	
F6	设定开始缝上线张力	

5-17. 进行连续缝制时

本缝纫机, 可以不提升压脚, 连续缝制复数图案。

在 1 循环中最多可以自动地缝制 6 种形状。

另外, 最多还可以登记 20 个数据。

需要时, 请复制之后使用。→ 请参照 5-14. 复制缝制图案的内容。

• 有的设定条件, 需要更换购买时安装的零件。

(1) 连续缝制数据的选择

1) 设定为输入模式

液晶显示 ① 的背景照明为蓝色的输入模式时，可以选择连续缝制数据。背景照明为绿色的缝制模式时，请按准备键 ②  变换为输入模式。

2) 叫出图案选择画面

按图案 No. 键 ⑦  之后，显示出图案选择画面 A。现在被选择的图案 No. B 闪亮显示。

3) 选择连续缝制数据

按项目选择键 ⑩  之后，被登记的图案按顺序变换显示，最后登记图案 No. 之后显示被登记的循环数据 No.，连续缝制 No.。在这里请选择想缝制的连续缝制数据 No.。

4) 进行缝制

在连续缝制数据被选择的状态，按准备键 ②  之后，液晶显示 ① 的背景照明变为绿色成为可以缝制的状态。

购买时仅登记了连结数据 No.，而缝制图案没有被输入，所以不能成为可以缝制的状态。请参照下页 (2) 连续缝制数据的编辑方法进行以上的输入。

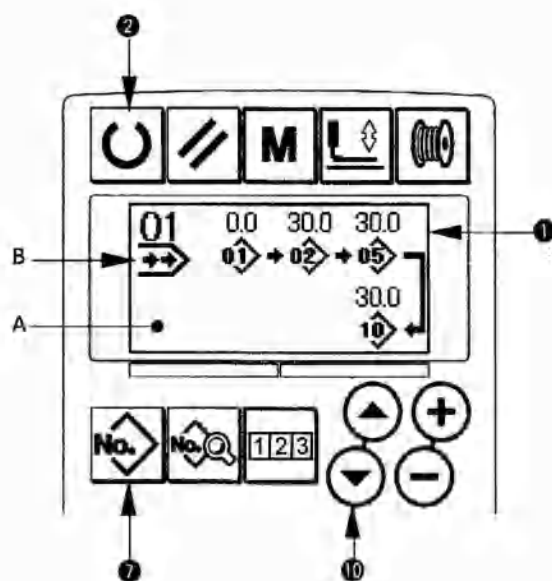



(2) 连续缝制数据的编辑方法

1) 设定为输入模式

液晶显示 ① 的背景照明为蓝色的输入模式时，可以输入连续缝制数据。背景照明为绿色的缝制模式时，请按准备键 ②  变换为输入模式。

2) 叫出编辑的连续缝制数据 NO.

按图案 No. 键 ⑦ ，叫出图案选择画面之后，现在被选择的图案 No. B 闪亮显示。按项目选择键 ⑩  之后，被登记的图案顺次变换显示，最后的登记的图案 No. 之后显示被登记的循环数据 No.，连续缝制 NO.。在这里请选择想缝制的连续缝制数据 NO.。

3) 把连续缝制数据设定为编辑状态

按数据键 ⑧  之后，显示出连续缝制数据编辑显示 C，最初缝制的图案 No. D 闪亮显示。在此状态下可以编辑数据。

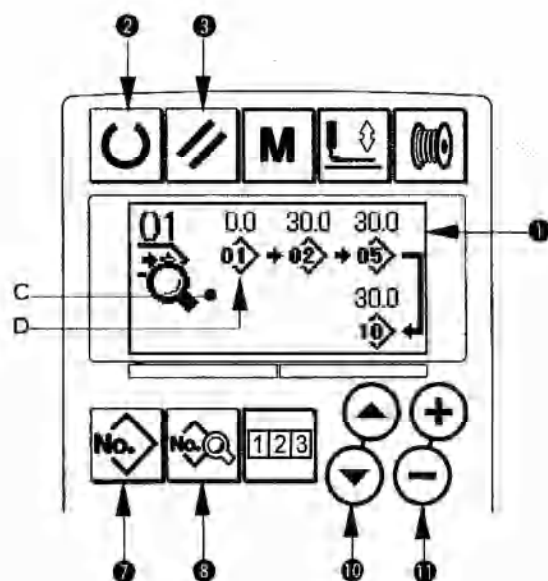

5. 缝纫机的操作

4) 选择编辑要点

按项目选择键 ⑩ (▲) (▼) 之后, 按图案 NO. → 空送量 → 图案 NO. → 空送量的顺次编辑要点移动显示。
进入到数据的最后编辑要点之后, 显示出追加指示图标 。

5) 变更选择的编辑要点的数值

按数据变更键 ⑪ (+) (-) 之后, 可以变更编辑要点的数值。

编辑要点为图案 No. 时

被登记的图案 No. 被显示成为可以选择的状态。

编辑要点为空送时

在 ±120mm 的范围内可以编辑数值。

另外, 按复位键 ⑬ (↖) 之后, 可以消除编辑要点的图案数据。

请重复步骤 4, 步骤 5, 编辑数据。

※ 以上输入完了, 进行连续缝制时, 所有的数据应在压脚尺寸范围内。

因为超过的话, 将显示范围错误, 所以请一定正确地输入压脚尺寸。

→ 请参照 4. 输入压脚类型的内容。

5-18. 进行循环缝制时

本缝纫机可以顺次地缝制复数的循环缝制图案数据。

最大可以输入 15 种图案, 请在缝制物上有复数不一样的扣眼时使用。

另外, 最多还可以登记 20 个数据。

需要时, 请拷贝之后使用。→ 请参照 5-14. 复制缝制图案的内容。

(1) 循环数据的选择

1) 设定为输入模式

液晶显示 ① 背景照明为蓝色输入模式时, 可以选择循环缝数据。背景照明为绿色的缝制模式时, 请按准备键 ② (U) 变更为输入模式。

2) 叫出编辑的循环缝数据 No.

按图案 NO. 键 ⑦ (No.) 之后, 显示出图案选择画面 A。现在被选择的图案 No. B 闪亮显示。

3) 选择循环缝制数据

按项目选择键 ⑩ (▲) (▼) 之后, 被登记的图案顺序地变更显示, 最后登记图案 No. 后, 显示被登记的循环数据 No.、连续缝数据 No.。这时, 请选择想缝制的循环数据 No.。

4) 进行缝制

在循环数据被选择的状态, 按准备键 ② (U) 之后, 液晶显示 ① 的背景照明变为绿色, 成为可以缝制的状态。

购买时仅登记了循环数据 No.1, 没有输入缝制图案, 不能成为缝制状态。因此, 请参照下页 2) 循环数据的编辑方法进行输入。

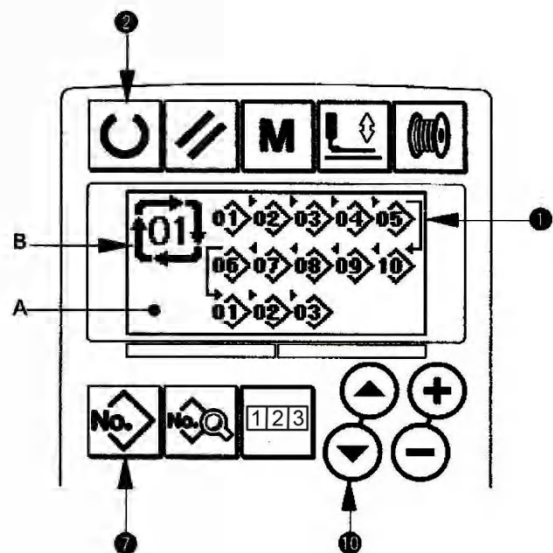



(2) 循环缝数据的编辑方法

1) 设定为输入模式

液晶显示 ① 的背景照明为蓝色的输入模式时，可以输入循环缝数据。背景照明为绿色的缝制模式时，请按准备键 ②  变换为输入模式。



2) 叫出编辑循环缝数据 No.

按图案 No. 键 ⑦ ，叫出图案样选择画面之后，现在被选择的图案 No. B 闪亮显示。按项目选择键 ⑩  之后，被登记的图案顺次地变换显示。最后的图案 No. 以后，显示被登记的循环缝数据 No.、连续缝数据 No.。这里请选择想缝制的循环缝 No.。

3) 把循环缝数据设定为编辑状态

按数据键 ⑧  之后，变为循环缝数据编辑中显示 C，最初缝制的图案 No. D 闪亮显示。此状态可以编辑数据。

4) 选择编辑要点

按项目选择键 ⑩  之后，编辑要点顺次移动闪亮。论据最后进入编辑要点之后，显示出追加指示图标 。

5) 变更选择的编辑要点的的数据

按数据变更键 ⑪  之后，可以变更编辑要点的的数据。被登记的图案 No. 被显示出来，可以进行选择。

另外，按复位键 ③  之后，可以删除编辑要点的图案数据。请反覆步骤 4、步骤 5 进行数据编辑。

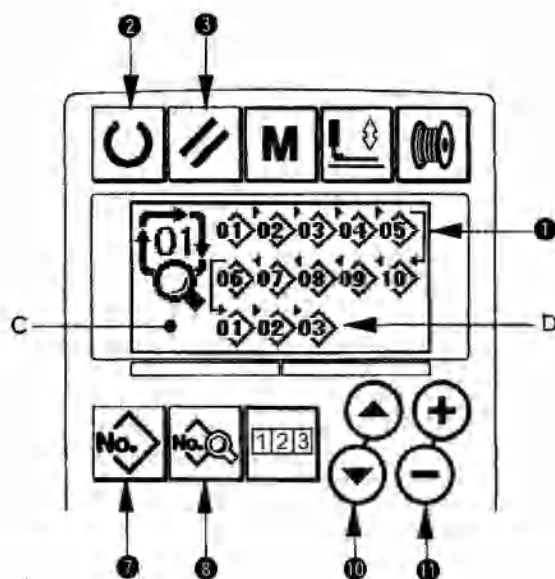

5-19. 切刀数次动作的说明

本缝纫机安装的切刀尺寸由操作盘来进行设定，自动地让切刀进行数次动作，因此可以缝制比切刀尺寸大的扣眼。不更换切刀而要缝制各种各样的形状时，请设定

(1) 切刀数次动作的设定

1) 设定为输入模式

液晶显示 ① 的背景照明为蓝色的输入模式时，可以编辑存储器开关数据。背景照明为绿色的缝制模式时，请按准备键 ② ，变换为输入模式。

2) 输入切布刀尺寸

按模式键 ④ ，显示出存储器开关数据（等

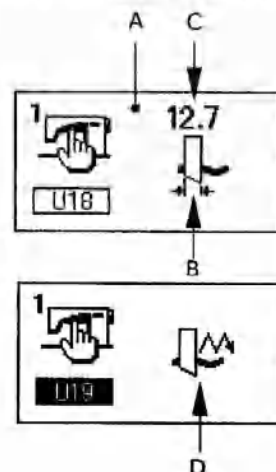

5. 缝纫机的操作

级 1) 编辑画面 A。按项目选择键 **10** **▲** **▼**，叫出 **U18** 布切刀尺寸 B。然后用数据变更键 **11** **+** **-** 设定安装的切刀尺寸 C。详细内容请参照 21. 存储器开关数据一览表。

3) 把布切刀数次动作设定为有效

接着，再次按项目选择键 **10** **▲** **▼**，叫出 **U19** 布切刀数次动作功能 D。然后用数据变更键 **11** **+** **-** 把切刀数次动作设定为有效状态。详细内容请按照 5-21. 存储器开关数据一览表。

4) 进行缝制

按准备键 **2** **U** 之后，液晶显示 **1** 的背景照明变为绿色，成为可以缝制的状态。此时，S02 布切刀长度被上述设定为 U18 布切刀尺寸以上之后，自动地进行数次动作。

如果缝制比安装的切刀尺寸小的扣眼的话，将显示错误 489。

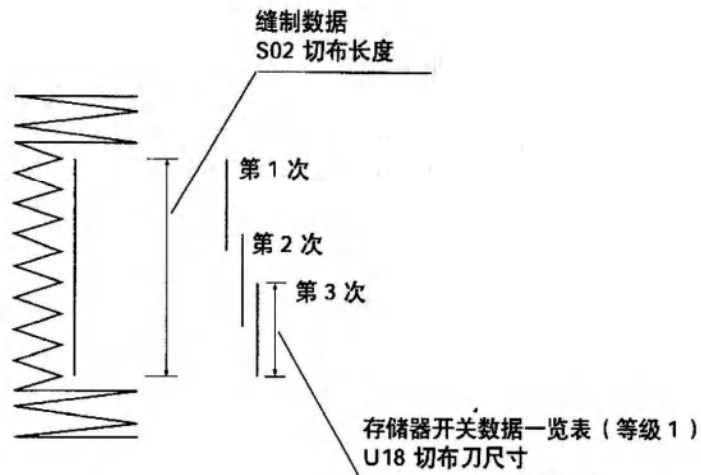
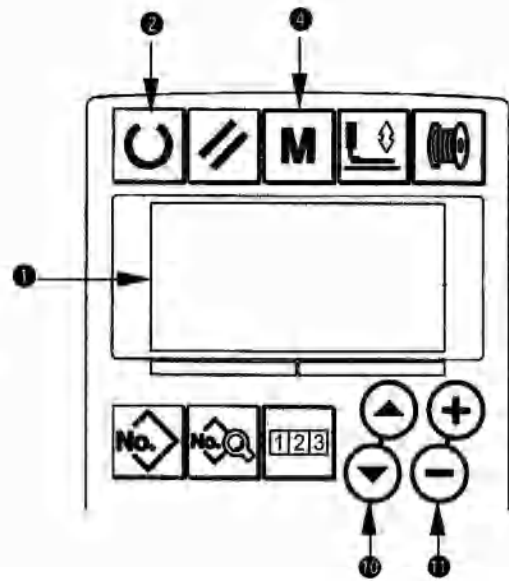

5-20. 存储器开关数据的变更方法

1) 设定输入模式



液晶显示 ❶ 的背景照明为蓝色的输入模式时，存储器开关数据可以进行变更。背景照明为绿色的缝制模式时，请按准备键 ❷  变换成输入模式。

2) 叫出存储器开关数据编辑画面

按模式键 ❸  之后，显示出存储器开关数据（等级 1）编辑画面 A。



再继续按 3 秒钟之后，显示出存储器开关数据（等级 2）编辑画面 B。



3) 选择变更的存储器开关数据

按项目选择键 ❹  ，选择想变更的数据项目。

4) 变更数据

存储器开关数据中，有变更数值的数据项目和选择的数据项目。

变更数值的项目标有  那样的 NO.，用变更数据键 ❺  ，可以增减变更设定值。

选择图标的数据项目有  那样的 NO.，用变更数据键 ❻  ，可以选择图标。

→ 存储器开关数据的详细内容，请参照 5-21。

存储器开关数据一览表。

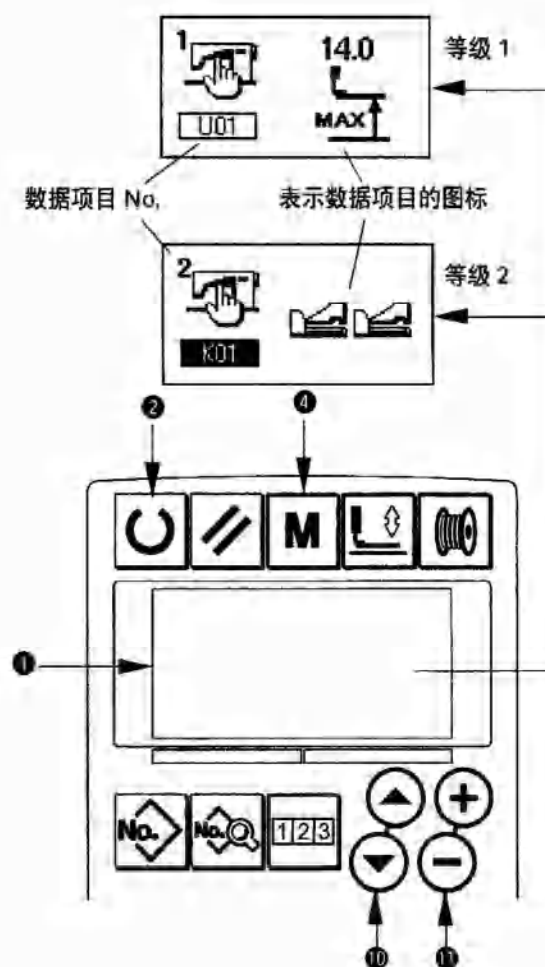













5. 缝纫机的操作

5-21. 存储器开关数据一览表

(1) 等级 1

☆存储器开关数据（等级 1）是缝纫机通用的动作数据，是所有的缝制图案通用的数据。

No.	项目	设定范围	编辑单位	初期值
U01	压脚提升最高位置 设定踏板动作的最高位置的高度。 	0 ~ 17.0	0.1mm	14.0mm
U02	压脚提升中间位置 设定踏板动作的中间位置的高度。 	0 ~ 14.0	0.1mm	6.0mm
U03	压脚提升布安放位置 设定踏板动作的布安放位置的高度。 	0 ~ 14.0	0.1mm	0.0mm
U04	双踏板的踩入位置 (%) 设定双踏板时的操作感觉。详细内容参照下列内容。 	5 ~ 95	1%	80%
U05	双踏板的压脚提升上升位置 (%) 设定双踏板时的操作感觉。 	5 ~ 95	1%	50%
U06	缝制结束上线张力的设定 	0 ~ 200	1	35
U07	切线时的上线面张力的设定 	0 ~ 200	1	35
U08	缝合下缝的上线张力的设定 	0 ~ 200	1	60
U09	软起动速度的设定 第 1 针 	400 ~ 4200	100rpm	800rpm
U10	软起动速度的设定 第 2 针 	400 ~ 4200	100rpm	800rpm
U11	软起动速度的设定 第 3 针 	400 ~ 4200	100rpm	2000rpm
U12	软起动速度的设定 第 4 针 	400 ~ 4200	100rpm	3000rpm
U13	软起动速度的设定 第 5 针 	400 ~ 4200	100rpm	4000rpm
U14	压脚种类 请设定压脚的种类。→ 4. 输入压脚类型 	—	—	1 型
U15	压脚尺寸宽度 U14 压脚类型设定为 5 型后 请输入压脚的宽度。 	3.0 ~ 10.0	0.1mm	3.0mm
U16	压脚尺寸长度 U14 压脚类型设定为 5 型后 请输入压脚的长度。 	10.0 ~ 120.0	0.5mm	10.0mm
U17	缝制开始位置（送布方向） 设定与压脚相对的缝制开始位置。 根据布层想调整开始位置时进行设定。 	2.5 ~ 110.0	0.1mm	2.5mm

No.	项目	设定范围	编辑单位	初期值
U18	切布刀尺寸 请输入使用的切刀尺寸。 	3.0 ~ 32.0	0.1mm	32.0mm
U19	切布刀数次切布动作机能的无效 / 有效  无效  有效	—	—	无效
U20	切线检测功能 无效 / 有效  无效  有效	—	—	有效
U21	准备键 ON 时压脚位置的选择 (上 / 下) 设定按了准备键后的压脚位置。  压脚上升  压脚下降	—	—	压脚上升
U22	循环缝制结束时压脚位置的选择 (上位置 / 下位置) 设定 1 循环缝制结束之后的压脚位置。 (仅在单踏板设定时有效)  压脚上升  压脚下降	—	—	压脚上升
U23	上线切线动作开始的距离 输入从开始缝制到上线切刀开始张开动作为止的距离。 	0 ~ 15.0	0.1mm	1.0mm
U24	底线切线动作开始的距离 输入从开始缝制到底线切刀开始张开动作为止的距离。 	0 ~ 15.0	0.1mm	1.5mm
U25	更新计数单位 设定更新缝制计数的单位。 	1 ~ 30	1	1
U26	总针数 不显示 / 显示  不显示  显示	—	—	不显示

5. 缝纫机的操作

(2) 等级 2

☆持续 3 秒钟按模式开关, 变成可以编辑的状态。

NO.	项目	设定范围	编辑单位	初期值
K01	踏板选择 设定踏板的类型。→ 3. 踏板的操作方法  双踏板  单踏板 (无中间位置)  单踏板 (有中间位置)	—	—	双踏板
K02	参数设定变更 许可 / 禁止 设定禁止缝制数据, 存储器开关数据的变更。  许可变更  禁止变更	—	—	变更许可
K03	禁止选择压种类的机能 许可 / 禁止 U04 设定禁止压脚种类的变更。  许可变更  禁止变更	—	—	变更许可
K04	缝制形状选择等级 可以扩大可以缝制的缝制形状数。(最大 30 种形状)  No. 12 12 形状  No. 20 20 形状  No. 30 30 形状	—	—	12 形状
K05	切布匹刀动力 设定切布刀的输出动力。 0: 最小动力 → 3: 最大动力 	0 ~ 3	1	1
K06	机种选择 设定缝纫机头部的类型。 0: 标准型 1: 干式 	0 ~ 1	1	0 (标准型)
K07	最大缝制转速的设定 设定缝纫机的最高转速。 K06 机种选择为干式时, 最高转速自动被限制为 3300rpm。 	400 ~ 4200	100rpm	3600rpm
K08	上线张力偏差补正 全面补正上线张力的输出值。 	-30 ~ 30	1	0
K09	上线张力变更值输出时间 变更了上线张力有关的数据后, 仅在设定时间内输出变更值。  无输出  设定时间输出	0 ~ 20	1s	0s
K10	每次基准点检索机能 缝制结束后或者循环缝结束后, 进行原点检索。  无  缝制结束后  循环缝结束后	—	—	无
K11	倒转针提升 允许 / 禁止 U01 压脚提升最高位置被设定为 14.0mm 以上时, 自动地倒转针提升, 缝纫机停机。也可以设定禁止此动作。  许可倒转针提升  禁止倒转针提升	—	—	允许
K12	设定切刀电磁下降时间 	25 ~ 100	5ms	35

No.	项目	设定范围	编辑单位	初期值
K13	设定切刀电磁上升时间 	5 ~ 100	5ms	15
K14	切刀缸筒下降时间 (选购) 	5 ~ 300	5ms	50
K15	Y 送布马达 基准点补正 	-120 ~ 400	1 脉冲 (0.025mm)	0
K16	针摆动马达 基准点补正 	-10 ~ 10	1 脉冲 (0.05mm)	0
K17	压脚提升马达 基准点补正 	-100 ~ 10	1 脉冲 (0.05mm)	0
K18	缝制模式下的图案选择功能 无效 / 有效 	—	—	无效
K19	连续缝制途中切线 允许 / 禁止 	—	—	允许
K20	切布刀返回动力 设定切部刀返回时的输出动力。 	0 ~ 3	1	0
K21	缝制开始底线切线剪的开放量 设定缝制开始底线切线剪的开放量。 	0 ~ 15	1 脉冲	8
K22	压脚提升速度 设定压脚提升速度。 	1 ~ 3	—	2
K51	上线切线调整模式开始 用准备键 ON 开始上线切线动作的调整。 	—	—	—
K52	底线切线调整模式开始 用准备键 ON 开始底线切线动作的调整。 	—	—	—
K53	传感器确认模式开始 用准备键 ON 开始确认传感器。 	—	—	—

6、保养

6-1. 机针和旋梭的同步调整



注意

为了防止突然起动能造成人身事故，请关掉电源，确认马达确实停止转动后再进行操作。

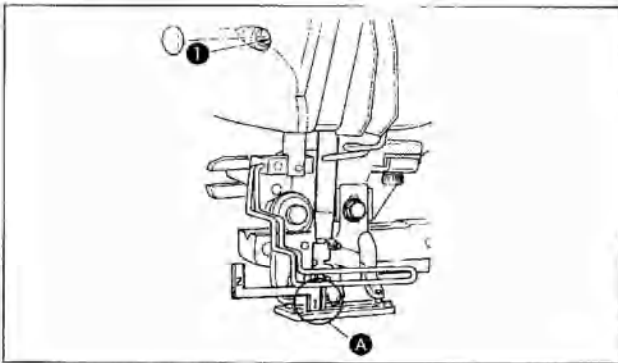

机针和旋梭的同步调节，请在机针落到针板孔的中央时调整。

(1) 针杆高度

- 1) 把针杆降到最下点。
- 2) 把同步尺 [1] **A** 的部分如图所示插入针板和针杆下端之间，针杆碰到规尺。
- 3) 拧松针杆套管固定螺丝 **1**，决定针杆高度。

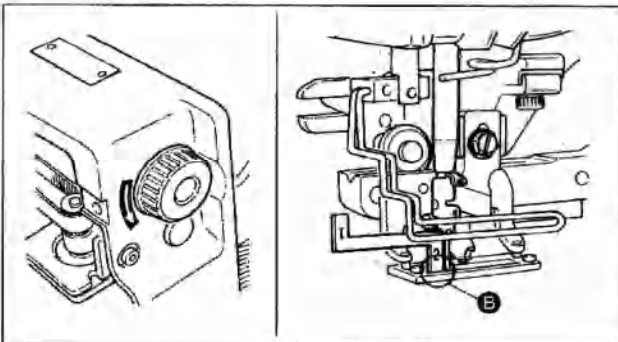

(2) 机针和旋梭的同步

- 1) 按正规的转动方向转动手转动轮，让机针从最下点开始上升。
- 2) 把同步规尺 [2] **B** 的部分插入针板和针杆下端之间，让针杆顶到规尺。
- 3) 拧松轴套固定螺丝 **C**，把旋梭尖调整到机针的中心。
此时，机针与旋梭尖之间的间隙为约 0.05mm。

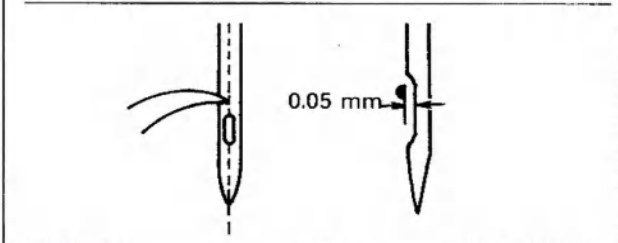
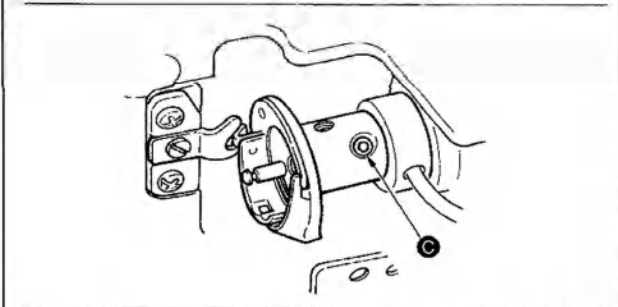

(3) 内旋梭的固定调整

用固定螺丝 **3** 把内旋梭固定器 **1** 的前端和内旋梭 **2** 的端面的咬合调整为 0 ~ 0.2mm。

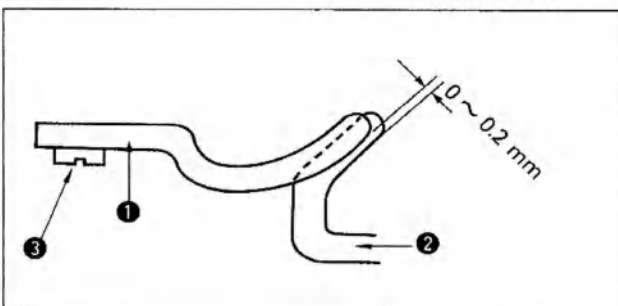

6-2. 上线切线的调整

**注意**

为了防止突然起动造成人身事故，请关掉电源，确认马达确实停止转动后再进行操作。

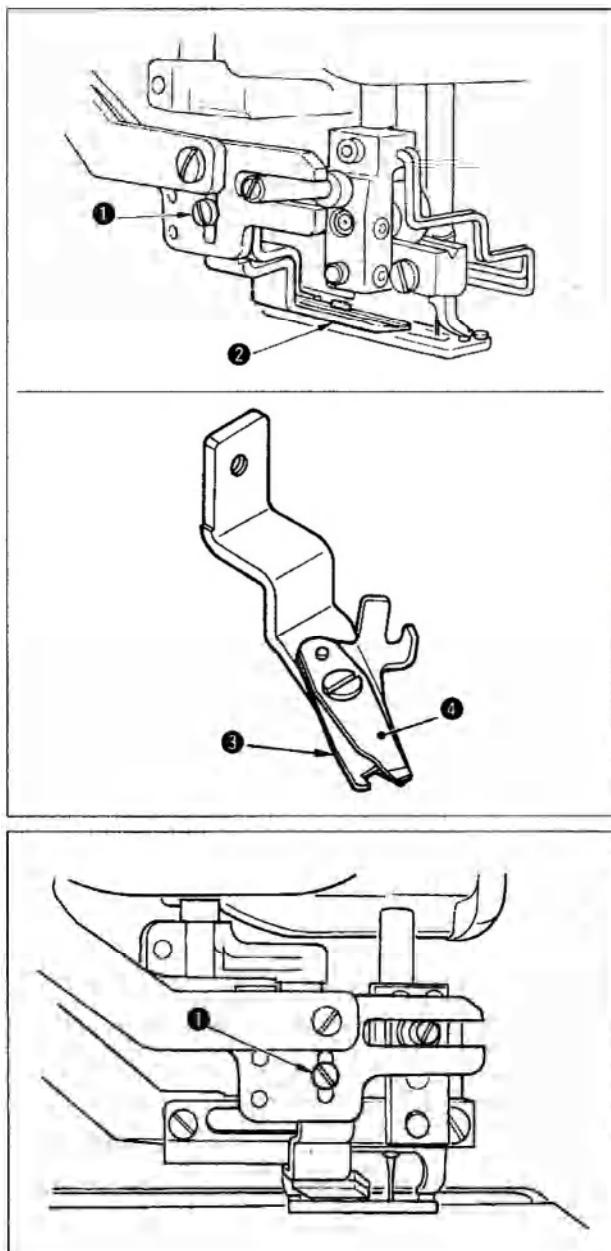

(1) 上线切刀的切线力的调整

上线切刀切线力不稳定的话，始缝时上线容易跳线。

- 1) 上线切线力弱时，拧松螺丝 ①，卸下上线切刀 ②。
- 2) 用手把压线弹簧前端轻轻弄弯，把压线弹簧 ③ 和上切刀 ④ 的接触间隙调整为没有间隙。

(2) 上切刀的安装高度

请拧松上切刀安装螺丝 ① 调整上切刀的安装刀度。请尽量使上切刀和压脚不接触。这样上线切线残线长度短。

但是缝纫多层部时，压脚会倾斜。请把位置稍稍提高，不让切刀与压脚相碰。



更换了上线切线切刀之后，请确认在上线切线调整模式（存储器开关等级 2: K51）下切刀是否正常动作。

6-3. 布压脚压力的调整

**注意**

为了防止突然起动造成人身事故，请关掉电源，确认马达确实停止转动后再进行操作。

6. 保养

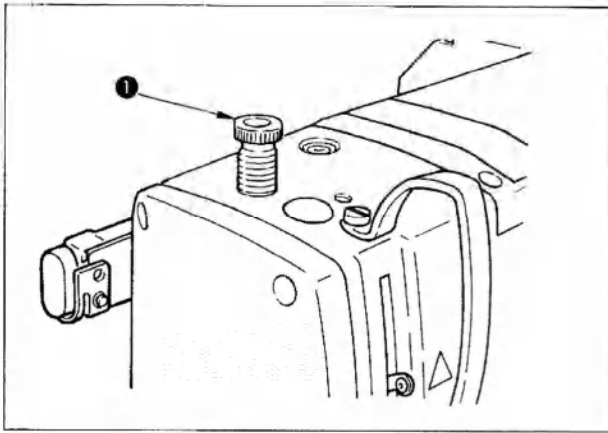

布压脚的压力用压脚调节螺丝①调节。拧紧调节螺丝①后，布压脚压力变大，布不容易出褶。

6-4. 旋梭压片装置的调整



注意

为了防止突然起动造成人身事故，请关掉电源，确认马达确实停止转动后再进行操作。

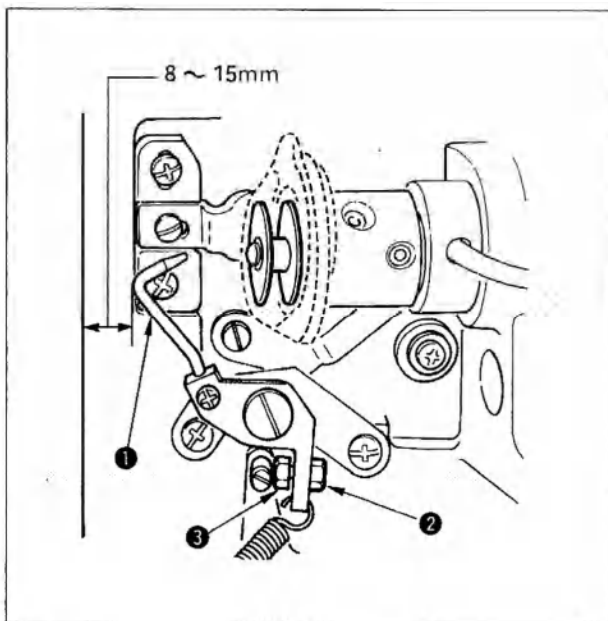

缝纫机停止时，拧松螺母②把机台前端和旋梭压脚①的距离调整为8~15mm，然后用止动器螺丝③调整位置，再拧紧螺母②。

6-5. 线张力

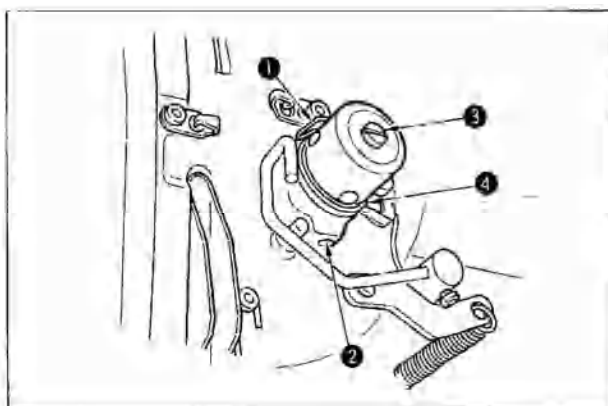

(1) 挑线弹簧（直锁眼缝）

- 1) 挑线弹簧①的挑线量为8~10mm，始动强度0.06~0.1N左右较为适当。
- 2) 改变挑线弹簧的动作量时，请拧松螺丝②，把细螺丝刀插到线张力杆③的缺口部转动调节。
- 3) 改变挑线弹簧的强度时，请在螺丝②拧紧的状态下，把细螺丝刀插到线张力杆③的缺口部转动调节。向右转动之后，挑线弹簧的强度变强，向左转动之后，强度变弱。

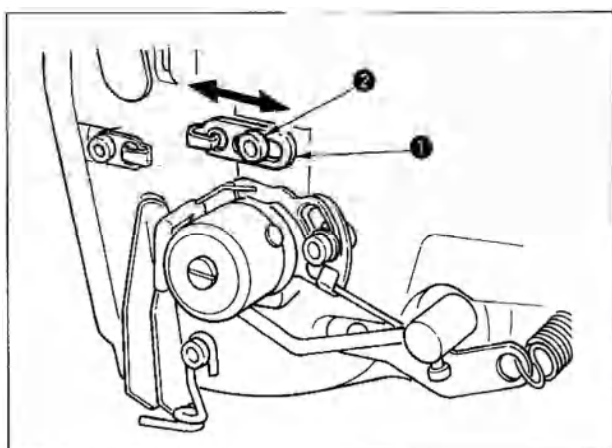
**(2) 挑线杆挑线量的调整**

挑线杆的挑线量，根据布料的厚度进行调节。

- a. 缝制厚料时，拧松导线器 ① 的固定螺丝 ②，向左移动导线器。
- b. 缝制薄料时，把导线器 ① 向右移动。挑线杆的挑线量变少。

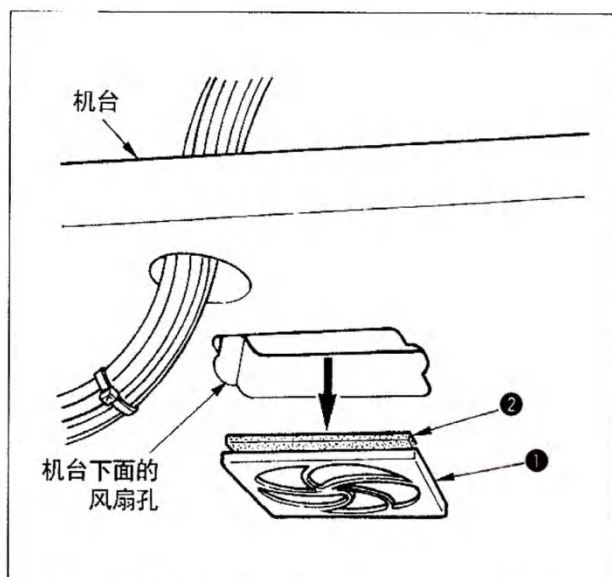
6-6. 滤清器的清扫

请每周清扫机台下面的风扇过滤器 ②。

- 1) 沿箭头方向拉过滤网 ①，把它卸下来。
- 2) 用水冲洗清扫滤清器 ②。
- 3) 把滤清器 ②、过滤网 ① 安装到原来的位置。

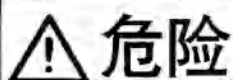
6-7. 保险丝的更换

1. 为了防止触电事故，关掉电源 5 分钟之后再打开外罩。
2. 请一定关掉电源开关之后再打开控制箱的盖子，更换规定容量的保险丝。

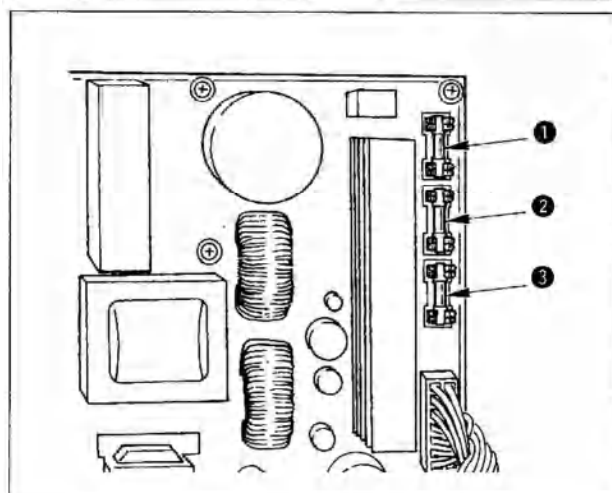

使用 3 个保险丝。

- ① 脉冲马达电源保护用
5A (延时保险丝)
- ② 电磁、脉冲马达电源保护用
3.15A (延时保险丝)
- ③ 控制电源保护用
2A (速断型保险丝)

7、标准部件

7-1. 切布刀

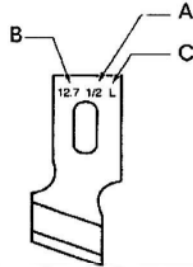

A 切刀尺寸 (英寸)	B 切刀尺寸 (mm)	C 记号	D 货号
1/4	6.4	F	CS2702047F
3/8	9.5	K	CS2702047K
7/16	11.1	I	CS2702047I
1/2	12.7	L	CS2702047L
9/16	14.3	V	CS2702047V
5/8	15.9	M	CS2702047M
11/16	17.5	A	CS2702047A
3/4	19.1	N	CS2702047N
7/8	22.2	P	CS2702047P
1	25.4	Q	CS2702047Q
1-1/4	31.8	S	CS2702047S

7-2. 货号

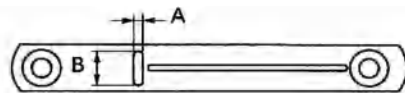

规格	摆动幅度 5mm (刻印 · Ax B)	6mm (刻印 · Ax B)
标准 (S)	CS79004350 (S5 · 1.4x6.2)	CS79004351 (S6 · 1.4x7.4)
针织物用 (K)	CS79004352 (K5 · 1.2x6.2)	CS79004353 (K6 · 1.2x7.4)

7-3. 压脚

摆动幅度 5mm

规格	尺寸 (Ax B)	1 (4x25)	2 (5x35)	3 (5x41)
标准 (S)		CS01552781	CS01552782	CS01552783
针织物用 (K)		CS01508771	CS01508772	CS01508773

摆动幅度 6mm

规格	尺寸 (Ax B)
标准 (S)	3 (6x41) CS014524409

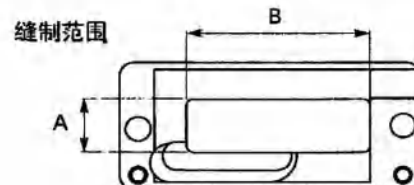

8、错误代码一览表

错误代码		错误内容	复位方法	复位地点
E001		主控制电路板的 EEPROM 初始化 EEP-ROM 里没有写入数据, 或数据损坏时, 自动进行通知进行了初始化。	电源 OFF	
E007		主轴马达被锁定 缝制了大于机针阻抗的缝制物后	电源 OFF	
E018		EEP-ROM 的形式不对 安装的 EEPROM 形式不对时	电源 OFF	
E023		检测出压脚提升马达异常 通过压脚提升马达原点传感器时和动作开始时马达异常时	复位后可以重新启动	标准画面
E024		图案数据尺寸超过 连续缝制数据的总尺寸和下载的数据尺寸过大, 不能进行缝制时	复位后可以重新启动	标准画面
E025		检测出上线切线马达异常 通过上线切线马达原点传感器时和动作开始时马达异常时	复位后可以重新启动	标准画面
E026		检测出底线切线马达异常 通过底线切线马达原点传感器时和动作开始时马达异常时	复位后可以重新启动	标准画面
E030		针杆上位置偏离 缝纫机启动时, 让机针上动作, 但是机针不能在上位置停止时	复位后可以重新启动	标准画面
E050		停止开关 缝纫机启动途中按了停止开关时	复位后可以重新启动	步骤画面
E052		断线检测错误 缝纫机启动途中发生了断线时	复位后可以重新启动	步骤画面
E061		存储器开关数据错误 存储器开关数据损坏或是版本老时	电源 OFF	
E062		缝制数据错误 缝制数据损坏或是版本老时	电源 OFF	
F099		切刀下降指令和切线动作相碰 外部数据动作时, 切刀指令的插入位置不对, 与切线动作相冲突时	复位后可以重新启动	标准画面
E302		放倒机头进行确认 放倒机头, 传感器 OFF 时	复位后可以重新启动	标准画面
E303		主轴 Z 相传感器异常 缝纫机马达编码器的 Z 相传感器异常	电源 OFF	
F304		切布刀传感器错误 切刀下降时传感器关不了时。	电源 OFF	
E486		圆头扣眼长度错误 圆头扣眼形状时圆头扣眼切刀长度过短无法缝制	复位后可以重新启动	缝制数据编辑画面 [S17] 圆头扣眼切刀长度
F487		圆头扣眼形状错误 圆头扣眼形状时圆头扣眼形状长度过短无法缝制	复位后可以重新启动	缝制数据编辑画面 [S14] 圆头扣眼形状长度
E488		锥形加固矫正错误 锥形加固形状时加固长度过短无法缝制	复位后可以重新启动	缝制数据编辑画面 [S08] 第 2 加固缝长度

8. 错误代码

错误代码		错误内容	复位方法	复位地点
E489		切刀尺寸错误 (数次动作时) 切刀尺寸比切布刀尺寸大时	复位后可以重新启动	缝制数据编辑画面 [S02] 切布长度
E492		下缝的压脚尺寸超过 下缝的运针数据超过压脚尺寸时	复位后可以重新启动	缝制数据编辑画面 [S40] 下缝落针补正
E493		缝制结束加固缝的压脚尺寸超过 缝制结束加固缝的运针数据超过压脚尺寸时	复位后可以重新启动	缝制数据编辑画面 [S67] 缝制结束加固缝宽度
E494		缝制开始加固缝的压脚尺寸超过 缝制开始加固缝的运针数据超过压脚尺寸时	复位后可以重新启动	缝制数据编辑画面 [S64] 缝制开始加固缝宽度
E495		压脚尺寸错误 (仅宽方向, 右侧) 运针数据仅超过压脚的宽度方向右侧的尺寸时	复位后可以重新启动	缝制数据编辑画面 [S03] 右切刀槽宽
E496		压脚尺寸错误 (仅宽方向, 左侧) 运针数据仅超过压脚的宽度方向左侧的尺寸时	复位后可以重新启动	缝制数据编辑画面 [S04] 左切刀槽宽 或 [S06] 左右形状比率
E497		压脚尺寸错误 (长度方向, 面前) 运针数据超过压脚长度方向面前的尺寸时	复位后可以重新启动	标准画面
E498		压脚尺寸错误 (宽方向, 左右) 运针数据超过压脚的宽方向左右两侧的尺寸时	复位后可以重新启动	缝制数据编辑画面 [S05] 左包缝宽度
E499		压脚尺寸错误 (长度方向, 里侧) 运针数据超过压脚的长度方向里侧的尺寸时	复位后可以重新启动	缝制数据编辑画面 [S02] 切布长度
E703		操作盘连接到设定外的缝纫机上 (机种错误) 初期通讯时, 系统的机种代码不对时	电源 OFF	
E704		系统的版本不对 初期通讯时, 系统软件的版本不对时	电源 OFF	
E730		主轴马达调节器不良, 欠相 缝纫机马达的调节器异常时	电源 OFF	
E731		主轴马达传感器不良, 位置传感器不良 缝纫机马达传感器或位置传感器不良时	电源 OFF	
E733		主轴马达倒转 缝纫机马达倒转时	电源 OFF	
E801		电源欠相 输入电源欠相时	电源 OFF	
E802		检测出电源瞬间断电 输入电源瞬间断电时	电源 OFF	
E811		过高电压 输入电源达 280V 以上时	电源 OFF	
E813		过低电压 输入电源达 150V 以下时	电源 OFF	
E901		主轴马达 IPM 异常 伺服控制基板的 IPM 异常时	电源 OFF	
E902		主轴马达电流过大 缝纫机马达里电流过大时	电源 OFF	
E903		脉冲马达电源异常 伺服控制基板的脉冲马达电源变动 $\pm 15\%$ 以上时	电源 OFF	

错误代码		错误内容	复位方法	复位地点
E903		脉冲马达电源异常 伺服控制基板的脉冲马达电源变动 $\pm 15\%$ 以上时	电源 OFF	
E904		继电器电源异常 伺服控制基板的继电器电源变动 $\pm 15\%$ 以上时	电源 OFF	
E905		伺服控制电路板用热敏温度异常 伺服控制电路板的热敏电阻达 85 以上时	电源 OFF	
E907		机针摆动马达原点检索错误 原点检索动作时，原点传感器信号没有被输入时	电源 OFF	
F908		Y 送马达原点检索错误 原点检索动作时，原点传感器信号没有被输入时	电源 OFF	
E909		上线切线马达原点检索异常 原点检索动作时，原点传感器信号没有被输入时	电源 OFF	
F910		压脚马达原点检索错误 原点检索动作时，原点传感器信号没有被输入时	电源 OFF	
E911		底线切线马达原点检索异常 原点检索动作时，原点传感器信号没有被输入时	电源 OFF	
E915		操作盘 \leftrightarrow 主 CPU 间通讯异常 数据通讯时发生异常后	电源 OFF	
E916		主 CPU 主轴 \leftrightarrow CPU 间通讯异常 数据通讯时发生异常后	电源 OFF	
E918		主控制电路板用热敏电阻温度异常 主控制电路板的热敏电阻达 85C 以上时	电源 OFF	
E943		主控制电路板的 EEPROM 不良 EEPROM 不能写入时	电源 OFF	
E946		机头部连接电路板 EEPROM 不能写入 EEPROM 不能写入时	电源 OFF	
E999		布切刀不能返回原位时 <ul style="list-style-type: none"> • 布切刀在规定时间后不能返回原位时 • 切布刀上升时（待机时）传感器不动作时。 	电源 OFF	

9. 故障的现象与原因·处理对策

现象	原因	处理对策	页
1. 上线断线	1. 平行部线张力过强。 2. 挑线弹簧的强度过强, 移动量过大。 3. 旋梭尖部分有毛刺, 有伤痕。 4. 旋锁的同步时间不对。 5. 线道上有伤痕。 6. 机针安装不良。 7. 机针过细。 8. 机针的前端有伤痕。	○ 平行部线张力过弱。 ○ 减弱挑线弹簧的弹力, 或缩小移动量。 ○ 锉平旋梭尖的毛刺, 过更换旋梭。 ○ 用同步规尺调整旋梭的同步时间。 ○ 用布或锉刀锉平伤痕和毛刺。 ○ 调整机针的朝向和高度。 ○ 更换成粗针。 ○ 更换机针。	P.12 P.47 - P.45 - P.11 - -
2. 上线脱线	1. 上线切刀张开过早。 2. 始缝部线勾不到一起。 (始缝的张力过强。) 3. 上线穿线方法不对。 4. 始缝的速度过快。	○ 上线切线时, 夹了打开时间晚。 ○ 减弱始缝张力。 ○ 重新正确地穿线。 ○ 设定软起动。	P.46 P.31 P.12 P.41
3. 平行部缝迹不均匀	1. 平行部线张力过弱。 2. 底线张力过强。 3. 张力过弱	○ 加强平行部线张力。 ○ 减弱底线张力。 (直线锁缝 0.05 ? 0.1N) ○ 增强张力	P.21 P.13 -
4. 始缝缝迹不均匀	1. 平行部线张力过弱。 2. 上线切刀位置过高。 3. 挑线弹簧的移动量过大。	○ 加强平行部张力。 ○ 只要不碰到压脚尽量下降切刀。 ○ 减小挑线弹簧的移动量。	P.21 P.46 P.48
5. 加固缝部上线从布的下面露出, 成团状	1. 加固缝线张力过弱。 2. 底线张力过强。 3. 因呈放射形状, 所以针数多。 4. 结束缝的张力过弱	○ 加强加固缝线张力。 ○ 减弱底线张力。(0.05 - 0.1N) ○ 减少针数。 ○ 加强结束缝张力。	P.21 P.13 P.29 P.41
6. 缝迹鼓起	1. 底线张力过弱。 2. 底线从梭壳脱出来。	○ 加强底线张力。 ○ 重新正确地穿梭完线。 ○ 底线卷绕量绕得不要过多。	P.13 P.12 P.23
7. 锁眼绽出	1. 钮扣孔比压脚小。 2. 缝制薄料时皱缩。 3. 机针安装不好。 4. 机针弯曲。 5. 旋梭尖部有毛刺和伤痕。	○ 把压脚更换成较小的。 ○ 推迟机针和旋梭的同步时间。 (把针杆下降 0.5mm 左右) ○ 重新调整机针的朝向、高度等。 ○ 更换机针。 ○ 用锉刀锉平梭尖。或更换旋梭。	- P.45 P.11 - -
8. 线绽开	1. 固定缝针数少。 2. 固定缝宽度太宽。	○ 增加缝制结束的加固缝针数。 ○ 弄窄缝制结束的加固缝宽度。	P.32 P.32
9. 缝制结束上线留线过长	1. 固定缝宽度过窄。 2. 固定缝张力过弱。	○ 弄宽缝制结束的加固缝宽度。 ○ 加大缝制结束的张力。	P.32 P.41

现象	原因	处理对策	页
10. 始缝时上线断线, 或背面线迹不好看	1. 始缝张力过弱	○ 加强始缝张力。	P31
11. 切上线但切刀不下落。	1. 切线检测板的调整是否良好?	○ 调整检测板(参照服务手册)	-
12. 断针。	1. 机针是否弯曲? 2. 机针和旋梭尖是否相碰? 3. 上线切刀张开时是否碰机针? 4. 机针是否落入针板孔的中心? 5. 机针的停止位置过低, 上线切线刀闭合时是否碰机针?	○ 更换机针 ○ 调整机针和旋梭的同步时间 ○ 调整上线切刀的安装位置 ○ 重新调整针板座的安装位置	P12 P45 P46 -
13. 切刀下落数次。	1. 切布刀是否设定成数次?	○ 接触数次的设定。	P39

1、 NAMES OF MAJOR PARTS

1、 NAMES OF MAJOR PARTS

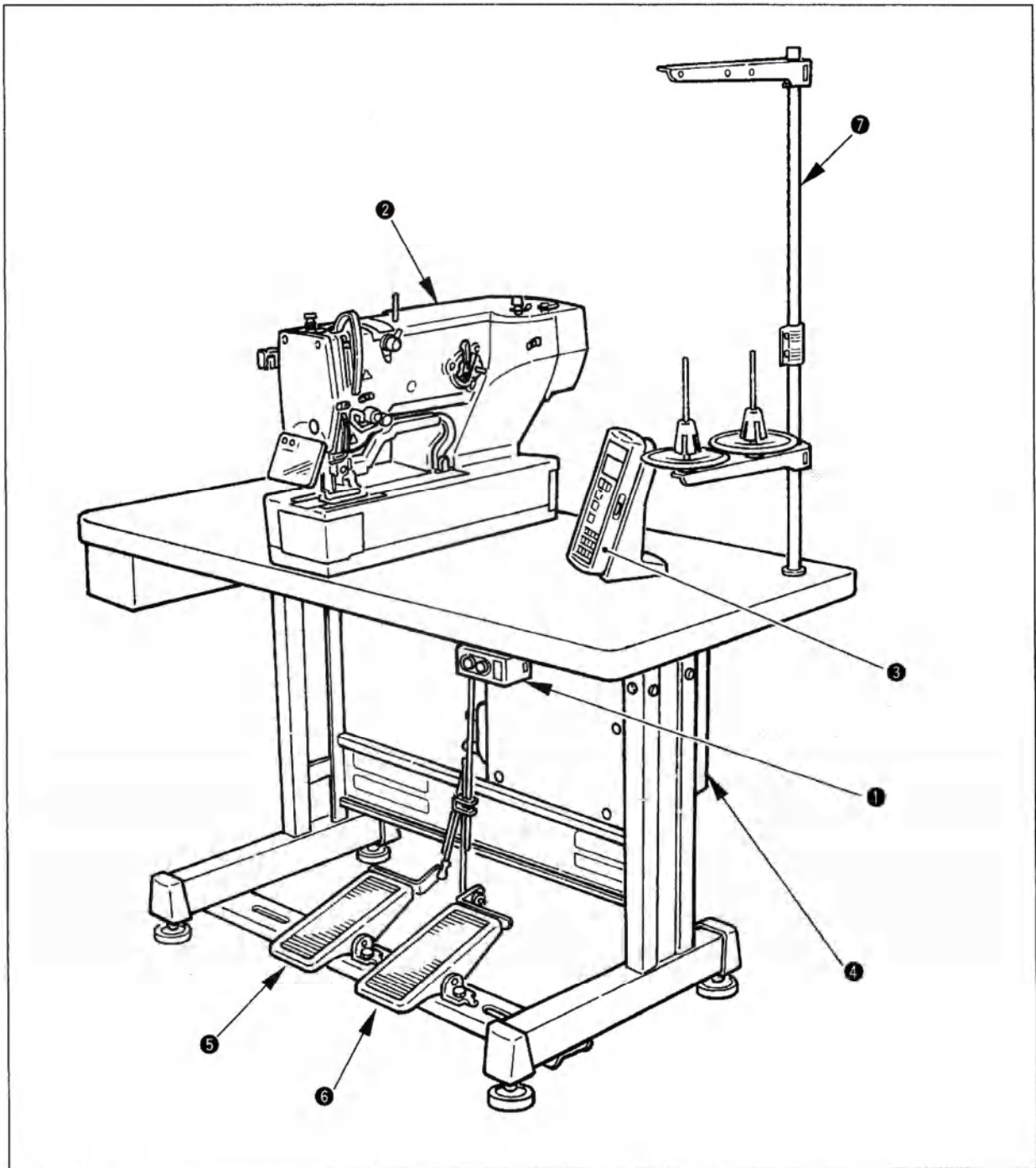

CSM-1790 consists of the following components.

















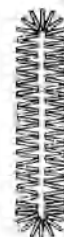







①	Power ON/OFF switch
②	Machine head (CSM-1790)
③	Operation panel
④	Control box (MC-601)
⑤	Presser lifting pedal
⑥	Starting pedal
⑦	Thread stand device

2、SPECIFICATIONS





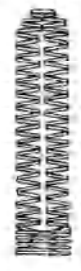













2-1.Specifications

	CSM-1790S	CSM-1790K
Sewing speed	Standard speed: 3600rpm(Max: 4200rpm) (Max: 3300rpm when dry hook is used)	
Needle	DPx5 #11J~#14J	
Hook	DP type full-rotary hook	
Needle rocking drive method	Drive by stepping motor	
Feed drive method	Drive by stepping motor	
Presser lifting drive method	Drive by stepping motor	
Lift of presser foot	14mm(Optional setting available)Max: 17mm(At the time of needle up by reverse run)	
Cloth cutting knife Drive method	By double-acting solenoid drive	
Major application	Buttonholing of cloth such as men's shirts , blouses , work uniforms , ladies 'wear , etc.	Buttonholing of knits such as knitted underwear , sweaters , cardigans , jersey , etc.
Buttonholing size	Standard: Max.5mm; Special type part: Max.10mm Knife size used: 6.4~31.8mm(1/4'~ 1-1/4') Buttonholing sewing length Standard: Max41mm; Special type part: Max.120mm	
Standard sewing Drive method	33kinds	
Number of patterns Stored in memory	99patterns	
Motor used	Single phase220/230/240V,3-phase200to240V,1000VA	

2-2.Standard sewing shape list

(1) Square type	(2) Round type	(3) Radial square type	(4) Radial type	(5) Radial straight bar-tacking type	(6) Radial taper bar-tacking type
 PANEL DISPLAY  1	 PANEL DISPLAY  2	 PANEL DISPLAY  3	 PANEL DISPLAY  4	 PANEL DISPLAY  5	 PANEL DISPLAY  6
(7) Eyelet square type	(8) Eyelet radial type	(9) Eyelet straight bar-tacking type	(10) Eyelet taper bar-tacking type	(11) Semilunar type	(12) Round square type
 PANEL DISPLAY  7	 PANEL DISPLAY  8	 PANEL DISPLAY  9	 PANEL DISPLAY  10	 PANEL DISPLAY  11	 PANEL DISPLAY  12

2. SPECIFICATIONS

 <p>PANEL DISPLAY</p> <p>13</p>	 <p>PANEL DISPLAY</p> <p>14</p>	 <p>PANEL DISPLAY</p> <p>15</p>	 <p>PANEL DISPLAY</p> <p>16</p>	 <p>PANEL DISPLAY</p> <p>17</p>	 <p>PANEL DISPLAY</p> <p>18</p>
(19) Square semilunar type	(20) Square round type	(21) Square straight bar-tacking type	(22) Square taper bar-tacking type	(23) Radial semilunar type	(24) Radial round type
 <p>PANEL DISPLAY</p> <p>19</p>	 <p>PANEL DISPLAY</p> <p>20</p>	 <p>PANEL DISPLAY</p> <p>21</p>	 <p>PANEL DISPLAY</p> <p>22</p>	 <p>PANEL DISPLAY</p> <p>23</p>	 <p>PANEL DISPLAY</p> <p>24</p>
(25) Semilunar radial type	(26) Semilunar round type	(27) Bar-tacking	(28) Bar-tacking, right cut	(29) Bar-tacking, left cut	(30) Bar-tacking, center cut
 <p>PANEL DISPLAY</p> <p>25</p>	 <p>PANEL DISPLAY</p> <p>26</p>	 <p>PANEL DISPLAY</p> <p>27</p>	 <p>PANEL DISPLAY</p> <p>28</p>	 <p>PANEL DISPLAY</p> <p>29</p>	 <p>PANEL DISPLAY</p> <p>30</p>

3. INSTALLATION

3-1. Set-up of table

WARNING :

To prevent possible accidents caused by the fall of the sewing machine, perform the work by two persons or more when the machine is moved.

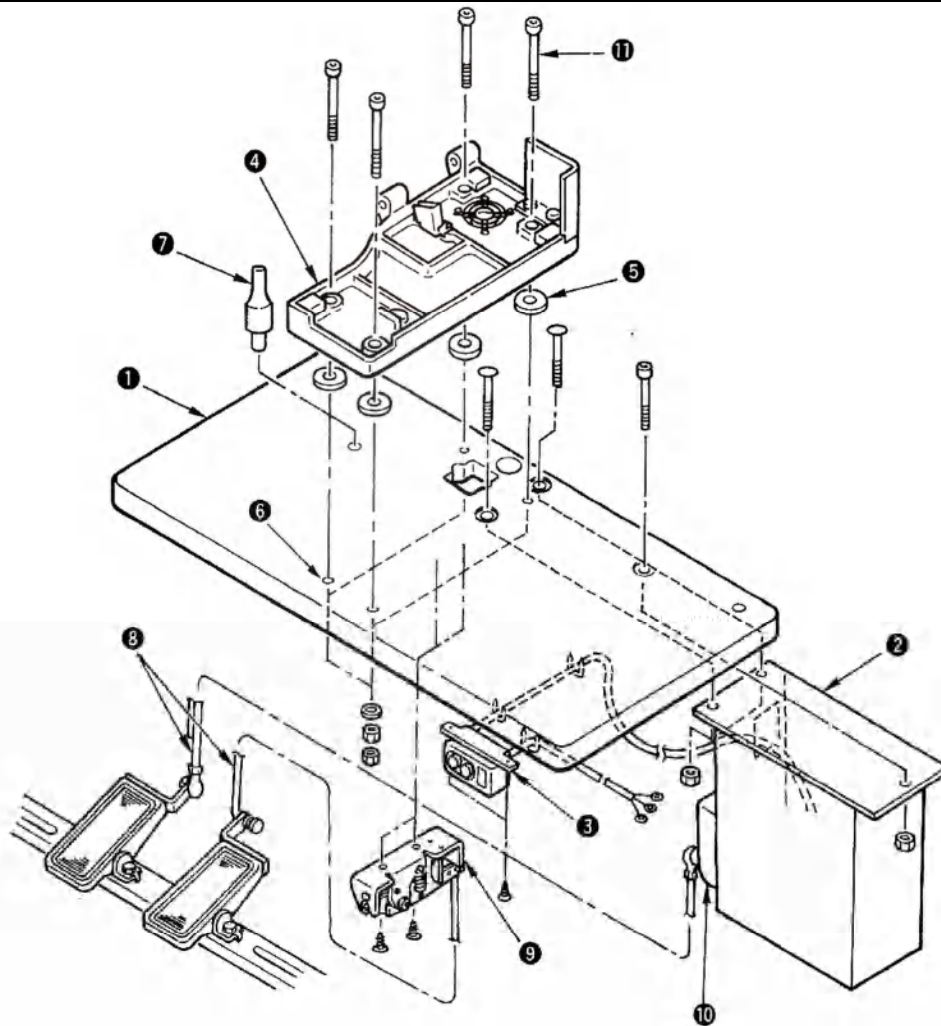

- 1) Securely install control box **2** and power switch **3** on table **1**.
- 2) Securely fix the respective power cables of power switch **3**.
- 3) Pass four bed base fixed screws **11** through bed base **4**.
- 4) Set rubber cushions **5** to holes **6** (4 places) for fixing bed base and fix bed base **4**.
- 5) Fix head support bar **7** on table **1**.
- 6) After placing the sewing machine main unit on bed base **4**, connect pedal (right side) to pedal switch **9**, and pedal (left side) to pedal sensor **10** respectively with connecting rods **8** which have been supplied as accessories.



Adjust the positions of the pedals so that connecting rods **8 and control box **2** do not come in contact with each other.**

3. INSTALLATION

3-2. Connecting the power source cord

- Voltage specifications

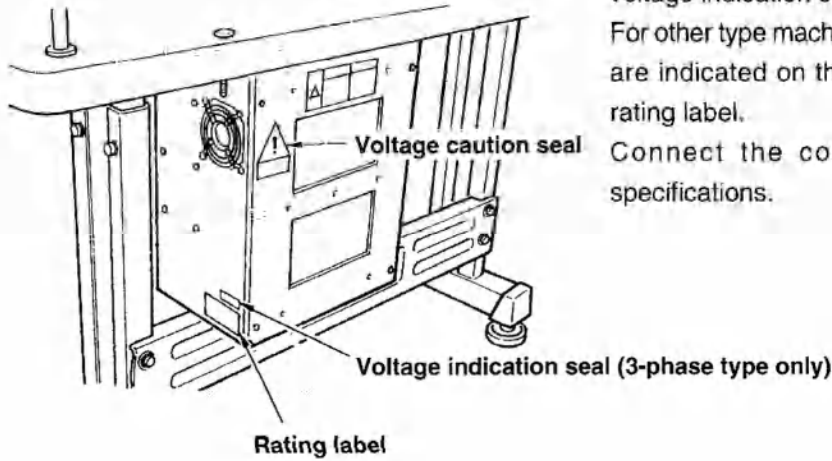

Power source specifications are indicated on the voltage indication seal. (3-phase type only)
For other type machines, power source specifications are indicated on the voltage caution seal and the rating label.
Connect the cord in accordance with the specifications.

- Connecting single phase 200V, 220V, 230V and 240V

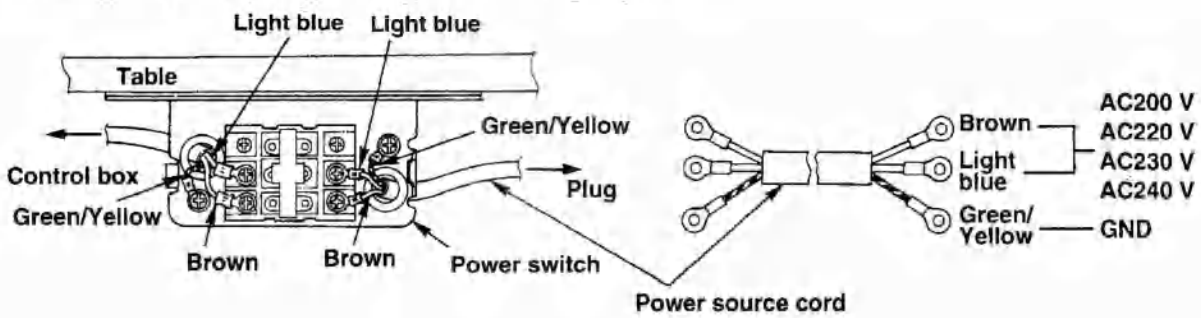

- Connecting three phase 200V, 220V and 240V

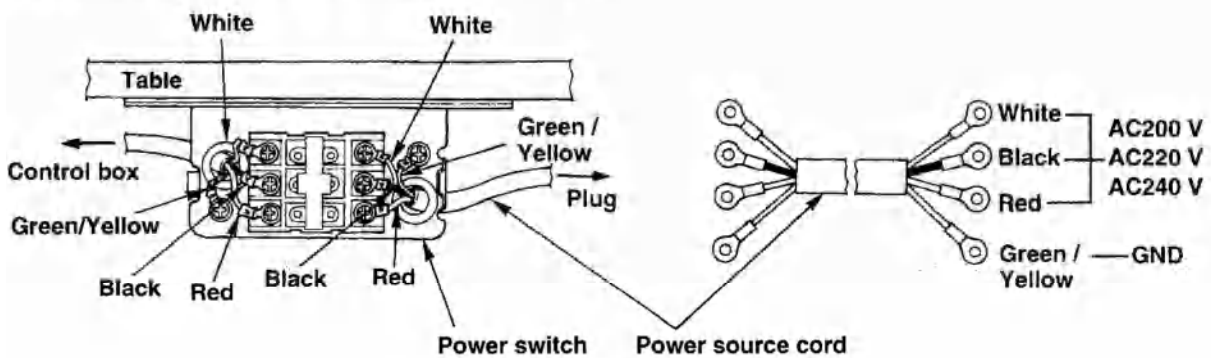

1. Never use under the wrong voltage and phase.
2. When changing the voltage, refer to the item of "Changing the voltage of 100 / 200V".

3-3.Changing the voltage of 100/200

**WARNING :**

To prevent personal injuries caused by electric shock hazards or abrupt start of the sewing machine, carry out the work after turning OFF the power switch and a lapse of 5 minutes or more. To prevent accidents caused by unaccustomed work or electric shock, request the electric expert or engineer of our dealers when adjusting the electrical components.

It is adaptable to the voltage of single phase 100V to 120V/3-phase 200V to 240V by changing the voltage changeover connector mounted on FLT p.c.b.

(Caution) When the changing procedure is wrong, the control box will be broken. So, be very careful.

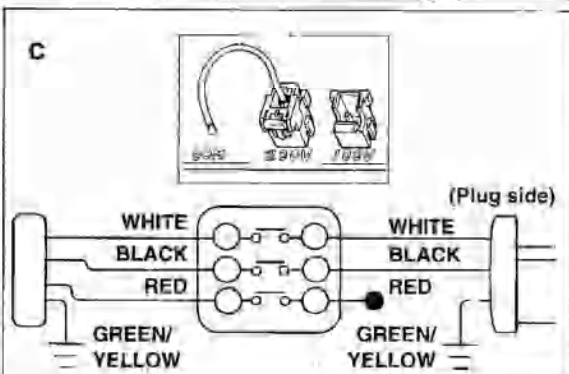
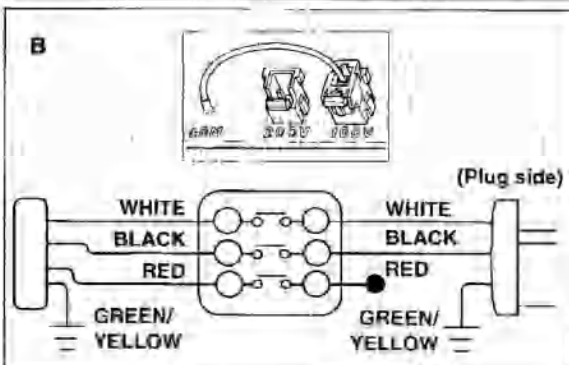
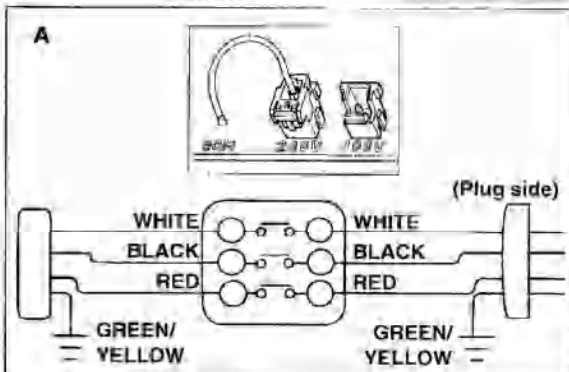
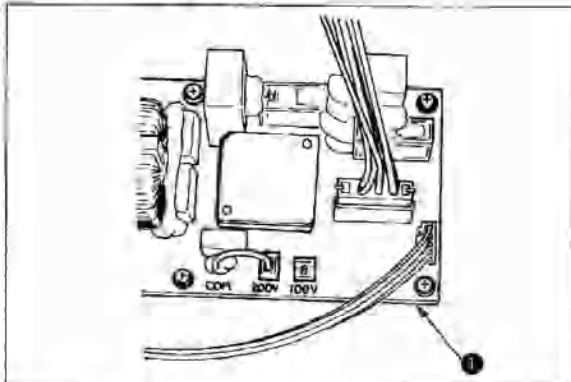

Changing procedure of the changeover connector
1. Turn OFF the power source with the power switch after confirming that the sewing machine has stopped.

2. Draw out the power cord from the power plug socket after confirming that the power switch is turned OFF. Then wait for five minutes or more.

3. Remove the front cover.

4. Remove four screws fixing the rear cover of the control box and slowly open the rear cover.

A. In case of using with 3-phase 200V to 240V

- Changing the changeover connector
Connect to 200V the 100/200V changeover connector of FLT p.c.b. ❶ located on the side of the Box Side of the control box.
- Connect the crimp style terminal of AC input cord to the power plug as shown in the figure.

B. In case of using with single phase 100V to 120V

- Changing the changeover connector
Connect to 100V the 100/200V changeover connector of FLT p.c.b. ❶ located on the side of the Box Side of the control box.
- Connect the crimp style terminal of AC input cord to the power plug as shown in the figure.

(Caution) Securely perform the insulation treatment to the red terminal which is not used with insulation tape or the like.

(When the insulation is insufficient, there is a danger of electric shock or leakage current.)

C. In case of using with single phase 200V to 240V

- Changing the changeover connector
Connect to 200V the 100/200V changeover connector of FLT p.c.b. ❶ located on the side of the Box Side of the control box.
- Connect the crimp style terminal of AC input cord to the power plug as shown in the figure.

(Caution) Securely perform the insulation treatment to the red terminal which is not used with insulation tape or the like.

(When the insulation is insufficient, there is a danger of electric shock or leakage current.)

5. Check that the change has been performed without fail before closing the rear cover.

6. Be careful that the cord is not pinched between the rear cover and the control box main unit. Close the rear cover while pressing the lower side of rear cover, and tighten four screws.

3. INSTALLATION

3-4. Installing the sewing machine main unit

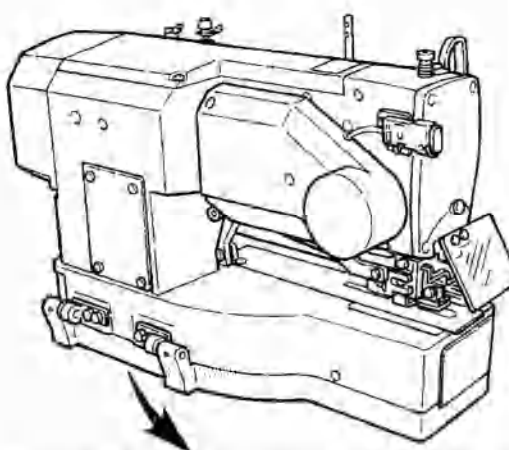

WARNING :
 To prevent possible accidents caused by the fall of the sewing machine, perform the work by two persons or more when the machine is moved.

1) Place hinge plates ❶ and shaft bearings ❷-1 (rubber) and ❷-2 (metal) in two places on the head base and fix the hinge plates to the machine head with setscrews ❸ in two places.

Caution
When the rubber hinge and metal fitting hinge are installed in reverse order, it is dangerous since the sewing machine shakes when it is tilted. So, be careful.

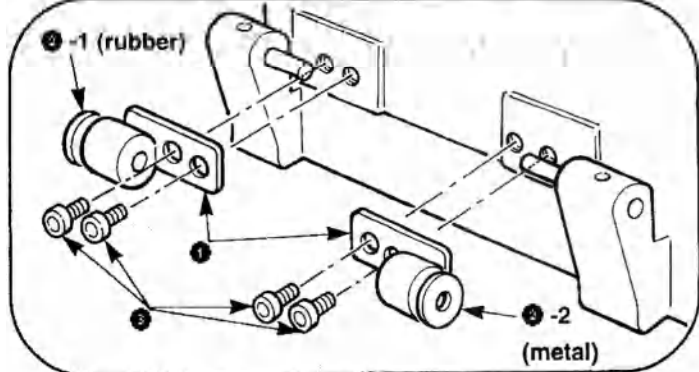

3-5. Tilting the sewing machine head

WARNING :
 When tilting/raising the sewing machine head, perform the work so as not to allow your fingers to be caught in the machine. In addition, to avoid possible accidents caused by abrupt start of the machine, turn OFF the power to the machine before starting the work.

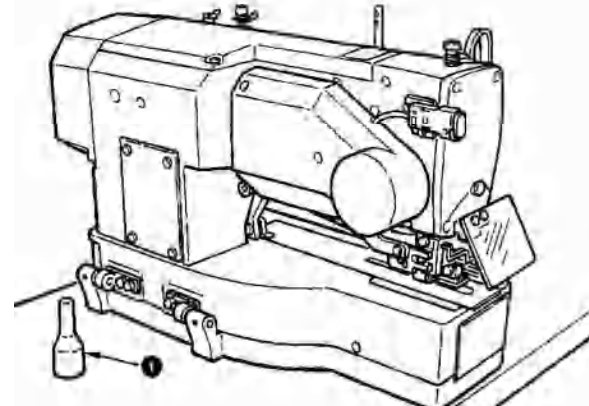

When tilting the sewing machine head, tilt quietly the sewing machine until head support bar ❶ comes in contact with it.

Caution
1. Make sure that sewing machine head support bar ❶ is placed on the table before tilting the sewing machine.
2. To protect fall-down, be sure to tilt the sewing machine in a level place.

3-6. Connecting the safety switch connector

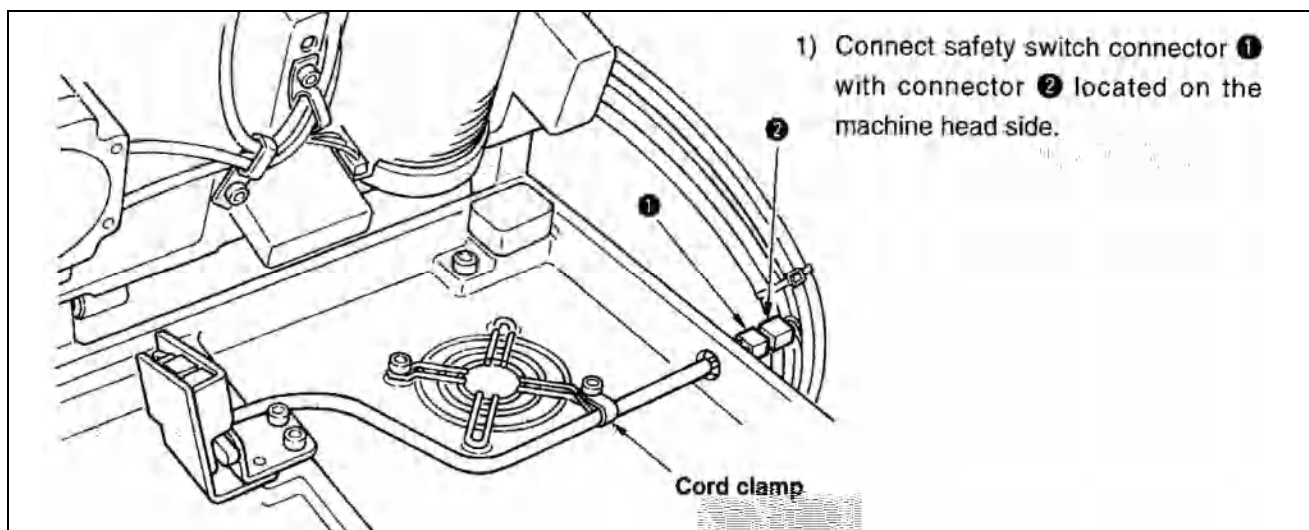

3-7. Installing the hook oil shield plate

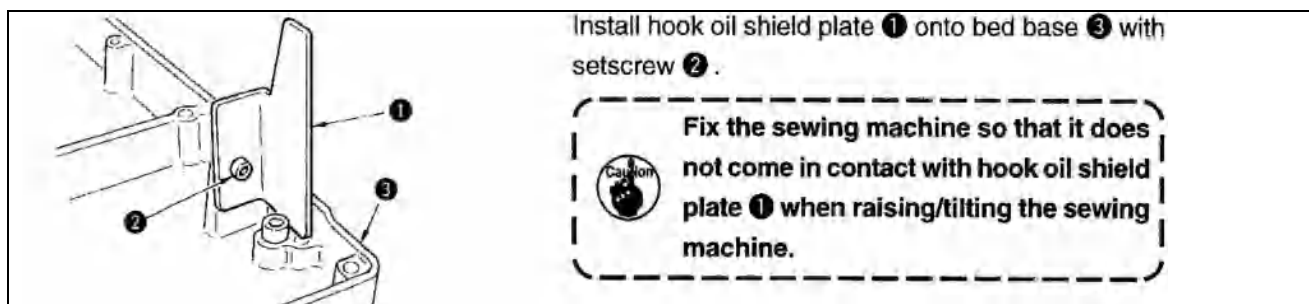

3-8. Installing the operation panel

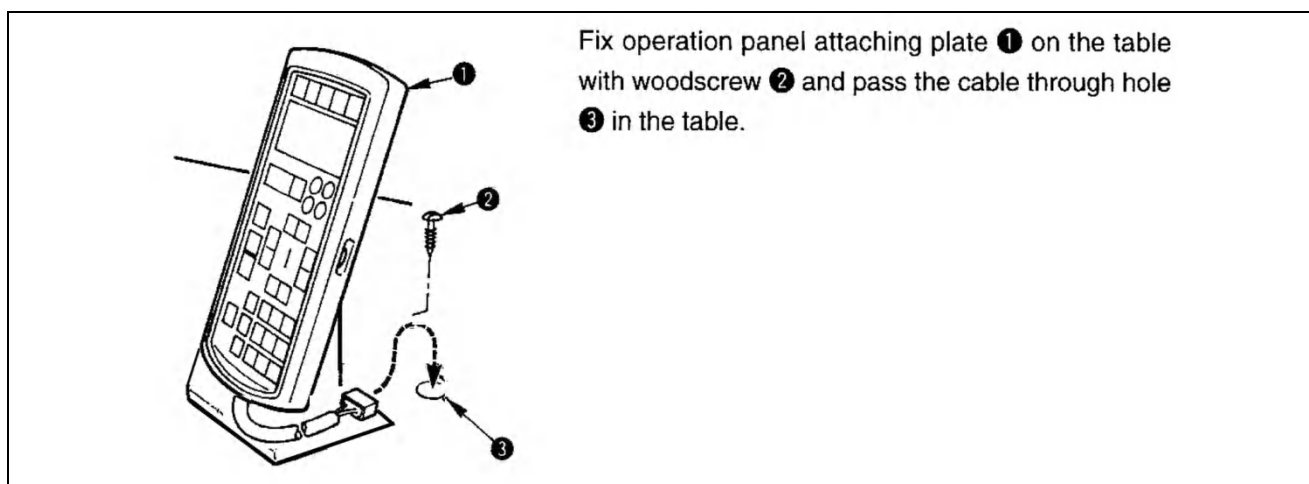

3. INSTALLATION

3-9. Connecting the cords

Perform the connection of the cords as shown in the figure below.

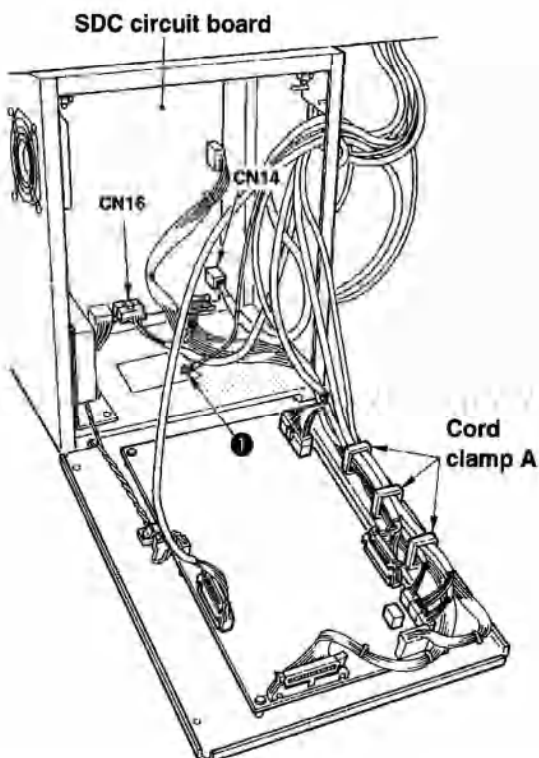
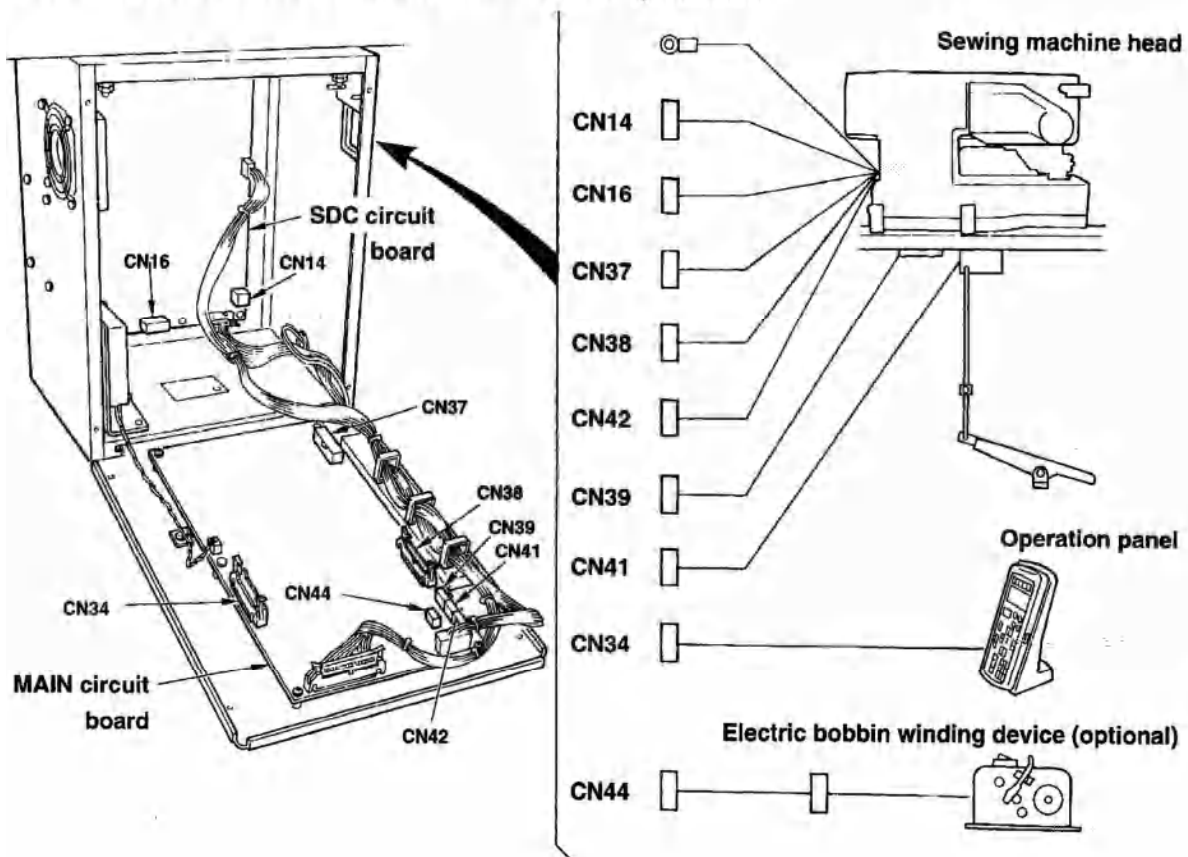

- 1) Pass 4 cords (CN38, 39, 41, and 42) connecting to the right side among the cords connecting to MAIN circuit board through cord clamp A as shown in the figure, and connect them to the respective connectors. Connect CN37 to the connector without passing through cord clamp A. In addition, when using the electric bobbin winding device (optional), similarly pass the cord of the bobbin winding device through the cord clamp and connect it to CN44.
- 2) Directly connect the cord from the operation panel connecting to the left side of MAIN circuit board to CN34.
- 3) Connect the cords connecting to SDC circuit board directly to CN14 and CN16.
- 4) Fix the earth wire with the setscrew ❶.

3-10. Managing the cord

- 1) Slowly tilting the sewing machine, check that the cords are not forcibly pulled.
- 2) Fix the cords with cord setting plate ❶ as shown in the figure.

Caution When you tilt the sewing machine, make sure that the sewing machine head support bar ❷ is placed on the table.

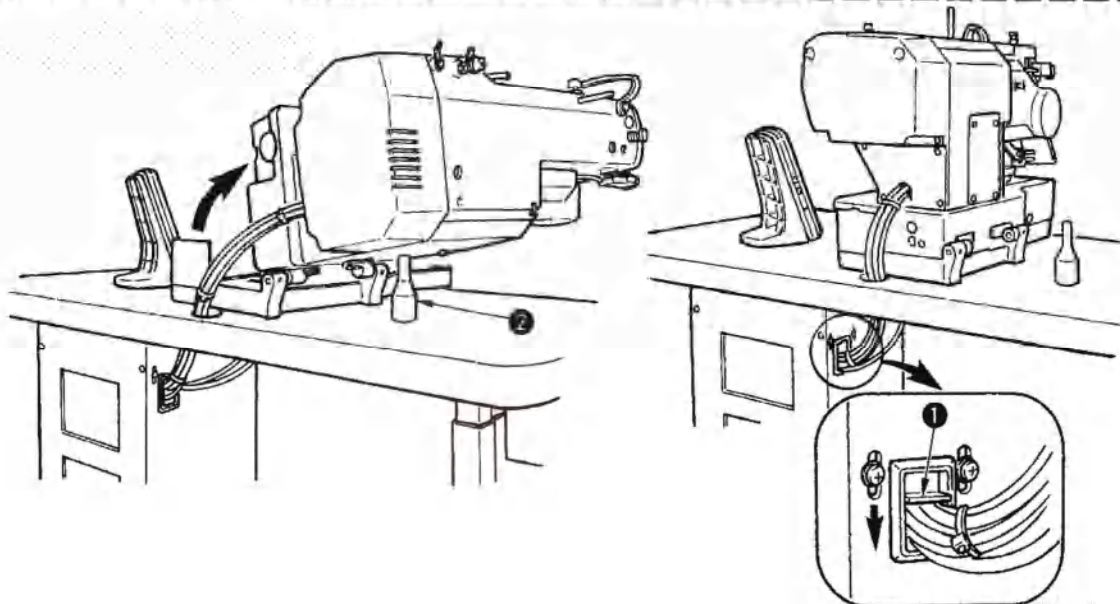

3-11. Installing the eye protection cover



WARNING :

Be sure to attach this cover to protect the eyes from the disperse of needle breakage.

Be sure to install and use eye protection cover ❶ and use the sewing machine.

When placed longitudinally

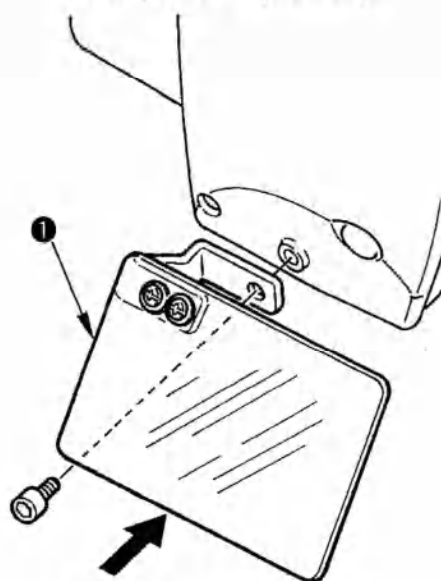

Operator

When placed horizontally

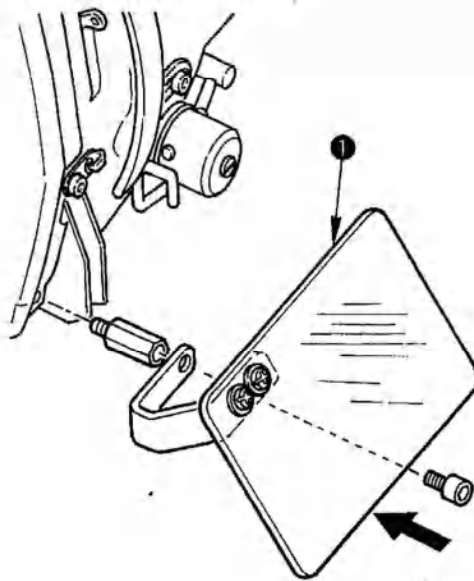

Operator

3. INSTALLATION

3-12. Fixing the temporary stop switch

The temporary stop switch has been in the state as shown in figure A at the time of delivery. Loosen setscrew ❶ and set the switch in the state as shown in figure B, and fix it with setscrew ❶ together with setscrew ❷ supplied with the machine.

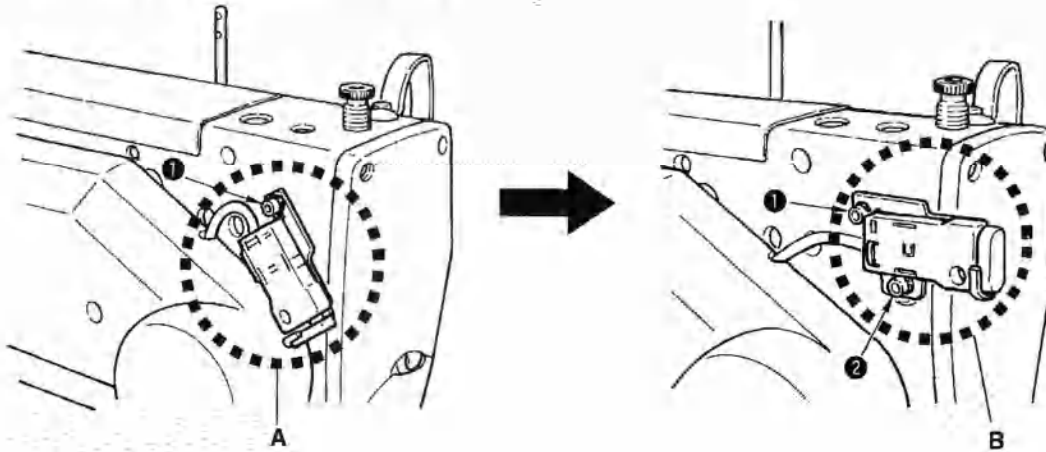

3-13. Thread guide rod

Thread guide rod

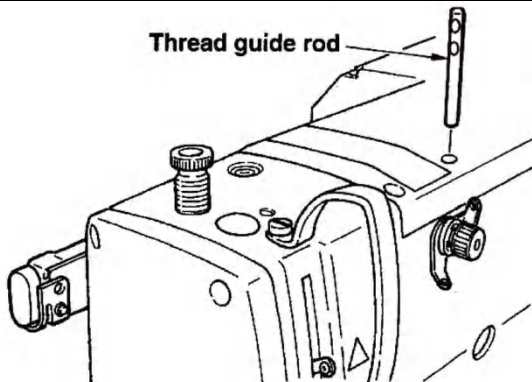

Securely fit the thread guide rod so that two side holes in the thread guide rod face the thread guide.

3-14. Installing the thread stand

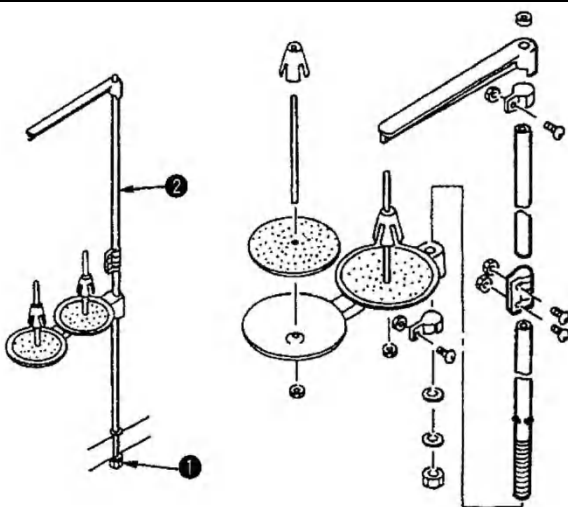

- 1) Assemble the thread stand, and set it in the hole in the top right corner of the machine table.
- 2) Tighten locknut ❶ to fix the thread stand.
- 3) When ceiling wiring is possible, pass the power cable through spool rest rod ❷.

4、 Preparation before operation

4-1.Lubrioation



WARNING :

To protect against possible personal injury due to abrupt start of the machine, be sure to start the following work after turning the power off and ascertaining that the motor is at rest.

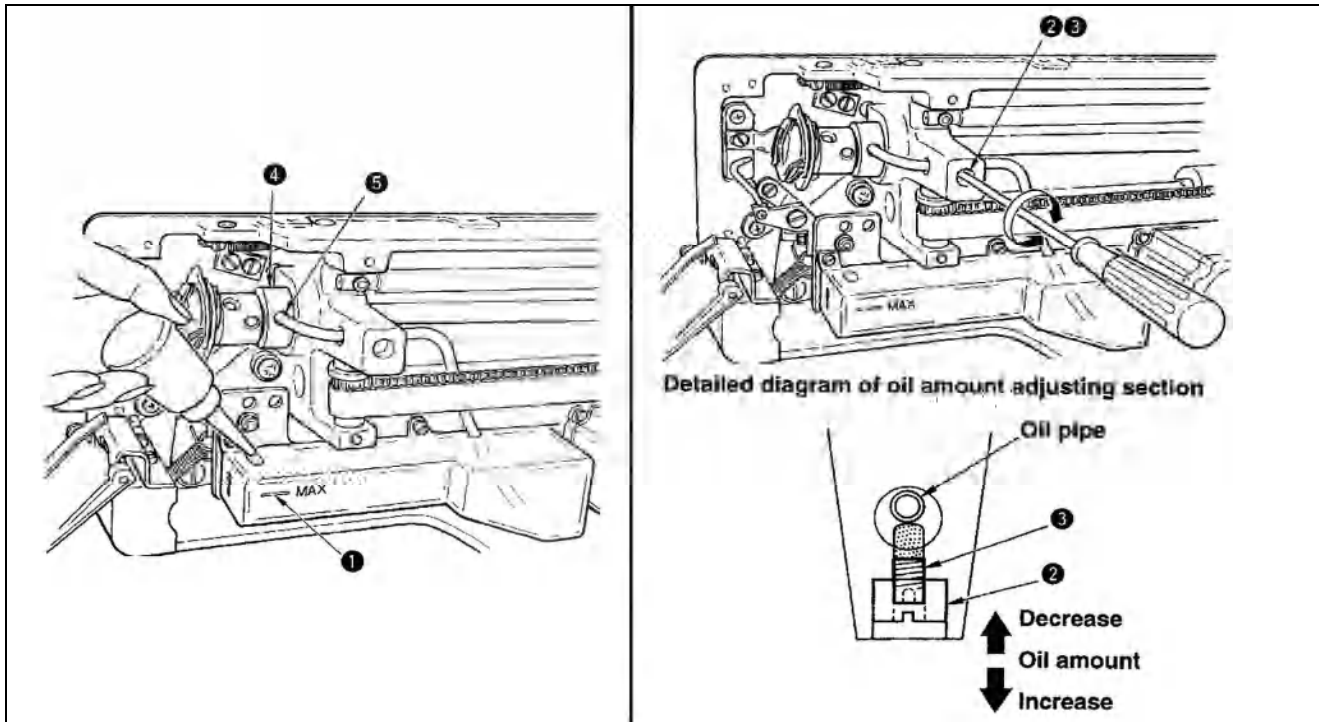

1) Lubricating oil to oiling tank

- Fill the oiling tank with New Delrix Oil No.1 up to the level indicated by "MAX" ❶.

2) Adjusting the lubrication for the sewing hook

- Adjust the amount of oil supplied to the sewing hook by loosening lock nut ❷ and turning oil amount adjusting screw ❸.
- Amount of supplied oil is reduced when turning the screws ❸ clockwise.
- Fix the screw with lock nut ❷ after adjusting the lubrication for the sewing hook.
- When you first operate your sewing machine after set-up or after an extended period of disuse, remove the bobbin case and apply a few drops of oil to the hook race. In addition, apply a few drops oil from oiling hole ❺ in hook driving shaft front metal ❹ to soak the inside felt in oil.

4-2.Inserting the needle



WARNING :

To protect against possible personal injury due to abrupt start of the machine, be sure to start the following work after turning the power off and ascertaining that the motor is at rest.

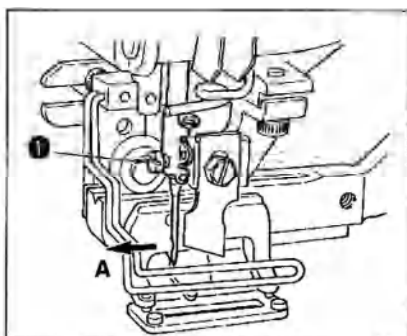

Hold needle with its recessed part facing toward the operator side A, insert the needle fully into the needle clamping hole, and tighten needle setscrew ❶. Use a DPx5-(#11J, #14J),



When attaching the needle, turn OFF the power to the motor.

4. PREPARATION BEFORE OPERATION

4-3. Threading the needle-thread



WARNING :

To protect against possible personal injury due to abrupt start of the machine, be sure to start the following work after turning the power off and ascertaining that the motor is at rest.

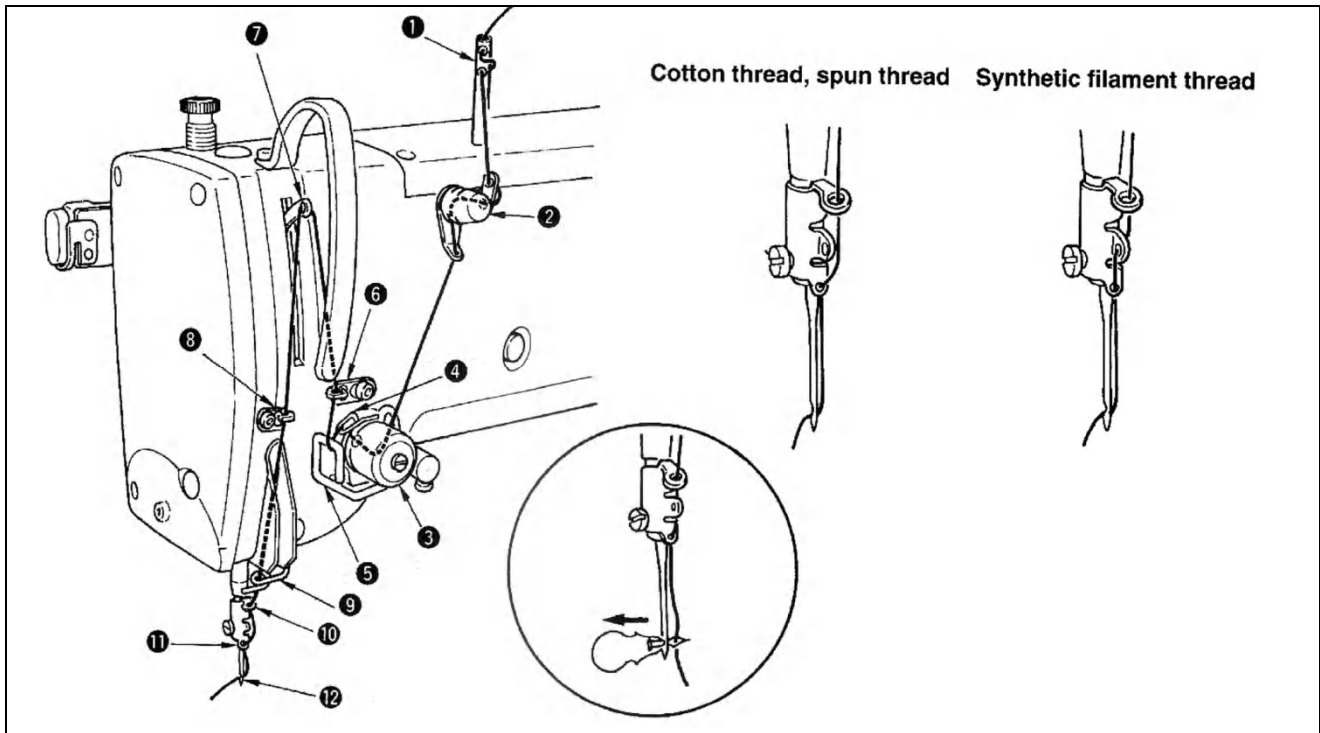

Pass the needle thread in the order ① to ⑫ as shown in the figures.
The threading can be done easily by using the needle threader supplied with the machine.
Change the thread guide threading method according to the thread to be used.

4-4. Threading the bobbin case

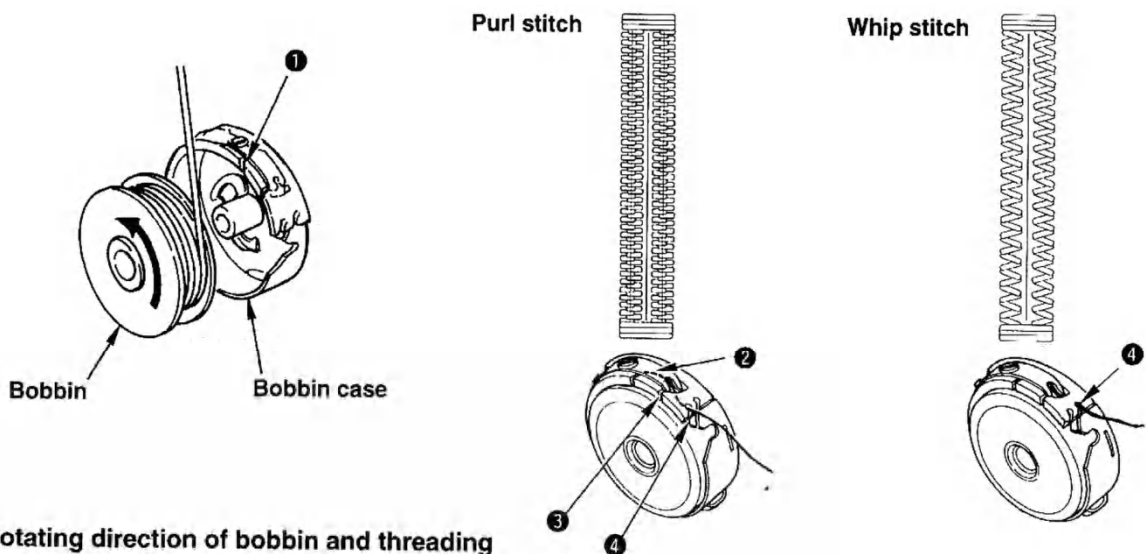

Rotating direction of bobbin and threading

- 1) Fit the bobbin so that it rotates in the direction of the arrow.
- 2) Pass the thread through thread slit ①, then through under the tension spring ②, again through thread slit ③, and pull the thread from ④.
- 3) Threading at ④ for purl stitching is different from that for whip stitching. So, be careful.

4-5.Adjusting the bobbin thread tension

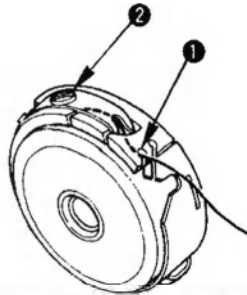

Adjust the bobbin thread tension as given below when the bobbin thread is pulled up at the position where thread slit ① of bobbin case comes up.

Purl stitch	0.05 to 0.15N	To such an extent that bobbin case quietly comes down when holding thread end coming from bobbin case and shaking it quietly up and down.
Whip stitch	0.15 to 0.3N	To such an extent that bobbin case barely comes down when holding thread end coming from bobbin case and shaking it somewhat strongly.

Turning tension adjust screw ② clockwise will increase bobbin thread tension, and turning it counterclockwise will decrease the tension.

Adjust the bobbin thread tension to lower for synthetic filament thread, and to higher for spun thread. The thread tension is higher by approximately 0.05N when the bobbin case is set to the hook since idle-prevention spring is provided.

 When bobbin thread tension is adjusted, check the needle thread tension setting of the memory switch. (See P.44.)

4-6.Installation of bobbin case

 **WARNING :** To protect against possible personal injury due to abrupt start of the machine, be sure to start the following work after turning the power off and ascertaining that the motor is at rest.

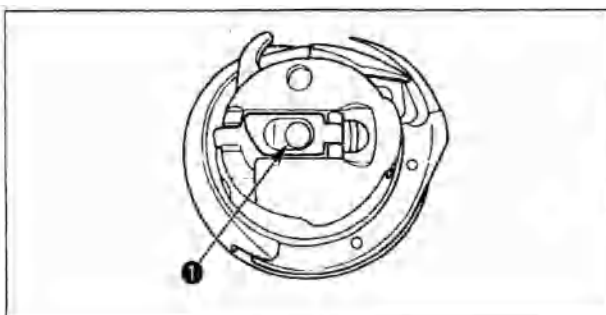

- 1) Lift up and hold bobbin case latch lever between two fingers.
- 2) Push the bobbin case into the hook so that it is supported by the hook shaft ① and then snap in the latch lever.
Press the bobbin case until the predetermined position is reached, and it will click.

 1. If the bobbin case is out of the predetermined position, it can jump out from the hook to cause the needle thread to tangle on the hook shaft. Check to be sure that the bobbin case is properly installed in the correct position.

2. There is a difference in the shape of bobbin case between the standard hook and the dry one. They have nothing in common with each other.

4. PREPARATION BEFORE OPERATION

4-7. Installing the knife



WARNING :

To protect against possible personal injury due to abrupt start of the machine, be sure to start the following work after turning the power off and ascertaining that the motor is at rest.

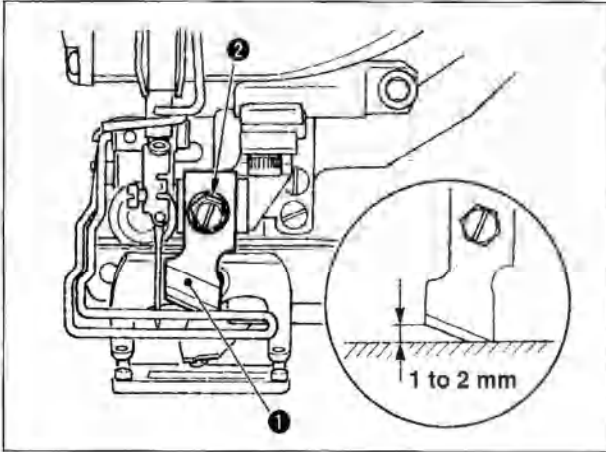

When replacing the knife with a new one, perform as follows.

- 1) Knife ① can be easily removed together with the washer when removing knife retaining screw ②.
- 2) Adjust so that the knife, when lowered the knife bar by hand, is spaced 1 to 2 mm away from the top surface of the throat plate as illustrated in the sketch. Then, be sure to place the washer and tighten the knife retaining screw.

Inch → mm CONVERSION TABLE

Knife size	Indication of mm
1/4	6.40
3/8	9.50
7/16	11.10
1/2	12.70
9/16	14.30
5/8	15.90
11/16	17.50
3/4	19.10
13/16	20.60
7/8	22.20
1	25.40
1 1/8	28.60
1 1/4	31.80
1 3/8	34.90
1 1/2	38.10

When the cloth cutting knife you have is indicated in inch, set the cloth cutting length (knife size) in mm using the inch → mm conversion table. (See P.29.)





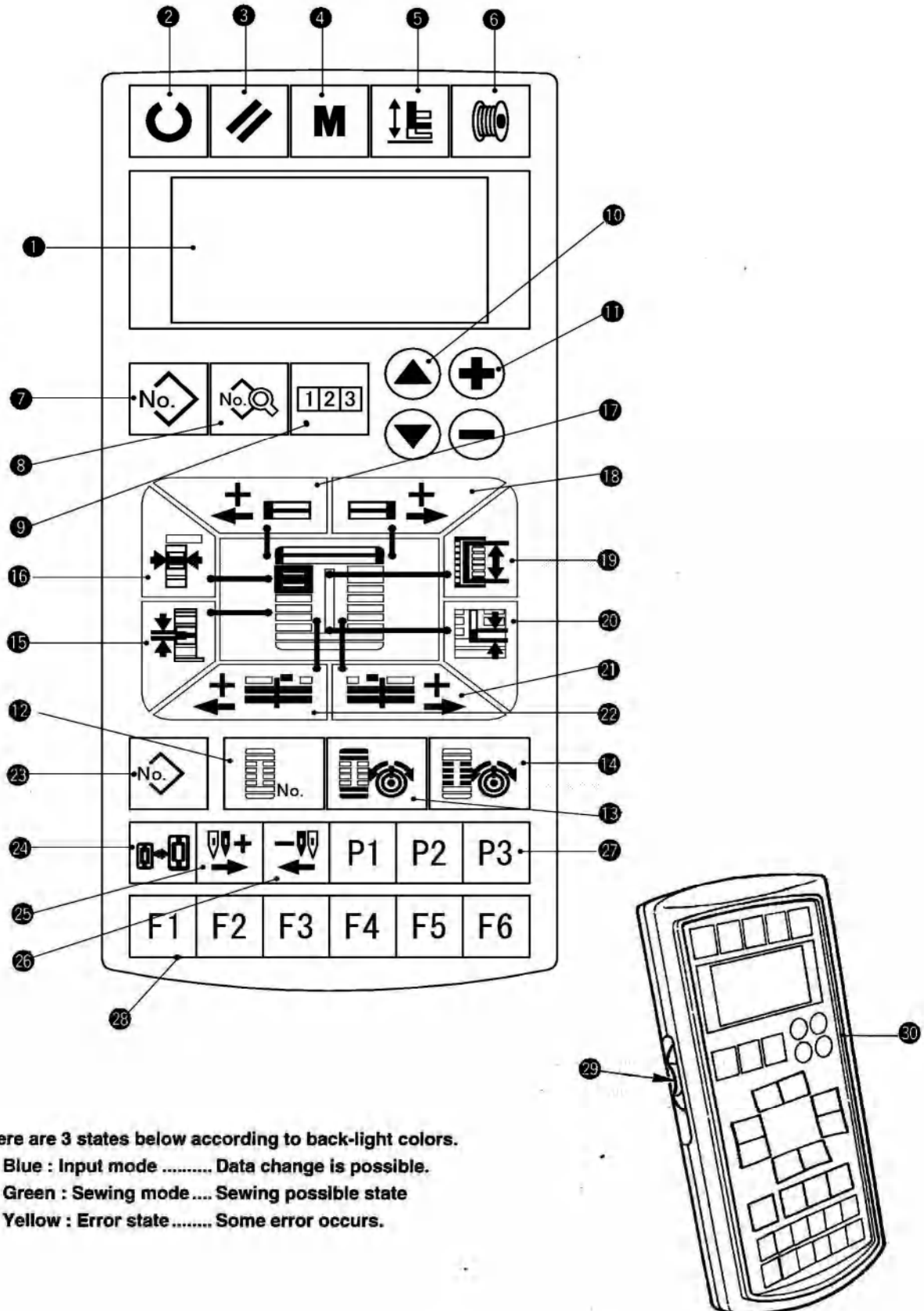





















5、 OPERATION OF THE SEWING MACHINE

5-1.Explanation of the operation panel switch

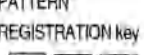

There are 3 states below according to back-light colors.
 Blue : Input mode Data change is possible.
 Green : Sewing mode Sewing possible state
 Yellow : Error state Some error occurs.

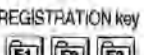
5. OPERATION OF THE SEWING MACHINE

No.	NAME	FUNCTION	No.	NAME	FUNCTION
1	LCD display	Various data such as pattern No., shape, etc. are displayed.	16	OVEREDGING WIDTH key 	This key selects overedging width display.
2	READY key 	Press this key when starting sewing. Every time this key is pressed, change-over of sewing ready set state and data set state can be performed.	17	BAR-TACKING WIDTH, LEFT key 	This key selects left side of bar-tacking width compensation display.
3	RESET key 	Press this key when releasing error, travelling the feed mechanism to its initial position, counter resetting, etc.	18	BAR-TACKING WIDTH, RIGHT key 	This key selects right side of bar-tacking width compensation display.
4	MODE key 	Press this key when changing data of the memory switches.	19	CLOTH CUT LENGTH key 	This key selects cloth cut length display.
5	PRESSER key 	This key lifts or lowers the presser. When the presser goes up, the needle bar travels to the origin and when it comes down, the needle bar travels to the right.	20	CLEARANCE key 	This key selects clearance display.
6	WINDER key 	This key is pressed when performing bobbin winding.	21	KNIFE GROOVE WIDTH, RIGHT key 	This key selects knife groove width, right compensation display.
7	PATTERN NO. key 	This key selects pattern No. display.	22	KNIFE GROOVE WIDTH, LEFT key 	This key selects knife groove width, left compensation display.
8	DATA key 	This key selects data display.	23	COPY key 	Press this key when copying pattern.
9	COUNTER key 	Thus key selects counter display.	24	PRESSER SELECTION key 	This key selects presser type.
10	ITEM SELECTION key 	This key selects pattern No., data No., etc.	25	FORWARD key 	This key makes the feed mechanism travel forward stitch by stitch.
11	DATA CHANGE key 	This key changes various data.	26	BACKWARD key 	This key makes the feed mechanism travel backward stitch by stitch.
12	SHAPE key 	This key selects shape display.	27	PATTERN REGISTRATION key 	This is a short cut key that pattern registration is available. Registration of shortcut to setting display of an optional pattern is possible. For the setting procedure, see P.36.
13	THREAD TENSION AT PARALLEL SECTION key 	This key selects thread tension at parallel section display.	28	PARAMETER REGISTRATION key 	This is a short cut key that parameter registration is available. Registration of shortcut to setting display of an optional pattern, sewing parameter or adjustment data is possible. For the setting procedure, see P.37
14	THREAD TENSION AT BAR-TACKING SECTION key 	This key selects thread tension at bar-tacking section display.	29	Speed variable resistor	Speed increases when this is lifted upward and decreases when this is lowered downward.
15	PITCH key 	This key selects pitch of parallel section.	30	LCD adjustment variable resistor	Light and shade of LCD display can be adjusted.

5-2. Basic operation of the sewing machine

1) Turn ON the power switch.

First, check that presser type A which has been set is the same as that of the presser actually mounted. For checking and setting procedures, refer to 4. **Inputting the presser type.**

2) Select the pattern No. you desire to sew.

When the power is turned ON, the pattern No. B which is selected at present flashes on and off. When you desire to change it, press ITEM SELECTION key ⑩ (▲▼) and select the No. you desire to sew. When you purchase the sewing machine, pattern No. 1 to 10 described in 11. **Changing sewing data** have been registered. Select the pattern No. you desire to sew from among these numbers. (The No. with which the pattern has not been registered is not displayed.)

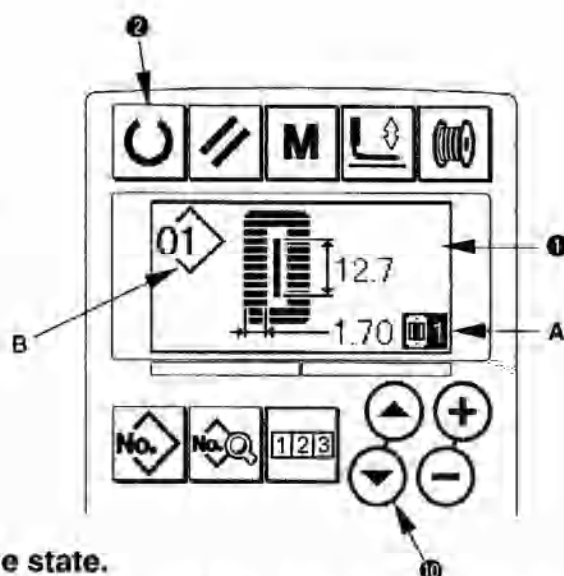

3) Set the sewing machine to sewing possible state.

Press READY key ② (U) and the back-light of LCD display ① changes from blue color to green color, and sewing is possible.

4) Start sewing.

Set the sewing product to the presser portion, and operate the pedal to start the sewing machine, and sewing starts. When you purchase the sewing machine, 2-pedal type has been set. However, pedal operating procedure can be selected from among three ones. Select the operating procedure you desire and use the sewing machine. → 3. **How to use the pedal.**

5-3. How to use the pedal

This sewing machine can be used by selecting the pedal operating procedure from among 3 types below. Select the operating procedure you desire for working efficiency and use the sewing machine.

(1) Setting procedure of the pedal type

1) Call the pedal type setting parameter.

Press MODE key ④ (M) for as long as three seconds in the state of the input mode and memory switch (level 2) edit screen A is displayed. When the pedal type selection parameter **K01** is not displayed, press ITEM SELECTION key ⑩ (▲▼) to select the pedal type.

2) Select the pedal type

Press DATA CHANGE key ⑪ (▲▼) and the picture is changed as shown in the illustration below. Select the pedal type B you desire.

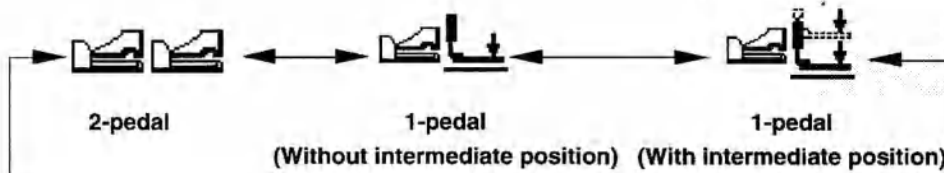
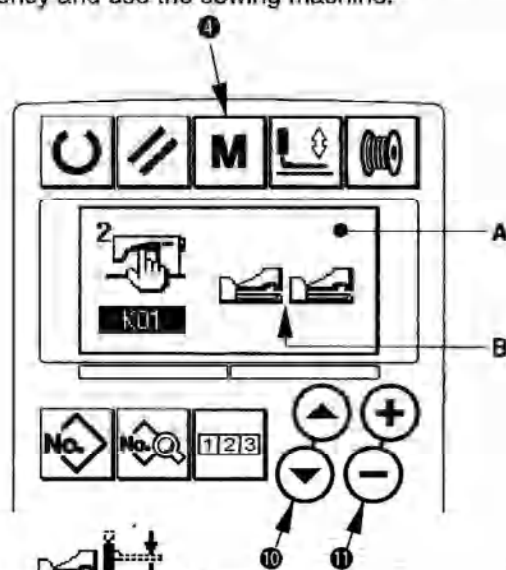

5. OPERATION OF THE SEWING MACHINE

(2)Explanation of pedal motion

<u>2-pedal type</u>	<u>1-pedal</u> <u>(Without intermediate position)</u>	<u>1-pedal</u> <u>(With intermediate position)</u>
<p>Initial position Presser : <u>Intermediate position ②</u> or <u>Sewing position ③</u></p> <p>1) Setting of sewing product (Presser goes up as high as the pedal toe down amount of the left side pedal.)</p> <p>2) Start of Sewing (Sewing starts when the right side pedal is depressed.)</p> <p>3) End of sewing (Presser automatically goes up to <u>Intermediate position ②</u>.)</p>	<p>Initial position Presser : <u>Maximum position ①</u></p> <p>1) Setting of sewing product</p> <p>2) Confirmation of setting of sewing product (Presser comes down to <u>Cloth setting position ③</u> when the first step of the right side pedal is depressed.)</p> <p>3) Start of sewing (Sewing starts when the second step of the right side pedal is depressed.)</p> <p>4) End of sewing (Presser automatically goes up to <u>Maximum position ①</u>)</p>	<p>Initial position Presser : <u>Maximum position ①</u></p> <p>1) Setting of sewing product</p> <p>2) Confirmation of setting of sewing product (Presser comes down to <u>Intermediate position ②</u> when the first step of the right side pedal is depressed.)</p> <p>3) Confirmation of start of sewing (Presser comes down to <u>Cloth setting position ③</u> when the second step of the right side pedal is depressed.)</p> <p>4) Start of sewing (Sewing starts when the third step of the right side pedal is depressed.)</p> <p>5) End of sewing (Presser automatically goes up to <u>Maximum position ①</u>.)</p>

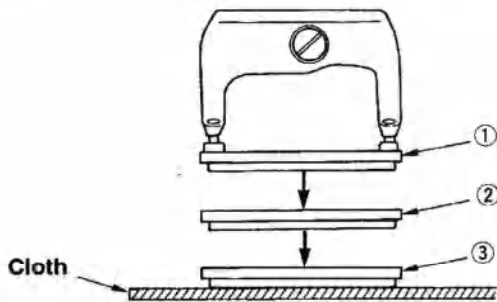

* Height of the respective positions of ① to ③ described on the left side can be set or changed by the memory switches.

→ 20. Method of changing memory switch data

• Pedal switch setting

Attach or remove the screw shown in the figure according to the setting of the memory switch.

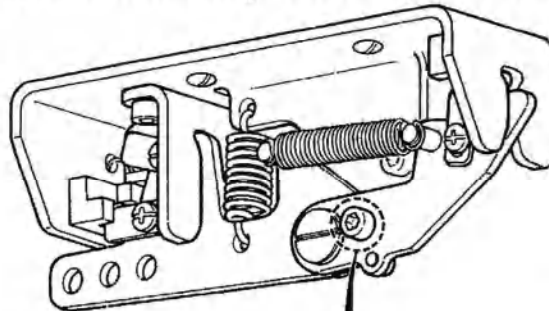

• 2-pedal type

• 1-pedal (Without intermediate position)

Remove the screw.

Attach the screw.

• 1-pedal (With intermediate position)



5-4. Input of the presser type

(1) Setting procedure of the presser type

1) Call the presser type setting parameter.

Press PRESSER SELECTION key  and memory switch (level 1) edit screen A is displayed.



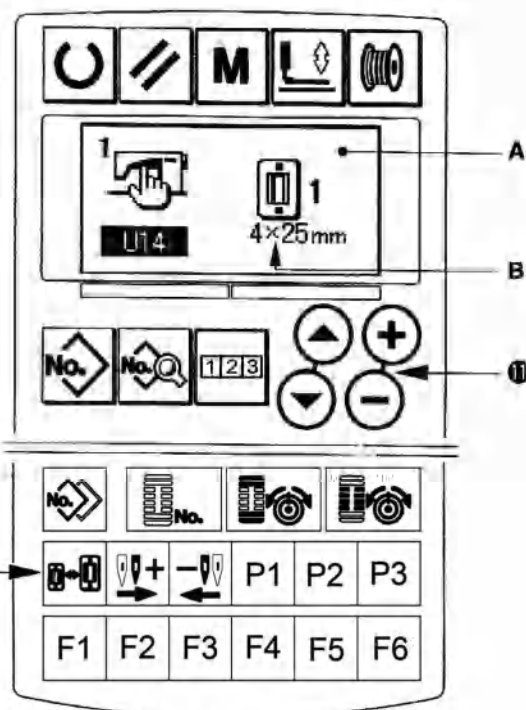
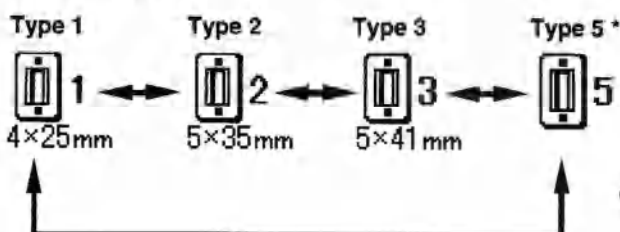

2) Select the presser type.

Press DATA CHANGE key   , and the picture is changed as shown in the illustration below. Set the presser type B actually mounted on the sewing machine referring to **Table of presser type** below.



(2) Table of presser type

Set the number in the frame of engraved part number of presser to the type of presser.

	Type	Part No. of presser foot •
 4×25mm	Type 1	CS0151177 1 000 *
 5×35mm	Type 2	CS0151177 2 000 *
 5×41mm	Type 3	CS0151177 3 000 *
 5×41mm	Type 5 *	

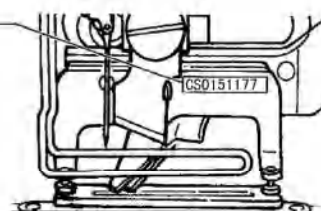

* Set type 5 when using the presser other than type 1 to 3. Change U15 Presser size width and U16 Presser size length of the memory switch (level 1) to adjust to the presser to be used.

→ Refer to 20. **Method of changing memory switch data.**

* When using type 5 with stitch width of 6 mm or more and 41 mm or more in length, it is necessary to replace components such as presser arm, feed plate, etc.

5-5. Performing pattern selection

(1) Selection from the pattern selection screen

1) Set the mode to the input mode.

When the back-light of LCD display ❶ shows the input mode in blue color, it is possible to change the pattern. When the back-light shows the sewing mode in green color, press READY key ❷  to change over to the input mode.

2) Call the pattern selection screen.

Press PATTERN No. key ❸ , and pattern selection screen A is displayed.

Pattern No. B which is selected at present flashes on and off.

3) Select the pattern.

Press ITEM SELECTION key ❹ , and the patterns which have been registered are changed over in order and displayed. Here, select the No. you desire to sew.

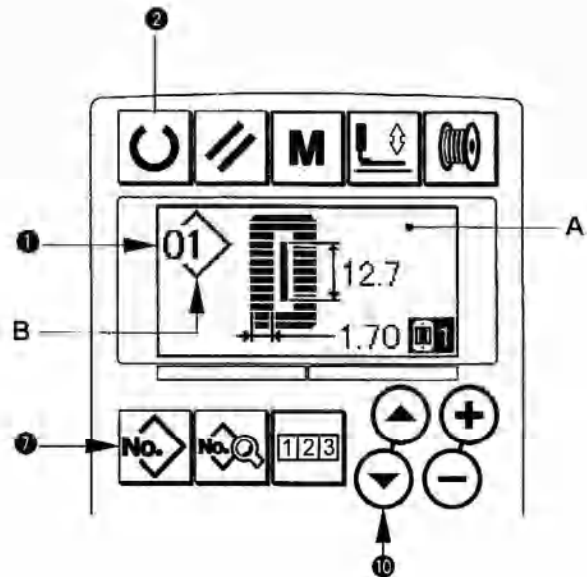

(2) Selection by means of the register key

This sewing machine can register the pattern No. you desire with the register switch. When the pattern is registered once, pattern selection can be performed by pressing only the switch.

→ Refer to 15. Using pattern register key.



5-6.Changing needle thread tension

Needle thread tension can be changed while performing trial sewing since the data related to the needle thread tension can be set by the sewing mode as well.

1) Call thread tension at parallel section setting data.

Press THREAD TENSION AT PARALLEL SECTION key **13** , and sewing data edit screen A is displayed.



2) Change thread tension at parallel section.

Press DATA CHANGE key **11**  **+**  **-**, and set value B goes up or comes down and the thread tension can be changed. The relation between the finish of sewing and the set value is as shown in the illustration below. Set the value referring to the illustration.

3) Call thread tension at bar-tacking section setting data.

Press THREAD TENSION OF BAR-TACKING SECTION key **14** , and sewing data edit screen C is displayed.

4) Changing the needle thread tension at bar-tacking section

Press DATA CHANGE key **11**  **+**  **-**, and set value D goes up or comes down and the thread tension can be changed. The relation between the finish of sewing and the set value is as shown in table below. Set the value referring to the table.

* For the tension other than that at parallel section and bar-tacking section, refer to **11. Changing sewing data** and **20. Method of changing memory switch data**.

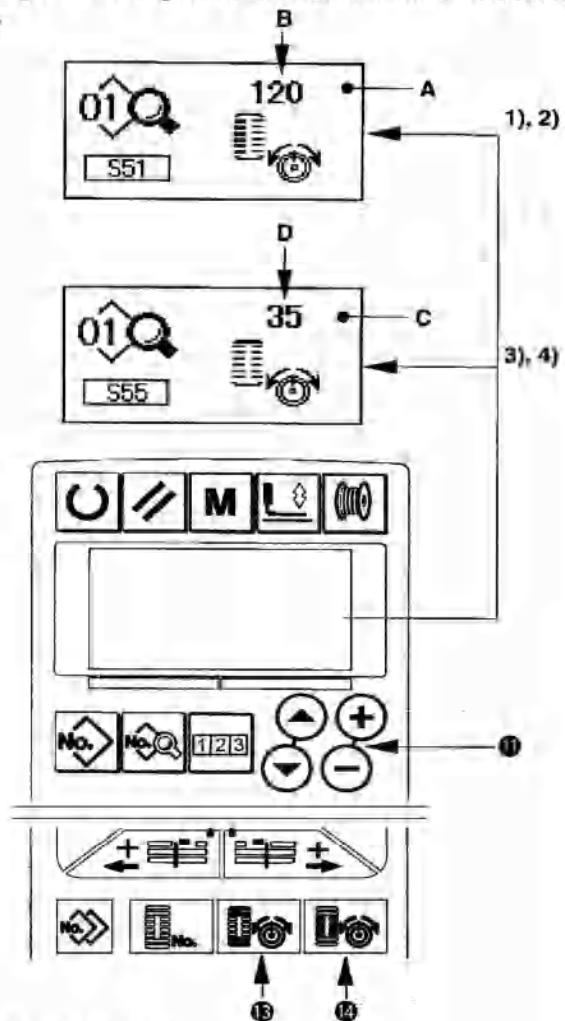



Set value of tension at ① parallel section and ② bar-tacking section

	Set value on panel			
		-	Initial value	+
Purl stitch	① Tension at parallel section	Crest is lowered.	120	Crest is raised.
	② Bar-tacking tension	Thread tension is decreased.	35	Thread tension is increased.
Whip stitch	① Tension at parallel section	Thread tension is decreased.	60	Thread tension is increased.
	② Bar-tacking tension	Thread tension is decreased.	60	Thread tension is increased.

For the eyelet radial shape, set the bar-tacking tension first to approximately 120 and make the balance of stitches.

Purl stitch and Whip stitch

	Purl stitch	Purl stitch When applying higher tension to the needle thread to permit it to pass straight through fabric, the purl stitch is formed by the bobbin thread which is pulled over from both sides to the center line.
	Whip stitch	Whip stitch The whip stitch is formed in zigzag showing the needle thread only on top of fabric, and the bobbin thread on the bottom.

5-7. Performing re-sewing

When stop switch A is pressed during sewing operation, the sewing machine interrupts sewing and stops. At this time, error display screen B is displayed to inform that the stop switch is pressed.

To continue performing sewing from some point in sewing

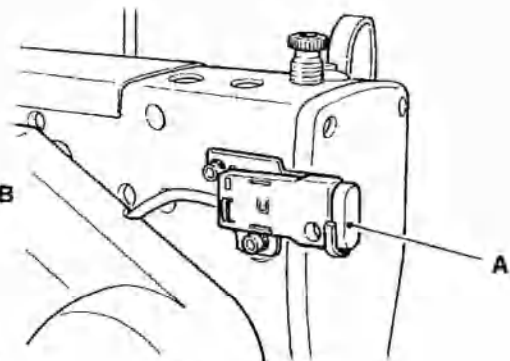
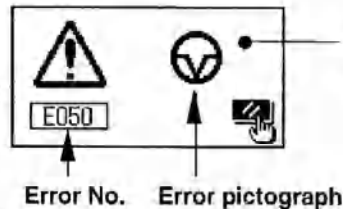

Sewing motion stop status

Error display screen B is displayed.

1) Release the error.

Press RESET key ③  to release the error. Then step motion screen C is displayed.

2) Return the presser.

Press BACKWARD key ②⑥  and the presser returns stitch by stitch.

Press FORWARD key ②⑤  and the presser advances stitch by stitch. Return the presser to the re-sewing position.

3) Start sewing again.

Depress the right side pedal and sewing starts again.

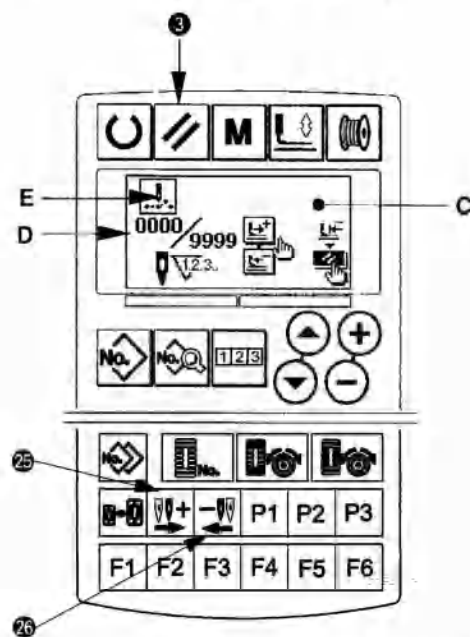

To perform re-sewing from the start

Sewing motion stop status

Error display screen B is displayed.

1) Release the error.

Press RESET key ③  to release the error. Then step motion screen C is displayed.

2) Return the presser to the sewing product setting position.

Press again RESET key ③  and the presser returns to the sewing product setting position.

3) Perform again the sewing work from the start.

* Existing number of stitches/total number of stitches are displayed in section D.

* Existing sewing command is displayed in section E.

Kinds of commands are :

Sewing command



Jump feed command



Thread trimmer command



Knife command



5-8.Winding bobbin thread

(1) Winding the bobbin

1) Set the bobbin .

Fit a bobbin fully onto the bobbin winder shaft. Take the thread from the spool and pass it through the guides in the numerical order as shown in the figure, and wind the end of the thread several times around the bobbin. Then push the bobbin winder trip latch ① in the direction of the arrow mark.

2) Set the mode to the bobbin winding mode.

Press WINDER key ⑥  from either input status or sewing status to enter the bobbin winding mode, and bobbin winding screen C is displayed.

3) Start bobbin winding.

Depress the right-hand side pedal, and the sewing machine rotates and starts winding bobbin thread.

4) Stop the sewing machine.

Once the bobbin is wound with the predetermined amount of thread, bobbin thread guide ① is released. Press WINDER key ⑥  or depress the right-hand side pedal to stop the sewing machine. Then remove the bobbin and cut bobbin thread with thread trimmer retaining plate ④ .

- Press WINDER key ⑥  , and the sewing machine stops and returns to the normal mode.
- Depress the right-hand side pedal and the sewing machine stops while the bobbin thread winding mode stays as it is. Use this way when winding bobbin thread around plural bobbins.

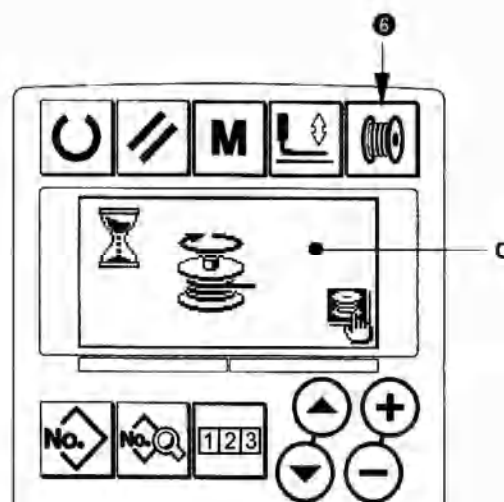
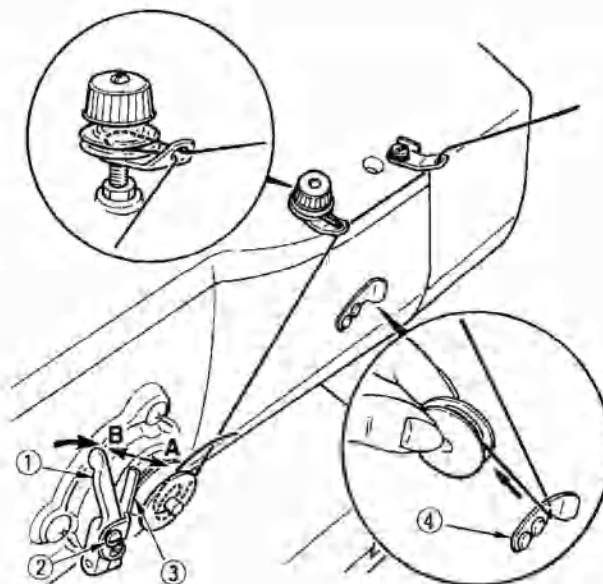

(2) Adjusting the amount to be wound on a bobbin

To adjust the winding amount of the bobbin thread, loosen the setscrew ② and move the bobbin winder adjusting plate ③ to the direction of A or B. Then, tighten the setscrew ② .



To the direction of A : Decrease

To the direction of B : Increase

5-9.Using the counter



(1) Setting procedure of the counter value

1) Call counter setting screen.

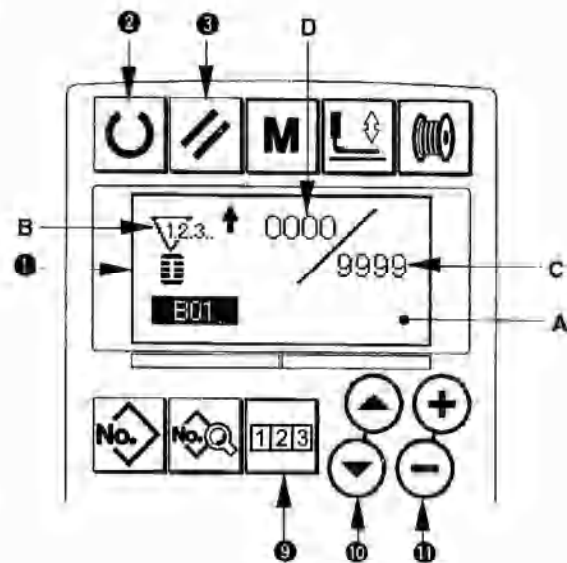

Press COUNTER key ⑨  under the input mode, and counter screen A is displayed. Then setting is possible. Setting of the counter value can be performed only with the input mode (back-light of LCD display ① is blue). In case of the sewing mode (back-light of LCD display ① is green), press READY key ②  to set the mode to the input mode.





2) Selection of kinds of counters

Press ITEM SELECTION key ⑩  to make pictograph B showing the kind of counter flash on and off. Press DATA CHANGE key ⑪ , and select the counter you desire from among the kinds of counters below.

3) Change of counter set value

Press ITEM SELECTION key ⑩  to make counter set value C flash on and off. Press DATA CHANGE key ⑪  and input the set value until count-up is reached.

4) Change of existing counter value

Press ITEM SELECTION key ⑩  to make existing counter value D flash on and off. Press RESET key ③  and the value on the way of counting can be cleared. In addition, it is possible to edit the numerical value with DATA CHANGE key ⑪ .

(2) Kind of counter



① Sewing UP counter

Every time the sewing of one shape is performed, the existing value is counted up. When the existing value is equal to the set value, count-up screen is displayed.



② Sewing DOWN counter

Every time the sewing of one shape is performed, the existing value is counted down. When the existing value is reached to "0", count-up screen is displayed.



③ No. of pcs. UP counter

Every time one cycle or one continuous stitching is performed, the existing value is counted up. When the existing value is equal to the set value, count-up screen is displayed.



④ No. of pcs. DOWN counter

Every time one cycle or one continuous stitching is performed, the existing value is counted down. When the existing value is reached to "0", count-up screen is displayed.



⑤ Counter not used

(3) Count-up releasing procedure

When count-up condition is reached during sewing work, the whole count-up screen E flashes on and off. Press RESET key ③  to reset the counter, and the mode returns to the sewing mode. Then the counter starts counting again.

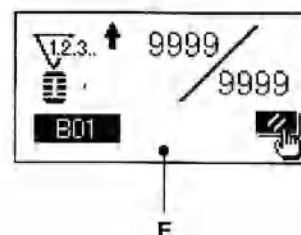

5-10. Using the initial value pattern

This sewing machine has the initial value to perform the optimum sewing for the sewing shapes (30 shapes).

• Refer to **XI**, **INITIAL VALUE DATA FOR EACH SHAPE TABLE**.

When creating sewing data newly, it is convenient to create it by copying the initial value pattern.

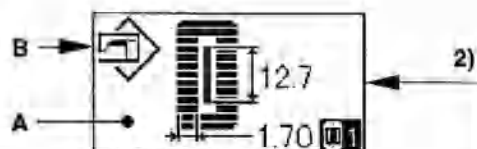

1) Set the mode to the input mode.

When the back-light of LCD display ① shows input mode in blue color, it is possible to change the pattern. When the back-light shows the sewing mode in green color, Press READY key ②  to change over to the input mode.





2) Call initial value pattern.

Press PATTERN NO. key ⑦ , and pattern selection screen A is displayed.

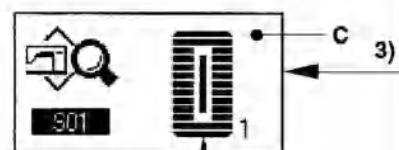
Pattern No. B which is selected at present flashes on and off on the display. Press ITEM SELECTION key ⑩  to select initial value pattern .



3) Select shape.

Press SHAPE key ⑫ , and shape selection screen C is displayed. Shape D which is selected at present flashes on and off on the display. Select shape D to sew with DATA CHANGE key ⑪  . It is possible to select the shape from among 12 shapes at the time of your purchase. However, it is possible to select the shape from among maximum 30 shapes by increasing the shape selection level (K04).

→ Refer to **20**, **Method of changing memory switch data**.

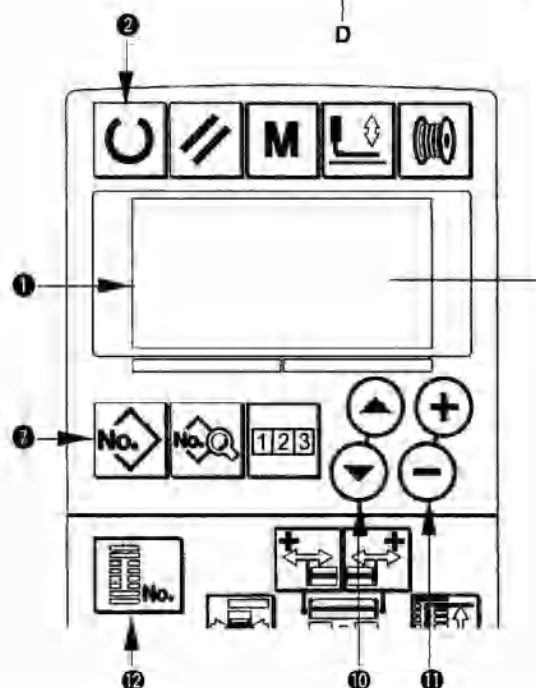

4) Perform trial sewing.

Press READY key ②  to set the mode to the sewing mode (back-light of LCD display ① is green). Then it is possible to perform sewing and the selected shape can be sewn.

* Initial value pattern can edit the needle thread tension data only. However, it returns to the initial value when changing the shape or performing re-call of the pattern. So, be careful.

5) Copy initial value pattern.

Copy the pattern which has been selected and confirmed through the steps above to the normal pattern and use it.

Copying procedure → Refer to **14**, **copying sewing pattern**.

5-11.Changing sewing data

(1) Initial sewing data at the time of your purchase

Patterns from 1 to 10 have been already registered at the time of your purchase. Initial values of the square type, the cloth cutting length of which only is different from each other, have been inputted in the sewing data. → Refer to **XI . INITIAL VALUE DATA FOR EACH SHAPE TABLE.**

Pattern No.	Cloth cutting length  S02
1	6.40mm (1/4")
2	9.50mm (3/8")
3	11.1mm (7/16")
4	12.7mm (1/2")
5	14.30mm (9/16")
6	15.90mm (5/8")
7	17.50mm (11/16")
8	19.10mm (3/4")
9	22.20mm (7/8")
10	25.40mm (1")

(2) Changing procedure of sewing data

1) Set the mode to the input mode.

When the back-light of LCD display **1** shows the input mode in blue color, it is possible to change the sewing mode.

When the back-light of shows the sewing mode in green color, press READY key **2**  to change over to the input mode.

2) Call sewing data edit screen.

Press DATA key **8** , and sewing data edit screen A of the pattern No. which is selected at present is displayed.

3) Select sewing data to be changed.

Press ITEM SELECTION key **10** , and select the data item you desire to change.

Data item which is not used according to the shape and data item which is set without function are skipped and not displayed. So, be careful.

→ Refer to **12. Method of setting sewing data with/without edit**

4) Change data.

For the sewing data, there are data item which changes numerical value and that which selects pictograph. No. such as S02 is attached to the data item which changes numerical value. Increase or decrease the set value with DATA CHANGE key **11**  to change the value.

No. such as S01 is attached to the data item which selects pictograph. Pictograph can be selected with DATA CHANGE key **11** .

→ For the details of sewing data, refer to **13. Sewing data table.**

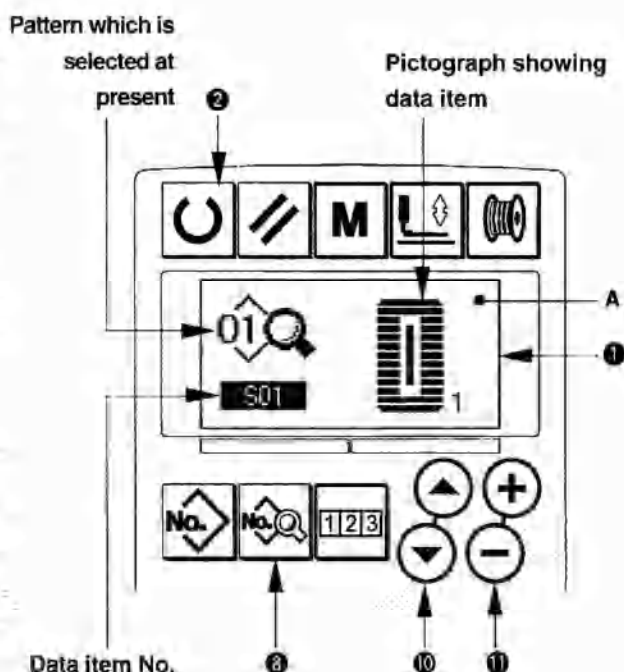

5-12. Method of setting sewing data with/without edit

This sewing machine has been set so as not to be capable of editing sewing data items which are less frequently used at the time of your purchase. When you desire to set the data more closely in accordance with the sewing products, set the sewing data item to the edit possible state and use the machine.

For the setting of sewing data with/without edit, when S52, right parallel section tension is set to without edit, sewing is performed with the data of S51 left parallel section tension. When S56, 2nd bar-tacking tension is set to without edit, sewing is performed with the data of S55, 1st bar-tacking section.

When the sewing data items other than the above ones are set to without edit, the data to be referred are the initial value data.



1) Set the mode to the input mode.

When the back-light of LCD display ① shows the input mode in blue color, it is possible to set. When the back-light shows the sewing mode in green color, press READY key ②  to change over to the input mode.



2) Call sewing data with/without edit changeover screen.

Press DATA key ③  for as long as three seconds, and data with/without edit changeover screen A or B is displayed.

3) Select sewing data you desire to change over.

Press ITEM SELECTION key ⑩  , and select sewing data item C you desire to change over. At this time, changeover possible item only can be selected.

4) Changeover of with/without edit

Press DATA CHANGE key ⑪  , and pictograph display C of sewing data repeats reverse/non-reverse.

Non-reverse display : With edit

Reverse display : Without edit

Return to step 3), and plural sewing data items can be changed over.

5) Save data which have been set.

Press READY key ② , and the data in the state of being changed over can be saved. After two seconds, the screen returns to the former one.

Press RESET key ⑤ , and the screen returns to the former one without saving the data.

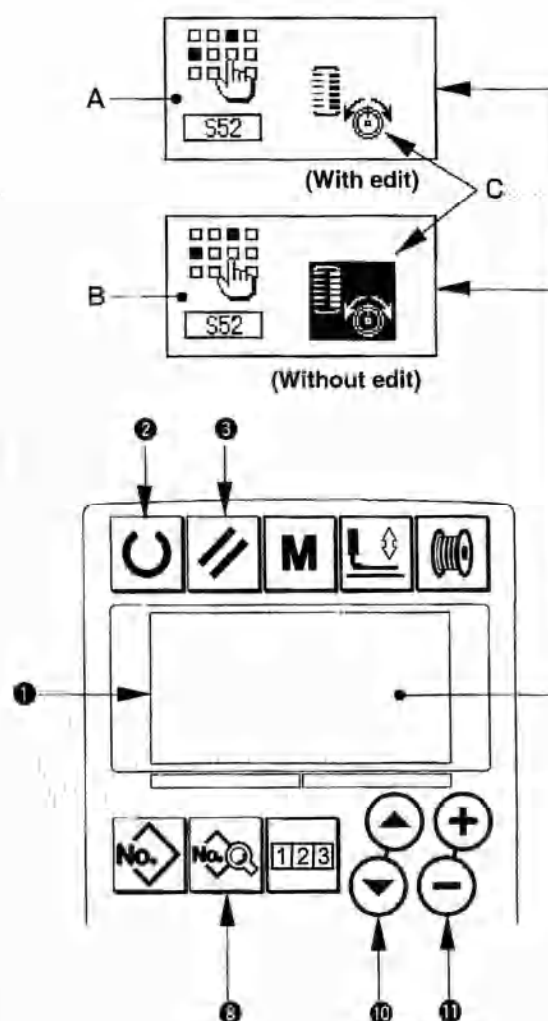

5. OPERATION OF THE SEWING MACHINE

5-13.Sewing data list

☆ Sewing data are those that can be inputted to 99 patterns from pattern 1 to 99 and can be inputted to each pattern. The sewing machine has been set in the state that the data which is necessary to set "With/without edit" cannot be selected at the time of your purchase. Change over the function to "With edit" if necessary for the use. → Refer to **5-12. Method of setting sewing data with/without edit.**

No.	Item	Setting range	Edit unit	Remarks
S01	<p>Sewing shape</p> <p>This item selects the shape from among the sewing shapes of 30 different kinds which the sewing machine has.</p> <p>Refer to II -3. Standard sewing shape list.</p> <p>* Only 12 kinds of standard sewing shapes can be selected at the time of your purchase. When increasing the kinds of shapes, perform setting of K04 Sewing shape selection level of memory switch data. → Refer to 21. Memory switch list.</p>	1 to 30	1	—
S02	<p>Cloth cut length</p> <p>This item sets the length of cloth that is cut by cloth cutting knife. However, in case of bar-tack shape (Nos. 27, 28, 29, and 30 of S01), sewing length is set.</p> <p>By making effective U19 Function of plural motions of cloth cutting knife of memory switch data, make the plural motions of knife by the knife size set in the item U18 Cloth cutting knife size, and the sewing product is cut. → Refer to 21. Memory switch list.</p>	3.0 to 120.0	0.1mm	—
S03	<p>Knife groove width, right</p> <p>This item sets the clearance between cloth cutting knife and right parallel section.</p>	-2.00 to 2.00	0.05mm	—
S04	<p>Knife groove width, left</p> <p>This item sets the clearance between cloth cutting knife and left parallel section.</p>	-2.00 to 2.00	0.05mm	—
S05	<p>Overedging width, left</p> <p>This item sets the overedging width of left parallel section.</p>	0.10 to 5.00	0.05mm	—
S06	<p>Ratio of right and left shapes</p> <p>This item sets enlargement/reduction ratio of right side shape making the knife position as the center.</p>	50 to 150	1%	→
S07	<p>Pitch at parallel section</p> <p>This item sets sewing pitch of left and right parallel sections.</p>	0.200 to 2.500	0.025mm	—
S08	<p>2nd bar-tacking length</p> <p>This item sets length of bar-tacking on the front side.</p> <p>Bottom of square type Bottom of straight bar-tacking Bottom of taper </p>	0.2 to 5.0	0.1mm	—
S09	<p>1st bar-tacking length</p> <p>This item sets length of bar-tacking on the rear side.</p> <p>Top of square type </p>	0.2 to 5.0	0.1mm	—

* 1 : Displayed according to the shape











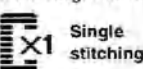
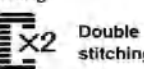
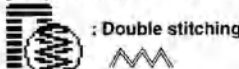
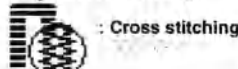

* 2 : Displayed when it is set to with edit. Refer to 12. Method of setting sewing data with/without edit.

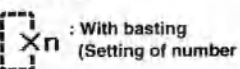
* 3 : Displayed when the function is selected.















5. OPERATION OF THE SEWING MACHINE

No.	Item	Setting range	Edit unit	Remarks
S10	Compensation of bar-tacking width, right This item adjusts right side outer shape of bar-tacking section in terms of overedging section. 	-1.00 to 1.00	0.05mm	—
S11	Compensation of bar-tacking width, left This item adjusts left side outer shape of bar-tacking section in terms of overedging section. 	-1.00 to 1.00	0.05mm	—
S12	Taper bar-tacking offset, left This item sets length to form bar-tacking section of taper bar-tacking shape. 	0.00 to 3.00	0.05mm	*1
S13	Taper bar-tacking offset, right This item sets length to form bar-tacking section of taper bar-tacking shape. 	0.00 to 3.00	0.05mm	*1
S14	Eyelet shape length This item sets upper side length from center of eyelet of eyelet shape. 	1.0 to 10.0	0.1mm	*1
S15	Number of stitches of eyelet shape This item sets number of stitches in the upper 90° of eyelet shape. 	1 to 8	1	*1
S16	Eyelet width This item sets crosswise size of the inside of eyelet shape. Actual needle entry point is the dimension to which S04 Knife groove width, left is added. 	1.0 to 10.0	0.1mm	*1
S17	Eyelet length This item sets lengthwise size of the inside of eyelet shape. 	1.0 to 10.0	0.1mm	*1
S18	Round type shape length This item sets upper length from the center of round type shape. 	1.0 to 5.0	0.1mm	*1
S19	Number of stitches of radial shape This item sets number of stitches in the upper 90° of radial shape. 	1 to 8	1	*1
S20	Reinforcement of radial shape This item sets with/without reinforcement stitching of radial shape. 	—	—	*1, *2
S21	Pitch at bar-tacking section This item sets sewing pitch of bar-tacking section. 	0.200 to 2.500	0.025mm	—













5. OPERATION OF THE SEWING MACHINE









NO.	Item	Setting range	Edit unit	Remarks
S22	1st clearance This item sets the clearance between 1st bar-tacking and knife groove. This item is applied to all shapes. 	0.0 to 4.0	0.1mm	-
S23	2nd clearance This item sets the clearance between 2nd bar-tacking and knife groove. This item is applied to all shapes. 	0.0 to 4.0	0.1mm	-
S31	Single/double stitching This item selects single or double stitching.  	-	-	-
S32	Double stitching cross selection This item selects overlapping stitching or cross stitching at the needle entry of parallel section when setting double stitching.  : Double stitching  : Cross stitching	-	-	*3
S33	Compensation of double stitching width This item sets amount to narrow overedging width of 1st cycle when setting double stitching. 	0.0 to 2.0	0.1mm	*3
S34	Number of times of basting This item sets number of times of basting.  : Without basting  : With basting (Setting of number of times)	0 to 9	1 time	-
S35	Basting pitch This item sets pitch at the time of performing basting. 	1.0 to 5.0	0.1mm	*3
S36	Rolling length of basting This item sets rolling length of needle thread when performing basting. 	2.0 to 20.0	0.1mm	*3
S37	Rolling pitch of basting This item sets rolling pitch of needle thread when performing basting. 	0.2 to 5.0	0.1mm	*3
S38	Rolling width of basting This item sets rolling width of needle thread when performing basting. 	0.0 to 4.0	0.1mm	*3
S39	Lengthwise compensation of needle entry of basting This item sets the amount to move needle entry position back and forth when performing basting more than two cycles. 	0.0 to 2.5	0.1mm	*2, *3
S40	Crosswise compensation of needle entry of basting This item sets the amount to move needle entry position to the right or left when performing basting more than two cycles. 	0.0 to 1.0	0.1mm	*3
S41	Compensation of left side position of basting This item sets the amount to move the sewing reference position of basting from the center of left overedging to the right or left. 	-2.0 to 2.0	0.1mm	*2, *3

5. OPERATION OF THE SEWING MACHINE

NO.	Item	Setting range	Edit unit	Remarks
S42	Compensation of right side position of basting This item sets the amount to move the sewing reference position of basting from the center of right overedging to the right or left. 	-2.0 to 2.0	0.1mm	*2, *3
S44	Speed setting of basting This item sets speed of basting. 	400 to 4200	100rpm	*3
S45	Sewing together function This item selects the function when performing sewing together first.  : Without sewing together  : With sewing together When "With sewing together" is selected : Sewing is performed in the order of sewing together → basting → normal sewing.	-	-	-
S46	Width of sewing together This item sets sewing width when performing sewing together. 	1.0 to 10.0	0.1mm	*2, *3
S47	Pitch of sewing together This item sets sewing pitch when performing sewing together. 	0.2 to 5.0	0.1mm	*2, *3
S51	Left parallel section tension This item sets needle thread tension at left parallel section. 	0 to 200	1	-
S52	Right parallel section tension This item sets needle thread tension at right parallel section. 	0 to 200	1	*2
S53	Left parallel section tension (1st cycle of double stitching) This item sets needle thread tension at left parallel section of 1st cycle at the time of double stitching. 	0 to 200	1	*2, *3
S54	Right parallel section tension (1st cycle of double stitching) This item sets needle thread tension at right parallel section of 1st cycle at the time of double stitching. 	0 to 200	1	*2, *3
S55	Tension at 1st bar-tacking section This item sets needle thread tension at 1st bar-tacking section. 	0 to 200	1	-
S56	Tension at 2nd bar-tacking section This item sets needle thread tension at 2nd bar-tacking section. 	0 to 200	1	*2
S57	Setting of needle thread tension at the start of sewing This item sets needle thread tension of tie stitching at the start of sewing. 	0 to 200	1	-
S58	Setting of needle thread tension of basting This item sets needle thread tension of basting. 	0 to 200	1	*3

5. OPERATION OF THE SEWING MACHINE

NO.	Item	Setting range	Edit unit	Remarks
S59	ACT timing adjustment at the start of 1st bar-tacking This item adjusts needle thread tension output start timing at 1st bar-tacking section. 	-5 to 5	1 stitch	*2
S60	ACT timing adjustment at the start of right overedging This item adjusts needle thread tension output start timing at right overedging section. 	-5 to 5	1 stitch	*2
S61	ACT timing adjustment at the start of 2nd bar-tacking This item adjusts needle thread tension output start timing at 2nd bar-tacking section. 	-5 to 5	1 stitch	*2
S62	Number of stitches of tie stitching at the start of sewing This item sets number of stitches of tie stitching at the start of sewing. 	0 to 8	1 stitch	-
S63	Sewing pitch of tie stitching at the start of sewing This item sets sewing pitch of tie stitching at the start of sewing. 	0.00 to 0.70	0.05mm	*2
S64	Tie stitching width at the start of sewing This item sets tie stitching width at the start of sewing. 	0.0 to 3.0	0.1mm	-
S65	Lengthwise compensation of tie stitching at the start of sewing This item sets start position of tie stitching in lengthwise direction at the start of sewing. 	0.0 to 5.0	0.1mm	*2
S66	Crosswise compensation of tie stitching at the start of sewing This item sets start position of tie stitching in crosswise direction at the start of sewing. 	0.0 to 2.0	0.1mm	*2
S67	Tie stitching width at the end of sewing This item sets tie stitching width at the end of sewing. 	0.1 to 1.5	0.1mm	-
S68	Number of stitches of tie stitching at the end of sewing This item sets number of stitches of tie stitching at the end of sewing. 	0 to 8	1 stitch	-
S69	Lengthwise compensation of tie stitching at the end of sewing This item sets start position of tie stitching in lengthwise direction at the end of sewing. 	0.0 to 5.0	0.1mm	*2
S70	Crosswise compensation of tie stitching at the end of sewing This item sets start position of tie stitching in crosswise direction at the end of sewing. 	0.0 to 2.0	0.1mm	*2

NO.	Item	Setting range	Edit unit	Remarks
S81	Knife motion This item sets "With/without motion" of normal cloth cutting knife.  : Normal knife motion OFF  : Normal knife motion ON	—	—	—
S83	Knife motion at 1st cycle of double stitching This item sets "With/without motion" of cloth cutting knife at 1st cycle when double stitching is performed.  : Normal knife motion OFF  : Normal knife motion ON	—	—	*2, *3
S84	Maximum speed limitation This item sets max. speed limitation of the sewing machine. The maximum value of data edit is equal to the number of revolutions of K07 Maximum speed limitation of the memory switch data. → Refer to 21. Memory switch list 	400 to 4200	100rpm	—
S86	Pitch of going This item sets sewing pitch of going side of bar-tacking shape (Shape Nos. 27, 28, 29 and 30 of S01). 	0.200 to 2.500	0.025mm	—
S87	Width of going This item sets width of going side of bar-tacking shape (Shape Nos. 27, 28, 29 and 30 of S01). 	0.1 to 3.0	0.05mm	—
S88	Pitch of coming This item sets sewing pitch of coming side of bar-tacking shape (Shape Nos. 27, 28, 29 and 30 of S01). 	0.200 to 2.500	0.025mm	—
S89	Width of coming This item sets width of coming side of bar-tacking shape (Shape Nos. 27, 28, 29 and 30 of S01). 	0.1 to 3.0	0.05mm	—

5-14. Copying sewing pattern

Data of pattern No., which has been already registered can be copied to pattern No., which has not been used. Overwriting copy of the pattern is prohibited. When you desire to overwrite, perform it after erasing the pattern once.

1) Set the mode to input mode.

When the back-light of LCD display ❶ shows the input mode in blue color, it is possible to copy. When the back-light shows the sewing mode in green color, press **READY** key ❷  to change over to the input mode.

2) Select pattern No. of copy source.

Select pattern No. of copy source from the pattern selection screen.

→ Refer to 5. **Performing pattern selection**

When creating pattern data quite newly, it is convenient to copy the initial value pattern.

→ Refer to 10. **Using initial value pattern**

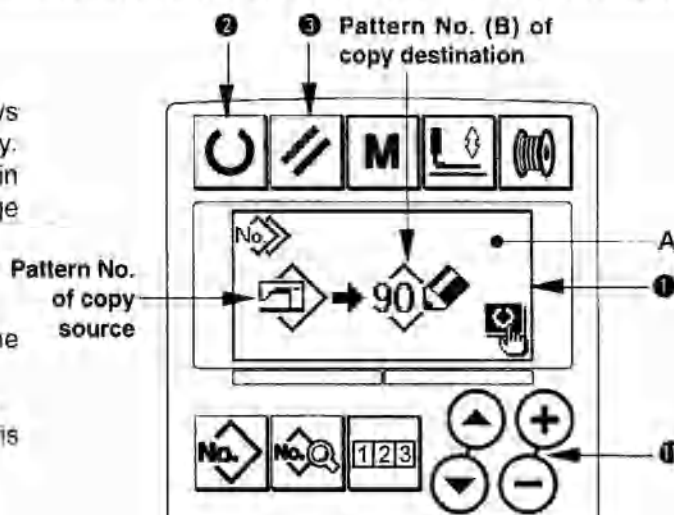



5. OPERATION OF THE SEWING MACHINE

3) Call copy screen.

Press COPY key , and copy screen A is displayed.

4) Select pattern No. of copy destination.

Pattern No. B which is not used flashes on and off in the display. Press DATA CHANGE key  , and select the No. you desire to copy. When you desire to erase the pattern, select the garbage can .

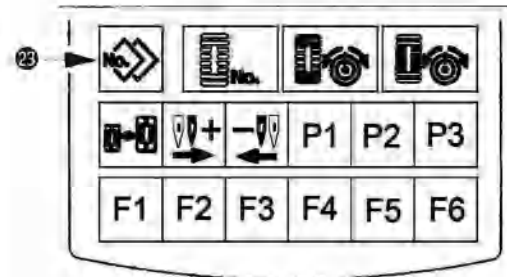

5) Start copying.

Press READY key  to start copying. After two seconds, the pattern No. which is created by copying returns to the input screen in the state of being selected.

Press RESET key , and the screen returns to the former one without copying.

* In addition, cycle data and continuous stitching data can be copied by the same method.

5-15. Using pattern register key

Register pattern Nos. which are frequently used with the pattern register key and use them.

Patterns which have been registered can be selected by pressing only the pattern register key under the input mode.



(1) Method of register

1) Set the mode to the input mode.



When the back-light of LCD display  shows the input mode in blue color, it is possible to register patterns.

When the back-light shows the sewing mode in green color, press READY key  to change over to the input mode.

2) Call pattern register screen.

Press key (P1 to P3)  to  which you desire to register pattern No. for as long as 3 seconds, and pattern register screen A is displayed.

3) Select pattern No.

Pattern No. B which can be used at present flashes on and off in the display. Press ITEM SELECTION key  , and select the pattern No. you desire to register.

When trash can  is selected, register can be released.

4) Start register.

Press READY key  to start register and the screen returns to the input screen after two seconds.

Press RESET key , and the screen returns to the former one without registering.

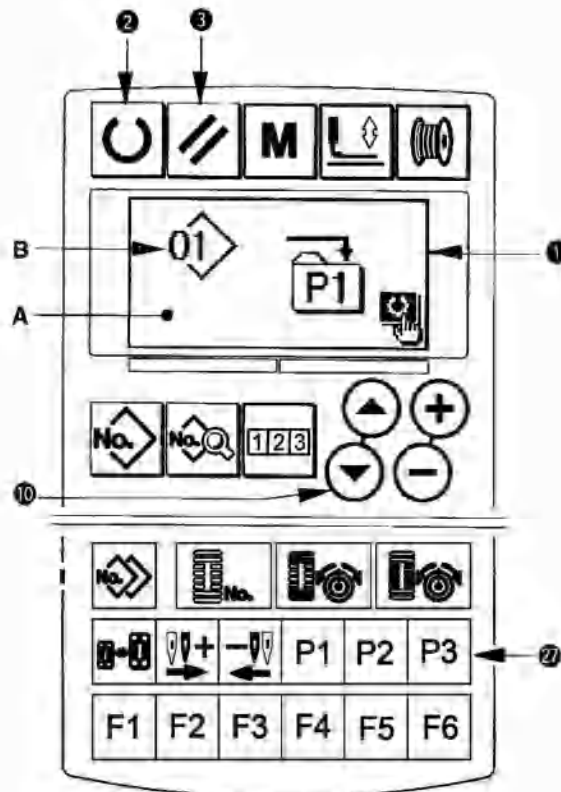

(2) Register status at the time of your purchase

Register key	Registered pattern No.
P1	Pattern No. 1
P2	Pattern No. 2
P3	Pattern No. 3

5-16. Using parameter register key

Register parameters which are frequently used with parameter register key and use them.



Parameters which have been registered can be selected by pressing only the parameter register key under the input mode. In addition, this key can use the same method as that of 15. **Using pattern register key** since this key can register not only the parameters but also pattern Nos.

(1) Method of register



1) Set the mode to the input mode.

When the back-light of LCD display ① shows the input mode in blue color, it is possible to register parameters. When the back-light shows the sewing mode in green color, press READY key ②  to change over to the input mode.



2) Call parameter register screen.

Press key (F1 to F6) ③  to  which you desire to register the parameter for as long as 3 seconds, and parameter register screen A is displayed.

3) Select parameter.





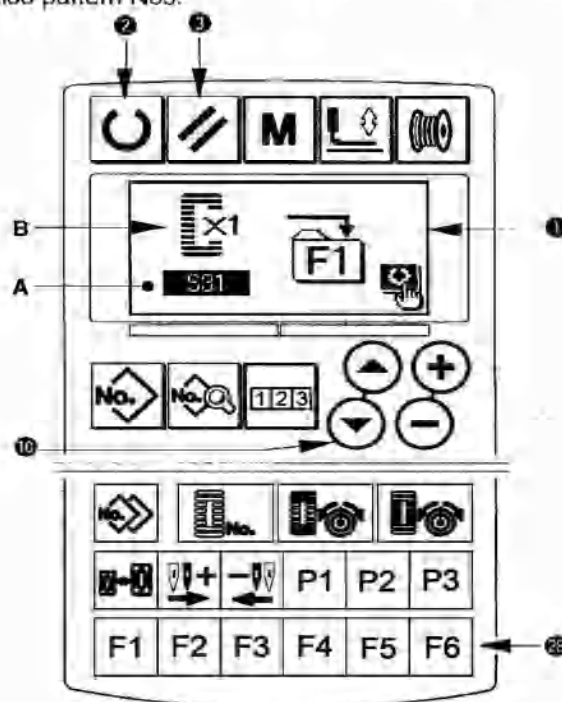

Item B which can be registered with the key flashes on and off. Press ITEM SELECTION key ⑩  to select the item you desire to register. Items which can be registered are sewing data, parameters of memory switches (level 1) and pattern Nos. In addition, when trash can  is selected, register can be released.

4) Start register.

Press READY key ②  to start register and the screen returns to the input screen after two seconds. Press RESET key ③ , and the screen returns to the former one without registering.



(2) Register status at the time of your purchase

Register key	Registered parameter
F1	Changeover of single/double stitching 
F2	Basting (off/number of times) 
F3	Basting needle thread tension setting 
F4	Plural motions of cloth cutting knife Ineffective/effective 
F5	Cloth cutting knife size 
F6	Setting of needle thread tension at the start of sewing 

5-17. Performing continuous stitching

This sewing machine can perform continuous stitching which is capable of continuously sewing plural sewing pattern data without lifting the presser foot. It is possible to automatically sew up to maximum 6 shapes in one cycle.

In addition, registration of as many as 20 data can be performed. Copy and use the data to fill the needs.

→ Refer to 14. **Copying sewing pattern**

* **It is necessary to change the parts from the state at the time of your purchase according to the setting conditions.**

(1) Selection of continuous stitching data

1) Set the mode to the input mode.



When the back-light of LCD display ① shows the input mode in blue color, it is possible to select continuous stitching data. When the back-light shows the sewing mode in green color, press READY key ②  to change over to the input mode.

2) Call pattern selection screen.

Press PATTERN NO. key ⑦ , and pattern selection screen A is displayed.

Pattern No. B which is selected at present flashes on and off.

3) Select continuous stitching.

Press ITEM SELECTION key ⑩  , and patterns which have been registered are changed over and displayed in order. Cycle data No. and continuous stitching data No. which have been registered after the last registered pattern No. are displayed. Here, select the continuous stitching data No. which you desire to sew.

4) Perform sewing.

Press READY key ②  in the state that continuous stitching data is selected, and the back-light of LCD display ① shows green and it is possible to sew. Continuous stitching data No. 1 only has been registered at the time of your purchase. However, sewing status cannot be obtained since the sewing pattern has not been inputted. Perform inputting of sewing pattern referring to 2) **Method of editing continuous stitching data** on the next page.

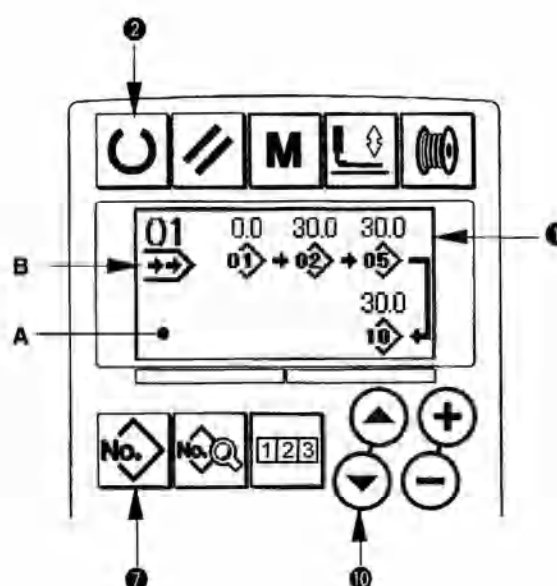



(2) Method of editing continuous stitching data

1) Set the mode to the input mode.

When the back-light of LCD display ① shows the input mode in blue color, it is possible to select continuous stitching data. When the back-light shows the sewing mode in green color, press READY key ②  to change over to the input mode.

2) Call continuous stitching data No. to edit.

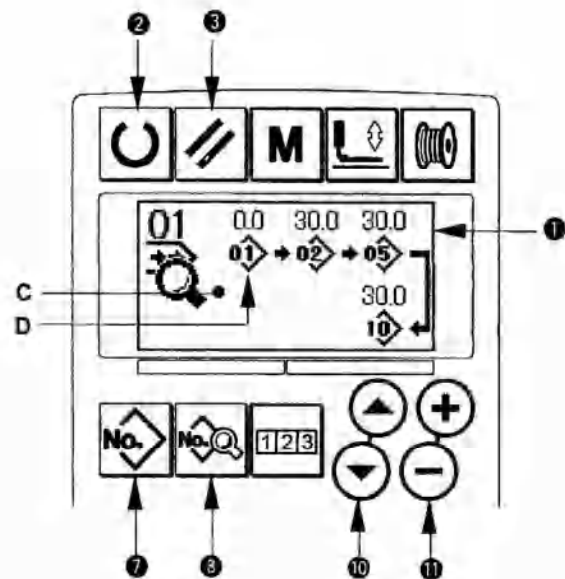

Press PATTERN No. key ⑦  to call pattern selection screen, and pattern No. B which is selected at present flashes on and off. Press ITEM SELECTION key ⑩ , and patterns which have been registered are changed over and displayed in order. Cycle data No. and continuous stitching data No. which have been registered after the last pattern No. are displayed. Here, select the continuous stitching No. which you desire to sew.



3) Set continuous stitching data to editing status.

Press DATA key ③ , and continuous stitching data editing display C appears. Pattern No. D which is sewn first flashes on and off. In this state, it is possible to edit the data.

4) Select editing point.

Press ITEM SELECTION key ⑩ , and editing point moves in order of "pattern No. → jump feed mount → pattern No. → jump feed amount" and flashes on and off. When moving the editing point up to the last data, additional indication pictograph  is displayed.

5) Change data of selected editing point.

Press DATA CHANGE key ⑪ , and data of editing point can be changed.

When the editing point is at the pattern No. :

Pattern No. which has been registered is displayed and it is possible to select.

When the editing point is at the jump feed :

It is possible to edit numerical value within the range of ± 120 mm. In addition, press RESET key ③  and the pattern data of editing point can be deleted.

Repeat steps 4) and 5) to perform editing data.

* Input is completed by the steps above. For the continuous stitching, however, input all data within the range of the presser size. Error message will be shown when the data exceeds the range. Be sure to precisely input the presser size.

→ Refer to 4. Inputting presser type

5-18. Performing cycle stitching

This sewing machine can perform sewing of plural sewing pattern data in one cycle in the order of the data. Use this stitching when sewing plural different button holes on the sewing product since as many as 15 different kinds of patterns can be inputted.

In addition, registration of as many as 20 cycles can be performed. Copy and use the data to fill the needs.

→ Refer to **5-14. Copying sewing pattern**

(1) Selection of cycle data

1) Set the mode to the input mode.

When the back-light of LCD display ❶ shows the input mode in blue color, it is possible to select cycle data. When the back-light shows the sewing mode in green color, press READY key ❷  to change over to the input mode.

2) Call pattern selection screen.

Press PATTERN No. key ❸ , and pattern selection screen A is displayed.

Pattern No. B which is selected at present flashes on and off.

3) Select cycle stitching data.

Press ITEM SELECTION key ❹ , and patterns which have been registered are changed over and displayed in order. Cycle data No. and continuous stitching data No. which have been registered after the last registered pattern No. are displayed. Here, select the cycle data No. which you desire to sew.

4) Perform sewing.

Press READY key ❷  in the state that the cycle data is selected, and the back-light of LCD display ❶ shows green and it is possible to sew.

Cycle data No. 1 only has been registered at the time of your purchase. However, sewing status cannot be obtained since the sewing pattern has not been inputted. Perform inputting of sewing pattern referring to **2) Method of editing cycle data** on the next page.

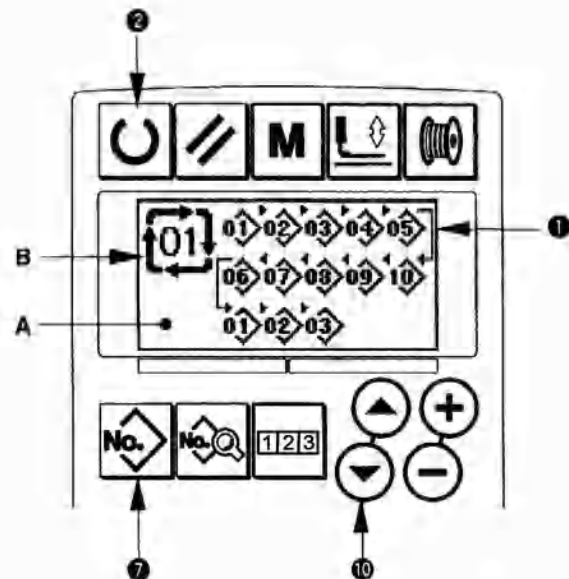



(2) Method of editing cycle data

1) Set the mode to input mode.

When the back-light of LCD display ❶ shows the input mode in blue color, it is possible to input the cycle data. When the back-light is the sewing mode in green color, press READY key ❷  to change over to the input mode.

2) Call cycle data No. to edit.

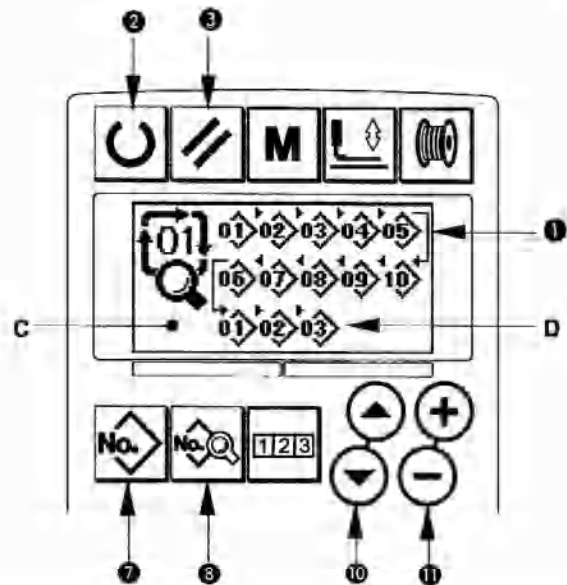

Press PATTERN No. key ❸  to call pattern selection screen, and pattern No. B which is selected at present flashes on and off. Press ITEM SELECTION key ❹ , and patterns which have been registered are changed over and displayed in order. Cycle data No. and continuous stitching data No. which have been registered after the last registered pattern No. are displayed. Here, select the cycle data No. which you desire to sew.



3) Set cycle data to editing status.

Press DATA key ❸ , and cycle data editing display C appears. Pattern No. D which is sewn first flashes on and off. In this state, it is possible to edit the data.

4) Select editing point.

Press ITEM SELECTION key ❹ , and editing point moves in order and flashes on and off. When moving the editing point up to the last data, additional indication pictograph  is displayed.

5) Change data of selected editing point.

Press DATA CHANGE key ❺  and data of editing point can be changed.

Pattern No. which has been registered is displayed and it is possible to select.

In addition, press RESET key ❻ , and the pattern data of editing point can be deleted.

Repeat steps 4) and 5) to perform editing data.

5-19. Explanation of plural motions of knife

This sewing machine can automatically actuate the knife plural times and sew a buttonhole larger than the size of knife by setting the size of knife attached from the operation panel. Set and use this function when sewing various sewing shapes without replacing the knife.





5. OPERATION OF THE SEWING MACHINE

(1) Setting of plural motions of knife



1) Set the mode to the input mode.

When the back-light of LCD display ① shows the input mode in blue color, it is possible to edit the memory switch data. When the back-light shows the sewing mode in green color, press READY key ②  to change over to the input mode.

2) Input the size of cloth cutting knife

Press MODE key ④  to display memory switch data (level 1) edit screen A. Press ITEM SELECTION key ⑩  to call  Cloth cutting knife size B. Then set size C of knife attached with DATA CHANGE key ⑪  => For the details, refer to 21. **Memory switch data list.**

3) Set the function of the plural motions of cloth cutting knife to effective.

Next, press again ITEM SELECTION key ⑩  to call  Function of the plural motions of cloth cutting knife D. Then set the plural motions of cloth cutting knife to the effective status with DATA CHANGE key ⑪ . For the details, refer to 21. **Memory switch data list.**

4) Perform sewing.

Press READY key ② , and the back-light of LCD display ① becomes green. Then it is possible to sew. At this time, when S02 Cloth cutting length is set to a size larger than U18 Cloth cutting knife size which has been set above, the plural motions of knife is automatically performed for sewing.

* If a buttonhole smaller than the size of knife attached is desired to be sewn, error 489 will be displayed.

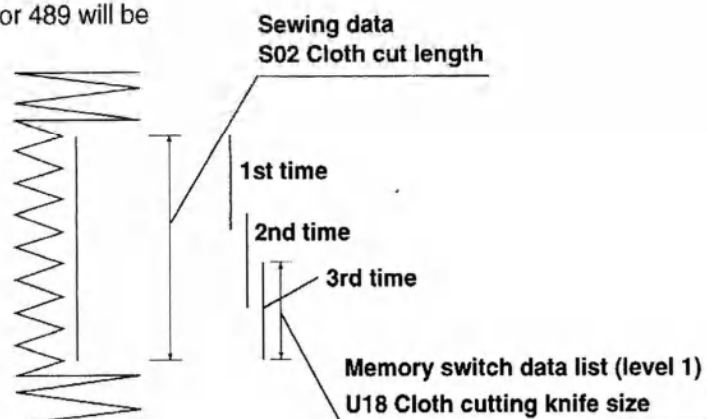
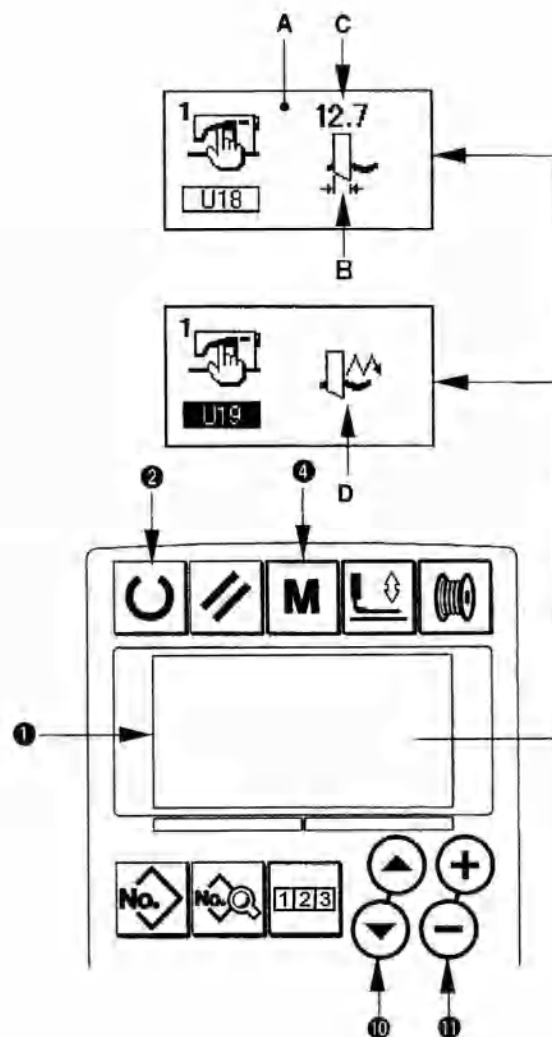

5-20. Method of changing memory switch data

1) Set the mode to input mode.

When the back-light of LCD display ❶ shows the input mode in blue color, it is possible to change the memory switch data. When the back-light shows the sewing mode in green color, press READY key ❷  to change over to the input mode.

2) Call memory switch data edit screen.



Press MODE key ❸ , and memory switch data (level 1) edit screen A is displayed. Further hold pressing the key for 3 seconds, and memory switch data (level 2) edit screen B is displayed.



3) Select memory switch data to change.

Press ITEM SELECTION key ❹  and select the data item which you desire to change.

4) Change data.

There are one data item to change the numerical value and the other data item to select the pictograph in the memory switch data.

No. such as  is attached to the data item to change the numerical value. Set value can be changed by increasing/decreasing the value with DATA CHANGE key ❺ .

No. such as  is attached to the data item to select the pictograph. Pictograph can be selected with DATA CHANGE key ❺ .

→ For the details of memory switch data, refer to

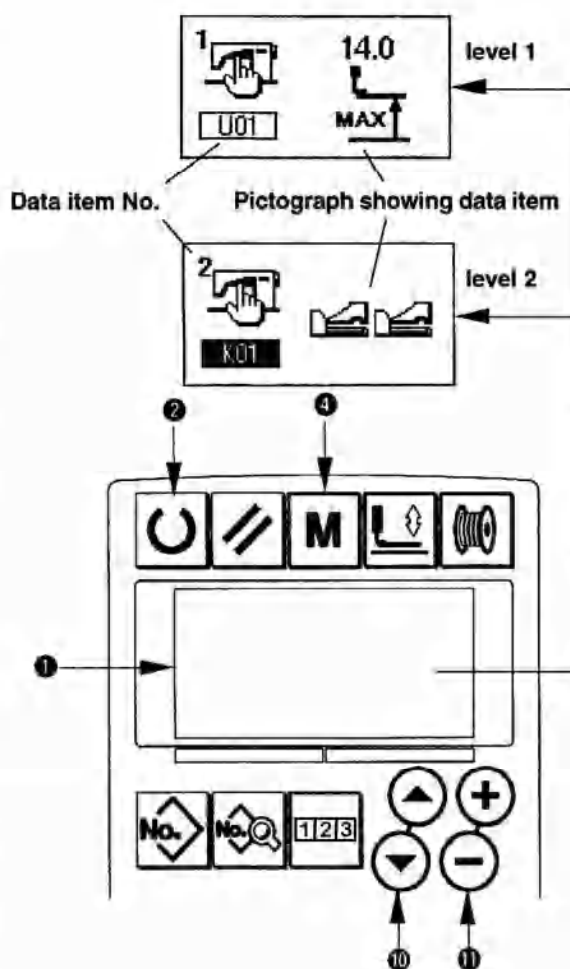













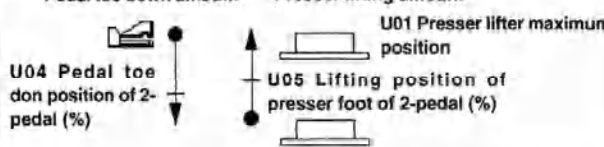



5-21. Memory switch data list



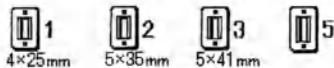











(1) Level 1

- ☆ Memory switch data (level 1) are the motion data that the sewing machine has in common and the data that operate on all sewing patterns in common.

5. OPERATION OF THE SEWING MACHINE

No.	Item	Setting range	Edit unit	Initial value
U01	Presser lifter maximum position Height of maximum position of pedal operation is set. 	0 to 17.0	0.1mm	14.0mm
U02	Presser lifter intermediate position Height of intermediate position of pedal operation is set. 	0 to 14.0	0.1mm	6.0mm
U03	Presser lifter cloth setting position Height of cloth setting position of pedal operation is set. 	0 to 14.0	0.1mm	0.0mm
U04	Pedal toe down position of 2-pedal (%) Operation feeling at the time of 2-pedal is set. Refer to the item below. 	5 to 95	1%	80%
U05	Lifting position of presser foot of 2-pedal (%) Operation feeling at the time of 2-pedal is set.  Pedal toe down amount Presser lifting amount  U04 Pedal toe down position of 2-pedal (%) U05 Lifting position of presser foot of 2-pedal (%) U01 Presser lifter maximum position	5 to 95	1%	50%
U06	Needle thread tension at sewing end setting 	0 to 200	1	35
U07	Needle thread tension at thread trimming setting 	0 to 200	1	35
U08	Needle thread tension of basting for sewing together setting 	0 to 200	1	60
U09	Soft-start speed setting 1st stitch 	400 to 4200	100rpm	800rpm
U10	Soft-start speed setting 2nd stitch 	400 to 4200	100rpm	800rpm
U11	Soft-start speed setting 3rd stitch 	400 to 4200	100rpm	2000rpm
U12	Soft-start speed setting 4th stitch 	400 to 4200	100rpm	3000rpm
U13	Soft-start speed setting 5th stitch 	400 to 4200	100rpm	4000rpm
U14	Kind of presser Set the kind of the presser. → 4. Inputting presser type  1 4×25mm 2 5×35mm 3 5×41mm 5	-	-	Type 1
U15	Presser size width When type 5 of U14 Kind of presser is set, input the width of the presser. 	3.0 to 10.0	0.1mm	3.0mm
U16	Presser size length When type 5 of U14 Kind of presser is set, input the length of the presser. 	10.0 to 120.0	0.5mm	10.0mm
U17	Sewing start position (Feed direction) Sewing start position in terms of presser is set. Set this item when starting position is desired to be shifted due to overlapped section or the like. 	2.5 to 110.0	0.1mm	2.5mm









5. OPERATION OF THE SEWING MACHINE

No.	Item	Setting range	Edit unit	Initial value
U18	Cloth cutting knife size Input knife size used. 	3.0 to 32.0	0.1mm	32.0mm
U19	Function of plural motions of cloth cutting knife Ineffective/effective  Ineffective  Effective	—	—	Ineffective
U20	Function of thread breakage detection Ineffective/effective  Ineffective  Effective	—	—	Effective
U21	Selection of presser position at the time of ON of READY key (Up/Down) Presser foot position when READY key is pressed is set.  Presser up  Presser down	—	—	Presser Up
U22	Selection of the position of presser foot at the time of the end of sewing (Up/Down) This item sets the position of presser foot at the time of the end of sewing. (Effective only at the time of 1-pedal setting)  Presser up  Presser down	—	—	Presser Up
U23	Needle thread trimming motion start distance Distance from the start of sewing to the start of needle thread trimmer release motion is inputted. 	0 to 15.0	0.1mm	1.0mm
U24	Bobbin thread trimming motion start distance Distance from the start of sewing to the start of bobbin thread trimmer release motion is inputted. 	0 to 15.0	0.1mm	1.5mm
U25	Counter updating unit Unit to update sewing counter is set. 	1 to 30	1	1
U26	Total number of stitches Non-display/Display  Non-display  Display	—	—	Non-display

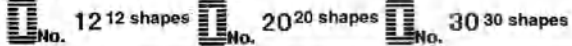
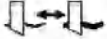



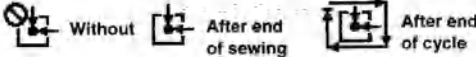
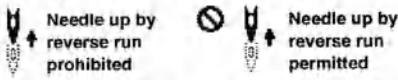



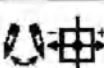
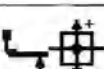
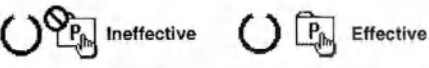

5. OPERATION OF THE SEWING MACHINE

(2) Level 2

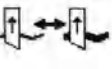
☆ Press MODE switch for as long as three seconds and it is possible to edit.

NO.	Item	Setting range	Edit unit	Initial value
K01	Pedal selection Pedal type is set. → 3. How to use the pedal  2-pedal 1-pedal 1-pedal (Without intermediate position) (With intermediate position)	—	—	2-pedal
K02	Parameter setting change Permitted/Prohibited Prohibition of change of sewing data and memory switch data is set.  Change permitted Change prohibited	—	—	Change permitted
K03	Function of prohibition of selection of kind of presser Permitted/Prohibited Prohibition of change of U14 Kind of presser is set.  Change permitted Change prohibited	—	—	Change permitted
K04	Sewing shape selection level Number of sewing shapes which can be sewn can be increased. (Max. 30 shapes)  No. 12 12 shapes No. 20 20 shapes No. 30 30 shapes	—	—	12 shapes
K05	Cloth cutting knife power Output power of cloth cutting knife is set. 0 : Min. power → 3 : Max. power 	0 to 3	1	1
K06	Selection of machine type Type of sewing machine head is set. 0 : Standard type 1 : Dry head type  TYPE	0 to 1	1	0 (Standard type)
K07	Max. speed limitation speed setting Max. speed of sewing machine can be limited. When K06 Selection of machine type is set to dry head type, max. speed is automatically limited to 3,300 rpm.  max	400 to 4200	100rpm	3600 rpm
K08	Compensation of unsteady needle thread tension Output value of needle thread tension is wholly offset and compensated. 	-30 to 30	1	0
K09	Output time of needle thread tension changed value When data related to needle thread tension is changed, the changed value is output as long as the set-up time.  Without output Output of set-up time	0 to 20	1s	0s
K10	Function of origin retrieval each time Origin retrieval is performed after completion of sewing or completion of cycle.  Without After end of sewing After end of cycle	—	—	Without
K11	Needle up by reverse run Permitted/Prohibited When U01 Presser lifter maximum position is set to 14.0 mm or more, motion of needle up by reverse run is automatically performed and the machine stops. Prohibition of the motion can be set.  Needle up by reverse run prohibited Needle up by reverse run permitted	—	—	Permitted
K12	Knife solenoid lowering time setting 	25 to 100	5ms	35

5. OPERATION OF THE SEWING MACHINE

No.	Item	Setting range	Edit unit	Initial value
K13	Knife solenoid lifting time setting 	5 to 100	5ms	15
K14	Knife cylinder lowering time (Optional) 	5 to 300	5ms	50
K15	Y-feed motor origin compensation 	-120 to 400	1 pulse (0.025mm)	0
K16	Needle-rocking motor origin compensation 	-10 to 10	1 pulse (0.05mm)	0
K17	Presser lifter motor origin compensation 	-100 to 10	1 pulse (0.05mm)	0
K18	Pattern selection function under sewing mode Ineffective/effective 	-	-	Ineffective
K19	Thread trimming on the way in continuous stitching Permitted/Prohibited 	-	-	Permitted
K20	Cloth cutting knife return power This item sets output power at the time of returning the cloth cutting knife. 	0 to 3	1	0
K21	Release amount of bobbin thread trimmer at the start of sewing This item sets the amount of releasing the bobbin thread trimmer at the start of sewing. 	0 to 15	1 pulse	8
K22	Presser lifter speed This item sets presser lifter speed. 	1 to 3	-	2
K51	Needle thread trimming adjustment mode start Needle thread trimming adjustment motion starts with READY key ON. 	-	-	-
K52	Bobbin thread trimming adjustment mode start Bobbin thread trimming adjustment motion starts with READY key ON. 	-	-	-
K53	Sensor check mode start Sensor check starts with READY key ON. 	-	-	-

6. MAINTENANCE

6-1. Adjusting the needle-to-hook relation

WARNING :

To protect against possible personal injury due to abrupt start of the machine, be sure to start the following work after turning the power off and ascertaining that the motor is at rest.

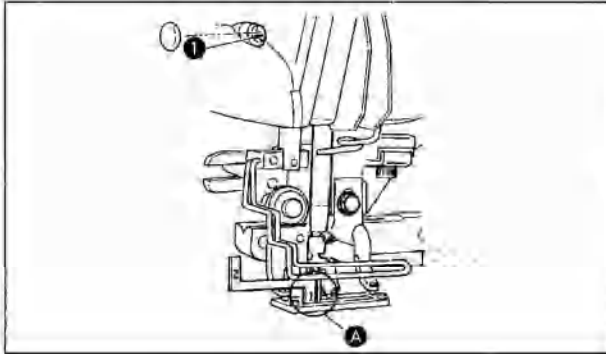

Adjust the needle-to-hook relation when the needle enters the center of the needle hole in the throat plate.

(1) Needle bar height

- 1) Bring down the needle bar to the lowest point.
- 2) Insert the part [1] **A** of timing gauge into the gap between the bottom end of needle bar and throat plate, where the bottom end of the needle bar touches the top of the part [1] **A** of the timing gauge.
- 3) Loosen needle bar connection screw **1**, and adjust the height of the needle bar.

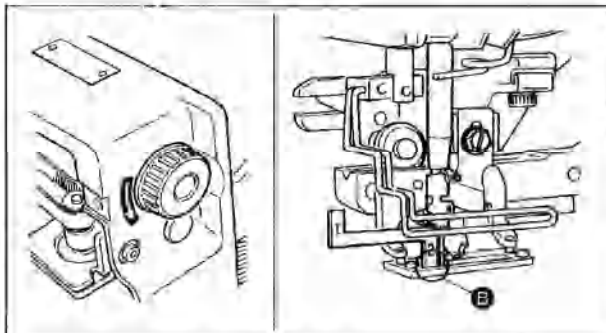
(2) Set the needle to hook relation in the following way :

- 1) Rotate the hand pulley in the correct direction until the needle starts to go up from its lowest point.
- 2) Insert the part [2] **B** of the timing gauge into the gap between the bottom end of the needle bar and the throat plate, where the bottom end of the needle bar touches the top of the part [2] **B** of the timing gauge.
- 3) Loosen setscrew **C** of the hook sleeve, and align blade point of the sewing hook with the center of needle hole. Make adjustment so that a clearance of approx. 0.05 mm is provided between the needle and the blade point of the hook.

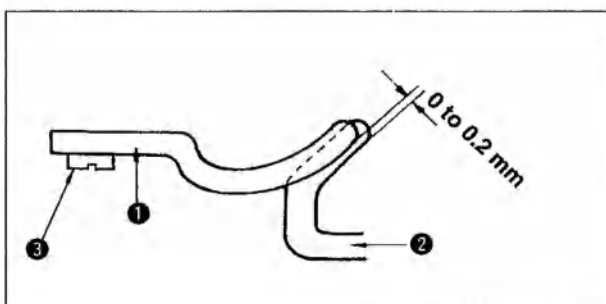
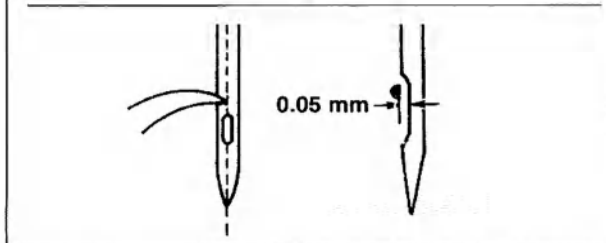
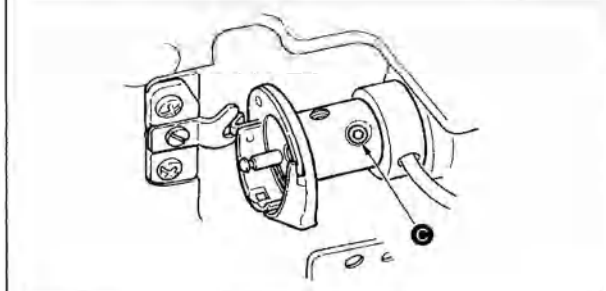
(3) Adjusting the bobbin case positioning stopper

Adjust with setscrew **3** so that the contact of the top end of bobbin case positioning stopper **1** and the end of inner hook **2** is 0 to 0.2 mm.

6-2. Adjusting the needle thread trimmer



WARNING :

To protect against possible personal injury due to abrupt start of the machine, be sure to start the following work after turning the power off and ascertaining that the motor is at rest.

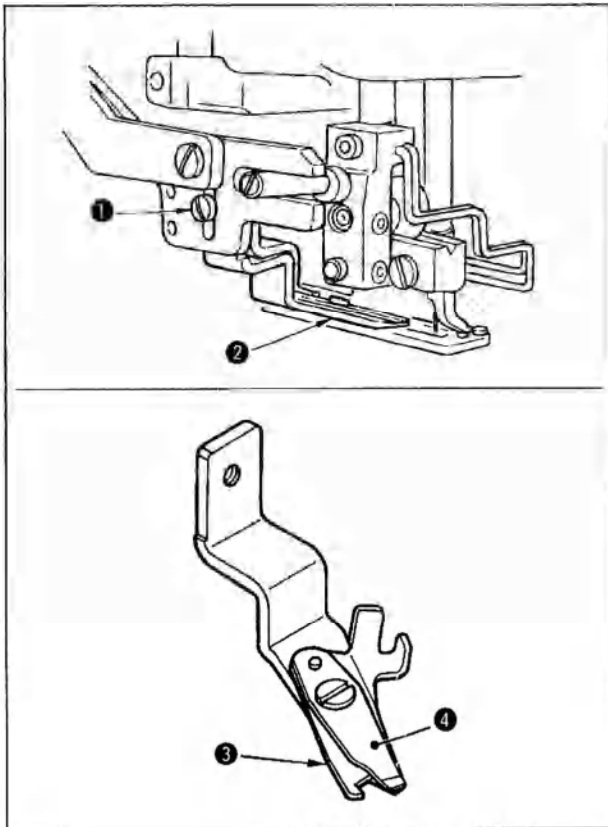

(1) Adjusting the thread grasping force of the needle thread trimmer

If the needle thread trimmer fails to provide consistent thread grasping force, the needle thread can slip off at the beginning of sewing.

- 1) If the thread grasping force of the needle thread trimmer has reduced, loosen setscrews ❶ and detach needle thread trimmer ❷.
- 2) Slightly bend the top end of thread presser spring ❸ so that it comes in contact with thread trimming blade of upper knife ❹ over the length with no clearance and so that the needle thread trimmer securely holds the thread regardless of the position of the thread trimming blade at which the thread is trimmed.

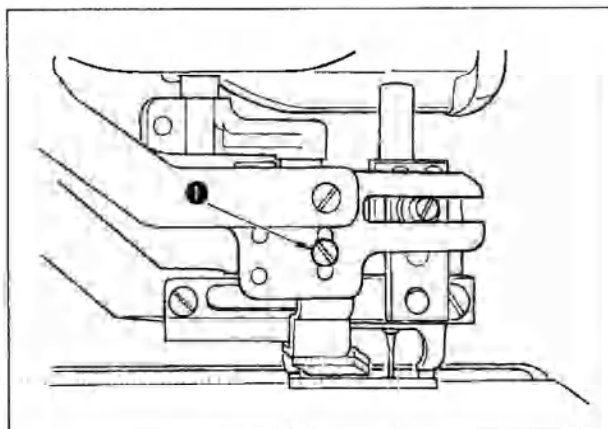

(2) Adjusting the height of the needle thread trimmer

To adjust the height of the needle thread trimmer, loosen setscrew ❶. Set the height of trimmer as low as possible, provided that it does not touch work clamp check, in order to minimize the length of remaining thread on the needle after trimming.

Note that the work clamp check tilts when sewing a multi-layered portion of the material, attach the needle thread trimmer to slightly raise the installing position of the trimmer.

When replacing the needle thread trimmer, make sure that the trimmer normally works under the needle thread trimmer adjusting mode (memory switch level 2 : K51).



6-3. Adjusting the presser bar pressure



WARNING :

To protect against possible personal injury due to abrupt start of the machine, be sure to start the following work after turning the power off and ascertaining that the motor is at rest.

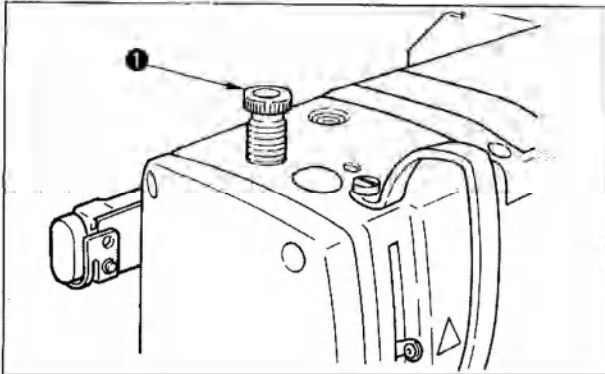

To adjust the pressure applied by the presser bar to fabric, turn presser spring regulator ①. When the pressure is not enough to prevent fabric from puckering, turn regulator ① clockwise.

6-4. Adjusting of the bobbin presser unit



WARNING :

To protect against possible personal injury due to abrupt start of the machine, be sure to start the following work after turning the power off and ascertaining that the motor is at rest.

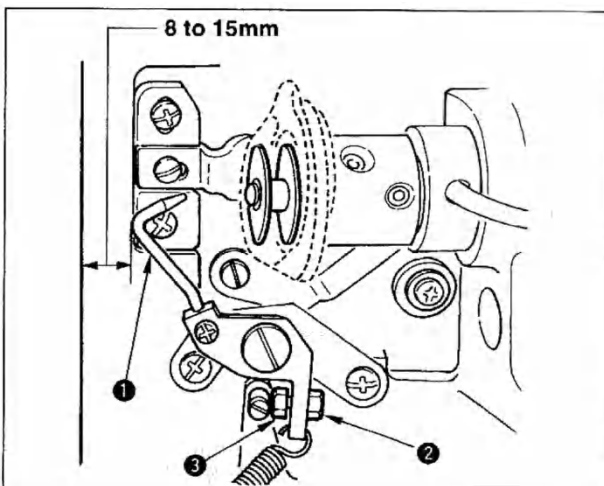

Loosen nut ② and adjust the position with stopper spring ③ so that the distance from the front end of machine bed to bobbin presser ① is 8 to 15 mm when the sewing machine stops. Then tighten nut ②.

6-5. Thread tension

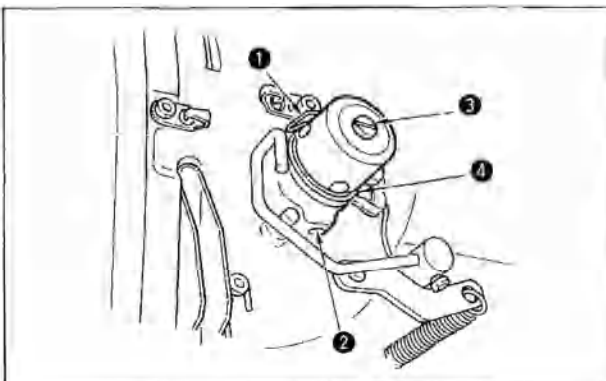

(1) Thread take-up spring (purl stitch)

- 1) The thread take-up amount of thread take-up spring ① is 8 to 10 mm, and the appropriate pressure at the start is approximately 0.06 to 0.1N.
- 2) To change the stroke of the thread take-up spring, loosen screw ②, insert a thin screwdriver into the slot of thread tension post ③, and turn it.
- 3) To change the pressure of the thread take-up spring, insert a thin screwdriver into the slot of thread tension post ③ while screw ② is tightened, and turn it. Turning it clockwise will increase the pressure of the thread take-up spring. Turning it counterclockwise will decrease the pressure.

6. MAINTENANCE

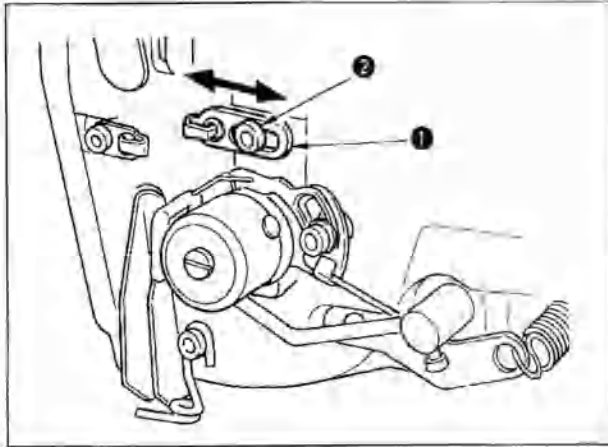

(2) Adjusting the thread take-up amount of the thread take-up lever

The thread take-up amount of the thread take-up lever should be adjusted in accordance with the thickness of the sewing products so as to obtain well-tightened stitches.

- a. For heavy-weight materials, loosen setscrew **2** in thread guide **1**, and move the thread guide to the left. The thread take-up amount of the thread take-up lever will be increased.
- b. For light-weight materials, move thread guide **1** to the right. The thread take-up amount of the thread take-up lever will be reduced.

6-6. Cleaning the filter



WARNING :

To protect against possible personal injury due to abrupt start of the machine, be sure to start the following work after turning the power off and ascertaining that the motor is at rest.

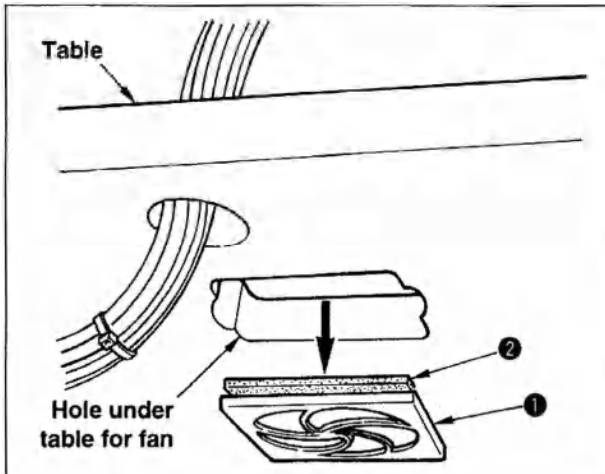

Clean filter **2** of the fan located on the bottom surface of the machine table (bed base) once every week.

- 1) Pull the screen kit **1** in the direction of the arrow to remove it.
- 2) Wash the filter **2** under running water.
- 3) Reinstall the filter **2** and the screen kit **1**.

6-7. Replacing the fuse



WARNING :

1. To avoid electrical shock hazards, turn OFF the power and open the control box cover after about five minutes have passed.
2. Open the control box cover after turning OFF the power without fail. Then, replace with a new fuse with the specified capacity.

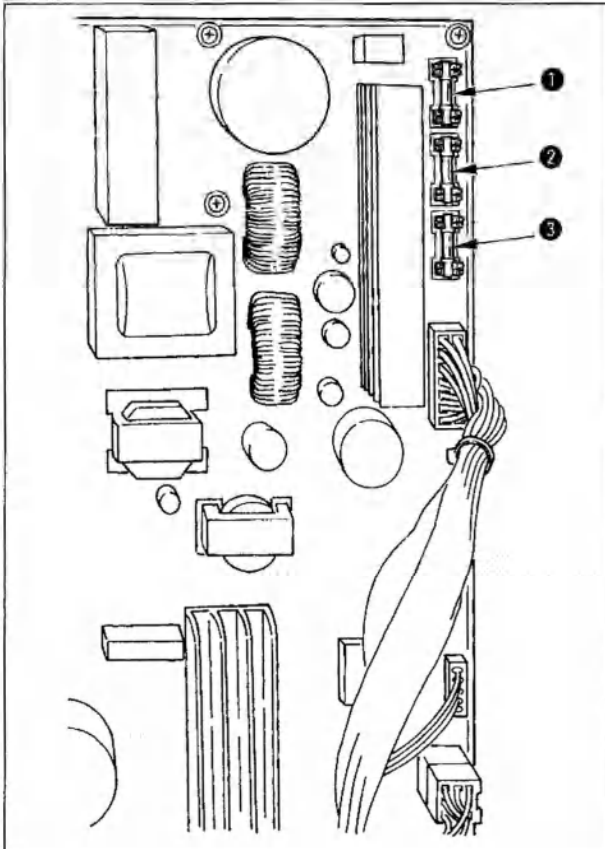

The machine uses the following three fuses :

- ❶ For pulse motor power supply protection
5A (time-lag fuse)
- ❷ For solenoid and pulse motor power supply protection
3.15A (time-lag fuse)
- ❸ For control power supply protection
2A (fast-blow type fuse)

7、GWUGE COMPONENTS

7-1.Cloth cutting knife

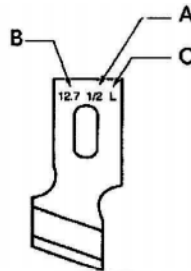

A Knife size (inch)	B Knife size (inch)	C Mark	D Part NO.
1/4	6.4	F	CS2702047F
3/8	9.5	K	CS2702047K
7/16	11.1	I	CS2702047I
1/2	12.7	L	CS2702047L
9/16	14.3	V	CS2702047V
5/8	15.9	M	CS2702047M
11/16	17.5	A	CS2702047A
3/4	19.1	N	CS2702047N
7/8	22.2	P	CS2702047P
1	25.4	Q	CS2702047Q
1-1/4	31.8	S	CS2702047S

7-2.Throat plate

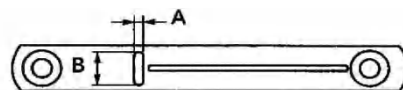

Type	Stitch width	
	5mm (Marking • AxB)	6mm (Marking • AxB)
Standard (S)	CS79004350 (S5 • 1.4x6.2)	CS79004351 (S6 • 1.4x7.4)
For knits (K)	CS79004352 (K5 • 1.2x6.2)	CS79004353 (K6 • 1.2x7.4)

7-3.Presser

Stitch widty 5mm







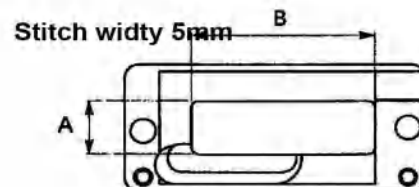











Type	Size (AxB)		
	1 (4x25)	2 (5x35)	3(5x41)
Standard (S)	CS01552781	CS01552782	CS01552783
Fof knits (K)	CS01508771	CS01508772	CS01508773

Stitch widty 6mm





















Type	Size (AxB)
Standard (S)	3 (6x41)
	CS014524409

















8、 ERROR CODE LIST

Error code		Description	How to recover	Place of recovery
E001		Contact of initialization of EEPROM of MAIN CONTROL p.c.b. When data is not written in EEPROM or data is broken, initialization of the data is automatically informed.	Turn OFF the power.	
E007		Main shaft motor-lock When large needle resistance sewing product is sewn	Turn OFF the power	
E018		Type of EEPROM is wrong. When the type of mounted EEPROM is wrong	Turn OFF the power.	
E023		Detection of step-out of presser lifting motor When step-out of motor is detected at the time when presser lifting motor passes origin sensor or starts operation.	Possible to re-start after pressing reset key.	Standard screen
E024		Pattern data size over When sewing cannot be performed since total size of continuous stitching data or size of downloaded data is too large.	Possible to re-start after pressing reset key.	Standard screen
E025		Detection of step-out of needle thread trimmer motor When step-out of motor is detected at the time when needle thread trimmer motor passes origin sensor or starts operation.	Possible to re-start after pressing reset key.	Standard screen
E026		Detection of step-out of bobbin thread trimmer motor When step-out of motor is detected at the time when bobbin thread trimmer motor passes origin sensor or starts operation.	Possible to re-start after pressing reset key.	Standard screen
E030		Needle bar upper position failure When needle does not stop at UP position even with needle UP operation at the time of starting sewing machine.	Possible to re-start after pressing reset key.	Standard screen
E050		Stop switch When stop switch is pressed during machine running.	Possible to re-start after pressing reset key.	Step screen
E052		Thread breakage detection error When thread breakage has occurred during machine running.	Possible to re-start after pressing reset key.	Step screen.
E061		Memory switch data error When memory switch data is broken or revision is old.	Turn OFF the power.	
E062		Sewing data error When sewing data is broken or revision is old.	Turn OFF the power.	
E099		Interference of knife lowering command with thread trimming motion When inserting position of knife command is improper and knife command interferes with thread trimming motion in case of motion by data from external input device.	Possible to re-start after pressing reset key.	Standard screen
E302		Confirmation of tilt of machine head When tilt of machine head sensor is OFF.	Possible to re-start after pressing reset key.	Standard screen
E303		Z phase sensor error of main shaft motor Z phase sensor of sewing machine motorencoder is abnormal.	Turn OFF the power.	
E304		Cloth cutting knife sensor error When sensor is not OFF while knife is lowered.	Turn OFF the power.	
E486		Eyelet knife length error Eyelet knife length is too short to form the shape in case of eyelet shape.	Possible to re-enter after pressing reset key.	Sewing data edit screen [S17] Eyelet knife length
E487		Eyelet shape length error Eyelet shape length is too short to form the shape in case of eyelet shape.	Possible to re-enter after pressing reset key.	Sewing data edit screen [S14] Eyelet shape length
E488		Taper bar-tacking compensation error When bar-tacking length is too short to form the shape in case of taper bar-tacking shape.	Possible to re-enter after pressing reset key.	Sewing data edit screen [S08] 2nd bar-tacking length

8. ERROR CODE LIST

Error code		Description	How to recover	Place of recovery
E489		Knife size error (at the time of plural motions of knife) When knife size is larger than cloth cutting knife size.	Possible to re-enter after pressing reset key.	Sewing data edit screen [S02] Cloth cut length
E492		Presser size over of basting When stitching data of basting exceeds presser size.	Possible to re-enter after pressing reset key.	Sewing data edit screen [S40] Basting needle entry compensation
E493		Presser size over of tie stitching at sewing end When stitching data of tie stitching at sewing end exceeds presser size.	Possible to re-enter after pressing reset key.	Sewing data edit screen [S67] Tie stitching at sewing end width
E494		Presser size over of tie stitching at sewing start When stitching data of tie stitching at sewing start exceeds presser size.	Possible to re-enter after pressing reset key.	Sewing data edit screen [S64] Tie stitching at sewing start width
E495		Presser size error (Width direction : right only) When stitching data exceeds the size of right only of width direction of presser.	Possible to re-enter after pressing reset key.	Sewing data edit screen [S03] Knife groove width, right or [S06] Ratio of right and left shapes
E496		Presser size error (Width direction : left only) When stitching data exceeds the size of left only of width direction of presser.	Possible to re-enter after pressing reset key.	Sewing data edit screen [S04] Knife groove width, left or [S06] Ratio of right and left shapes
E497		Presser size error (Length direction : front) When stitching data exceeds the size of front of length direction of presser.	Possible to re-enter after pressing reset key.	Standard screen
E498		Presser size error (Width direction : right and left) When stitching data exceeds the size of both right and left of width direction of presser.	Possible to re-enter after pressing reset key.	Sewing data edit screen [S05] Overedging width, left
E499		Presser size error (Length direction : rear) When stitching data exceeds the size of rear of length direction of presser.	Possible to re-enter after pressing reset key.	Sewing data edit screen [S02] Cloth cut length
E703		Panel is connected to the machine other than supposed. (Machine type error) When machine type code of system is improper in case of initial communication.	Turn OFF the power.	
E704		Nonagreement of system version When version of system software is improper in case of initial communication.	Turn OFF the power.	
E730		Main shaft motor encoder defectiveness or phase-out When encoder of sewing machine motor is abnormal.	Turn OFF the power.	
E731		Main motor hole sensor defectiveness or position sensor defectiveness When hole sensor or position sensor of sewing machine motor is defective.	Turn OFF the power.	
E733		Reverse rotation of main shaft motor When sewing machine motor rotates in reverse direction.	Turn OFF the power.	
E801		Phase-lack of power When phase-lack of input power occurs.	Turn OFF the power.	
E802		Power instantaneous cut detection When input power is instantaneously OFF.	Turn OFF the power.	
E811		Overvoltage When input power is 280V or more.	Turn OFF the power.	
E813		Low voltage When input voltage is 150V or less.	Turn OFF the power.	
E901		Abnormality of main shaft motor IPM When IPM of servo control p.c.b. is abnormal.	Turn OFF the power.	
E902		Overcurrent of main shaft motor When current flows excessively to sewing machine motor.	Turn OFF the power.	

8. ERROR CODE LIST

Error code		Description	How to recover	Place of recovery
E903		Abnormality of stepping motor power When stepping motor power of servo control p.c.b. fluctuates $\pm 15\%$ or more.	Turn OFF the power.	
E904		Abnormality of solenoid power When solenoid power of servo control p.c.b. fluctuates $\pm 15\%$ or more.	Turn OFF the power.	
E905		Abnormality of temperature of heat sink for servo control p.c.b. When temperature of heat sink of servo control p.c.b. is 85°C or more.	Turn OFF the power	
E907		Stitch width motor origin retrieval error When origin sensor signal is not inputted at the time of origin retrieval motion.	Turn OFF the power.	
E908		Y feed motor origin retrieval error When origin sensor signal is not inputted at the time of origin retrieval motion.	Turn OFF the power	
E909		Needle thread trimmer motor origin retrieval error When origin sensor signal is not inputted at the time of origin retrieval motion.	Turn OFF the power.	
E910		Presser motor origin retrieval error When origin sensor signal is not inputted at the time of origin retrieval motion.	Turn OFF the power	
E911		Bobbin thread trimmer motor origin retrieval error When origin sensor signal is not inputted at the time of origin retrieval motion.	Turn OFF the power.	
E915		Abnormality of communication between operation panel and main CPU When abnormality occurs in communication.	Turn OFF the power	
E916		Abnormality of communication between main CPU and main shaft CPU When abnormality occurs in communication.	Turn OFF the power.	
E918		Abnormality of temperature of heat sink for main control p.c.b. When temperature of heat sink of main control p.c.b. is 85°C or more.	Turn OFF the power	
E943		Defectiveness of EEP-ROM of main control p.c.b When data writing to EEP-ROM is not performed.	Turn OFF the power.	
E946		Defectiveness of writing to EEP-ROM of head relay p.c.b. When data writing to EEP-ROM is not performed.	Turn OFF the power	
E999		When cloth cutting knife does not return <ul style="list-style-type: none"> • When cloth cutting knife does not return after the lapse of predetermined time. • When sensor is not turned ON while cloth cutting knife is raising (at the time of waiting). 	Turn OFF the power	

9. TROUBLES AND CORRECTIVE MEASURES

9.TROUBLES AND CORRECTIVE MEASURES

Troubles	Causes	Corrective measures	Page
1. Needle thread breakage	<ol style="list-style-type: none"> 1. Thread tension at parallel section is too high. 2. Pressure or stroke of thread take-up spring is too large. 3. There is a burr or scratch on the blade point of hook. 4. Hook timing is not proper. 5. There is a scratch on the thread path. 6. Attaching needle is wrong. 7. Needle is too thin. 8. Needle tip is damaged. 	<ul style="list-style-type: none"> ○ Decrease the thread tension at parallel section. ○ Decrease the tension of thread take-up spring or decrease its stroke. ○ Buff the blade point of hook. Or, replace the hook. ○ Adjust again the hook timing with timing gauge. ○ Polish the thread path with sand paper and buff it. ○ Adjust again the direction, height, etc. ○ Replace the needle with a thicker one. ○ Replace the needle. 	<p>P.22</p> <p>P.51</p> <p>–</p> <p>P.48</p> <p>–</p> <p>P.12</p> <p>–</p> <p>–</p>
2. Needle thread slips off.	<ol style="list-style-type: none"> 1. Needle thread trimmer opens too early. 2. Whip stitching is not formed at the start of sewing. (Tension at the start of sewing is too high.) 3. Threading needle thread is wrong. 4. Speed at the start of sewing is too fast. 	<ul style="list-style-type: none"> ○ Delay the opening timing of the needle thread trimmer. ○ Decrease tension at the start of sewing. ○ Thread properly again. ○ Set the soft-start function. 	<p>P.49</p> <p>P.32</p> <p>P.13</p> <p>P.44</p>
3. Wobbling at parallel section	<ol style="list-style-type: none"> 1. Thread tension at parallel section is too low. 2. Bobbin thread tension is too high. 3. Pre-tension is too low. 	<ul style="list-style-type: none"> ○ Increase the thread tension at parallel section. ○ Decrease bobbin thread tension. (Purl stitching : 0.05 to 0.1N) ○ Increase pre-tension. 	<p>P.22</p> <p>P.14</p> <p>–</p>
4. Wobbling at the start of sewing	<ol style="list-style-type: none"> 1. Thread tension at parallel section is too low. 2. Position of needle thread trimmer is too high. 3. Stroke of thread take-up spring is too large. 	<ul style="list-style-type: none"> ○ Increase the thread tension at parallel section. ○ Lower the needle thread trimmer to such an extent that it does not come in contact with the presser. ○ Decrease the stroke of thread take-up spring. 	<p>P.22</p> <p>P.49</p> <p>P.51</p>
5. Needle thread appears on the wrong side of material at bar-tacking section in dumpling condition.	<ol style="list-style-type: none"> 1. Bar-tacking thread tension is too low. 2. Bobbin thread tension is too high. 3. Number of stitches of radial shape is too many. 4. Tension at the end of sewing is too low. 	<ul style="list-style-type: none"> ○ Increase the bar-tacking thread tension. ○ Decrease the bobbin thread tension. (0.05 to 0.1N) ○ Decrease the number of stitches. ○ Increase tension at the end of sewing. 	<p>P.22</p> <p>P.14</p> <p>P.30</p> <p>P.44</p>
6. Stitches float.	<ol style="list-style-type: none"> 1. Bobbin thread tension is too low. 2. Bobbin thread comes off bobbin case. 	<ul style="list-style-type: none"> ○ Increase the bobbin thread tension. ○ Perform proper threading the bobbin case. ○ Take care that the winding amount of bobbin thread is not excessive. 	<p>P.14</p> <p>P.13</p> <p>P.24</p>
7. Stitch skipping	<ol style="list-style-type: none"> 1. Button hole is small in terms of the size of presser. 2. Material flops because of light-weight. 3. Attaching needle is wrong. 4. Needle is bent. 5. There is a burr or scratch on the blade point of hook. 	<ul style="list-style-type: none"> ○ Replace the presser with a smaller one. ○ Delay the hook-to-needle timing. (Lower the needle bar by 0.5 mm.) ○ Adjust again the direction, height, etc. ○ Replace the needle. ○ Buff the blade top of hook. Or, replace the hook. 	<p>–</p> <p>P.48</p> <p>P.12</p> <p>–</p> <p>–</p>
8. Thread frays.	<ol style="list-style-type: none"> 1. Number of stitches of tie stitching is too small. 2. Width of tie stitching is too wide. 	<ul style="list-style-type: none"> ○ Increase the number of stitches of tie stitching at the end of sewing. ○ Narrow the width of tie stitching at the end of sewing. 	<p>P.33</p> <p>P.33</p>
9. Length of needle thread remaining at the end of sewing is too long.	<ol style="list-style-type: none"> 1. Width of tie stitching is too narrow. 2. Tension of tie stitching is too low. 	<ul style="list-style-type: none"> ○ Widen the width of tie stitching at the end of sewing. ○ Increase tension at the end of sewing. 	<p>P.33</p> <p>P.44</p>

9. TROUBLES AND CORRECTIVE MEASURES

Troubles	Causes	Corrective measures	Page
10. Needle thread breaks at the start of sewing, or the wrong side of seam is dirty.	1. Tension at the start of sewing is too low.	① Increase tension at the start of sewing.	P.32
11. Knife drops even when needle thread is cut.	1. Check whether the thread breakage detector plate is properly adjusted.	① Adjust the detector plate. (Refer to the Engineer's Manual.)	—
12. Needle breaks.	<ol style="list-style-type: none"> 1. Check whether needle is bent. 2. Check whether needle comes in contact with the blade point of hook. 3. Check whether needle thread trimmer comes in contact with needle when it opens. 4. Check whether needle comes in the center of the needle hole of throat plate. 5. Needle stop position is too low and needle comes in contact with needle thread trimmer when it closes. 	<ol style="list-style-type: none"> ① Replace the needle. ② Adjust the needle-to-hook timing. ③ Adjust the installing position of needle thread trimmer. ④ Re-adjust the installing position of throat plate base. 	P.13 P.48 P.49 —
13. Knife drops plural times.	1. Check whether the cloth cutting knife dropping is set to plural dropping.	① Release the plural time setting.	P.42



富山IoT



微信公众号



抖音官方号

上海富山精密机械科技有限公司

HIKARI (SHANGHAI) PRECISE MACHINERY SCIENCE AND TECHNOLOGY CO., LTD

邮箱/E-mail: hikari@chinahikari.com

网址/Web: www.chinahikari.com

传真/Fax: (00)86-21-67311311

电话/Tel: (00)86-21-67311111 (转外贸部/ext .Foreign Trade Dept)

上海市金山区朱泾镇工业园区中达路800号

NO.800, ZHONGDA ROAD, ZHUJING INDUSTRIAL ZONE,

JINSHAN DISTRICT, SHANGHAI CHINA



QUANTITY ATTESTATION
ISO9001质量体系认证