

1、机壳部件/Machine frame&miscellaneous cover components

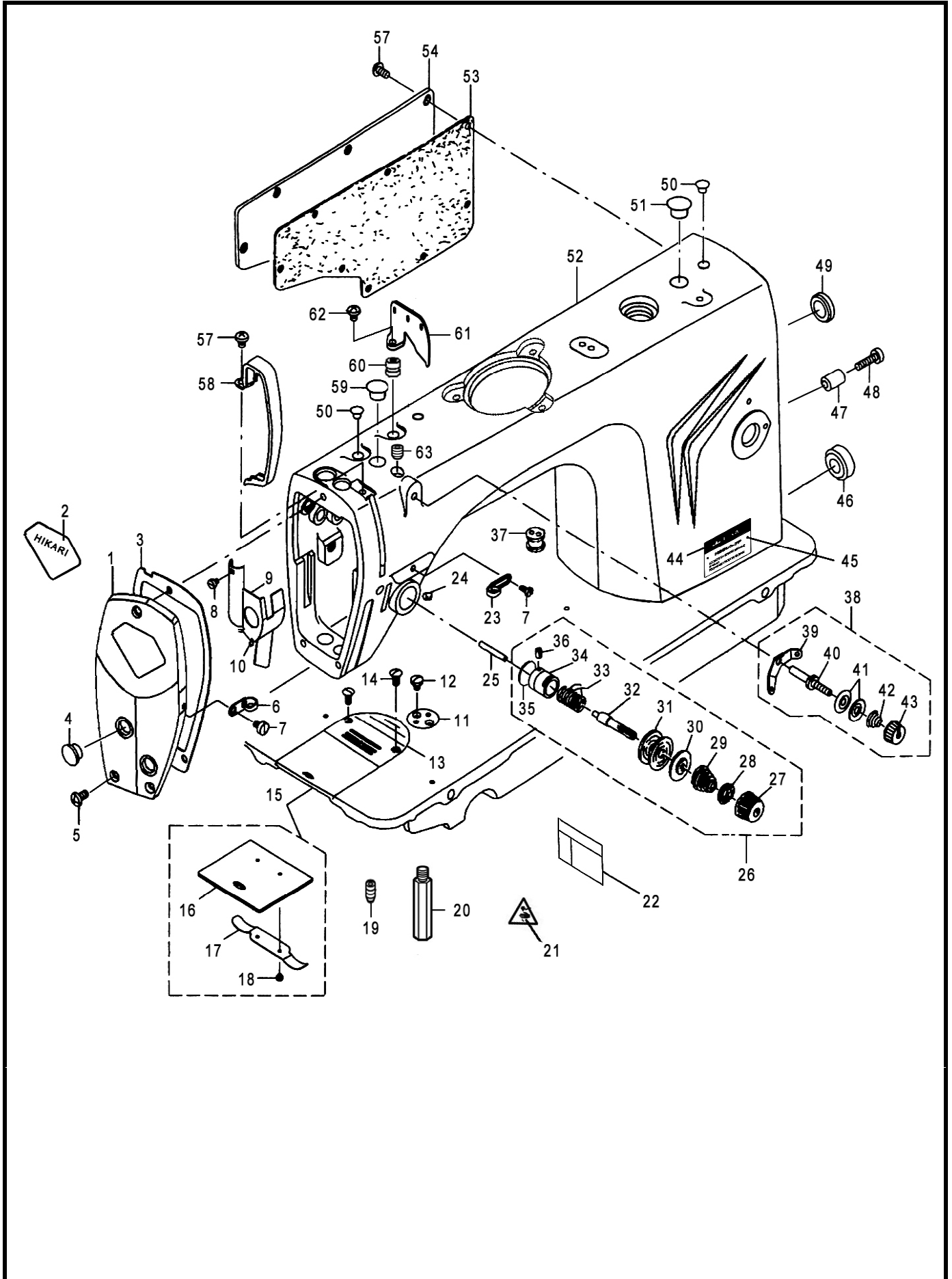

1、机壳部件/Machine frame&miscellaneous cover components

序号 Ref.No	图号 Part. No	零件名称	Name of parts	数量Qty		
				H8800DF -7C-5	H8800D -7C-5	H8800DH -7C-5
1	122.01-01	机头面板	Plate	1		
2	102.01-01-01G	面板贴	Plate stick	1		
3	102.01-02G	面板垫	Plate agsket	1		
4	22-12404016	面板孔塞 $\phi 12.4 \times 4 \times \phi 16$	Rubber plug	2		
5	02-412281223-1	螺钉 SM3/16x28x12	Screw	3		
6	101.01-32	左线钩	Arm thread guide Left	1		
7	02-611400621-1	螺钉 SM11/64x40x6	Screw	2		
8	02-608440421-1	螺钉 SM1/8x44x4	Screw	1		
9	102.01-04-01	面板防油板	Anti-oil plate	1		
10	101.01-04-02	面板防油板油线	Oil wick	1		
11	102.01-61	卷边器座	Ruler stopper	1		
12	02-911400621-1	螺钉 SM11/64x40x6	Screw	2		
13	110.01-44	针板	Throat plate		1	
	110.01-44-014	针板	Throat plate	1		
	116.01-45A	针板	Throat plate			1
14	02-211400823-1	针板螺钉 SM11/64x40x8	Screw	2		
15	101.01-46	推板组件	Slide plate asm.	1		
16	101.01-46-01	推板	Slide plate	(1)		
17	101.01-46-02	推板簧	Bed slide spring	(1)		
18	02-606560221-3	螺钉 SM3/32x56x2	Screw	(2)		
19	02-808440624-1	螺钉 SM1/8x44x6	Screw	1		
20	101.01-37	底板支柱	Bed screw stud	4		
21	201.02-10	安全指示牌	Safety lable	1		
22	101.01-13	安全指示牌	Safety lable	1		
23	101.01-25	右线钩	Arm thread guide Right	1		
24	02-815281211-1	螺钉 SM15/64x28x12	Screw	1		
25	101.01-27-10	松线钉	Tension releasing	1		
26	101.01-27	夹线器组件	Thread tension asm.	1	1	
	116.01-27	夹线器组件	Thread tension asm.			1
27	101.01-27-01	夹线螺母	Tension nut	(1)		
28	101.01-27-02	夹线制动板	Rotating stopper	(1)		
29	101.01-27-03	夹线簧	Tension spring	(1)	(1)	
	114.09-01-01	夹线簧	Tension spring			(1)
30	101.01-27-04	松线板	Thread tension disk presser	(1)		
31	101.01-27-05	夹线板	Thread tension disk	(2)		
32	101.01-27-06	夹线螺钉	Tension post	(1)		
33	101.01-27-07	挑线簧	Take-up spring	(1)	(1)	
	116.01-27-07	挑线簧	Take-up spring			(1)
34	101.01-27-09	挑线簧调节座	Tension post socket	(1)		
35	12-137160	O型圈 $\phi 13.7 \times \phi 1.6$	Rubber ring	(1)		
36	02-909400421-1	螺钉 SM9/64x40x4	Screw	(1)		
37	101.01-20A	导线过线套	Rubber plug	1		
38	110.01-21	调线夹线器组件	Thread tension asm.	1		
39	110.01-21-01G	调线夹线螺钉	Thread tension post	(1)		
40	110.01-23G	调线过线板	Thread tension guide	(1)		
41	101.01-21-03	小夹线板	Thread tension disk	(2)		

1、机壳部件/Machine frame&miscellaneous cover components

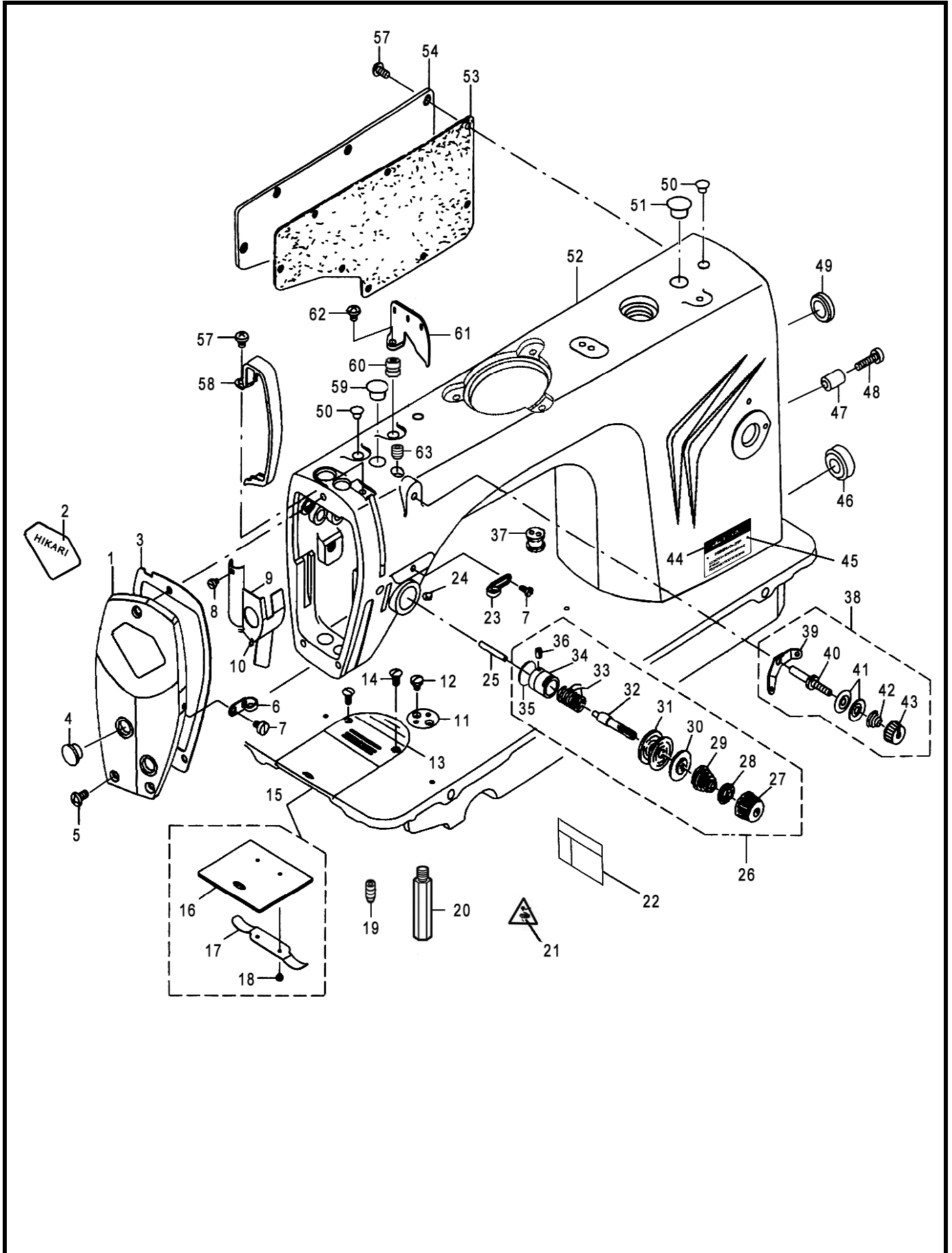

1、机壳部件/Machine frame&miscellaneous cover components

序号 Ref.No	图号 Part. No	零件名称	Name of parts	数量Qty		
				H8800DF -7C-5	H8800D -7C-5	H8800DH -7C-5
42	101.01-21-04	小夹线簧	Thread tension spring	(1)		
43	101.01-21-05	小夹线螺母	Thread tension nut	(1)		
44	102.01-64G	型号牌	Model plate	1		
45	17-3200500-5	型号牌铆钉	Pole	2		
46	22-20611000	下轴盲孔塞 φ20.6x11	Rubber plug	1		
47	102.01-18	倒送料扳手定位套	Reverse feed lever stopper	1		
48	02-512321821-1	螺钉 SM3/16x32x18	Screw	1		
49	22-20012000	送料调节器孔塞φ20×12	Rubber plug	1		
50	22-08506011	孔塞 φ8.5x6xφ10.5	Rubber plug	2		
51	22-20809024	橡皮塞 φ20.8x9xφ23.5	Rubber plug	1		
52	124.01-01	机壳组件	Machine cover	1		
53	102.01-11	后窗板垫	Gasket	1		
54	102.01-10	后窗板	Side plate	1		
57	02-412280923-1	螺钉 SM3/16x28x9	Screw	6		
58	101.01-23G	挑线杆防护罩	Thread take-up lever cover	1		
59	22-12507017	孔塞 φ12.5x7xφ17	Rubber plug	1		
60	110.01-83	过线板定位螺套		1		
61	110.01-07	面线过线板	Spool pin	1		
62	01-404001023-1	过线套定位螺钉M4x10		1		
63	01-805000814-1	螺钉 M5x8	Screw	1		

2、上轴·挑线部件/Main shaft&Thread take-up lever components

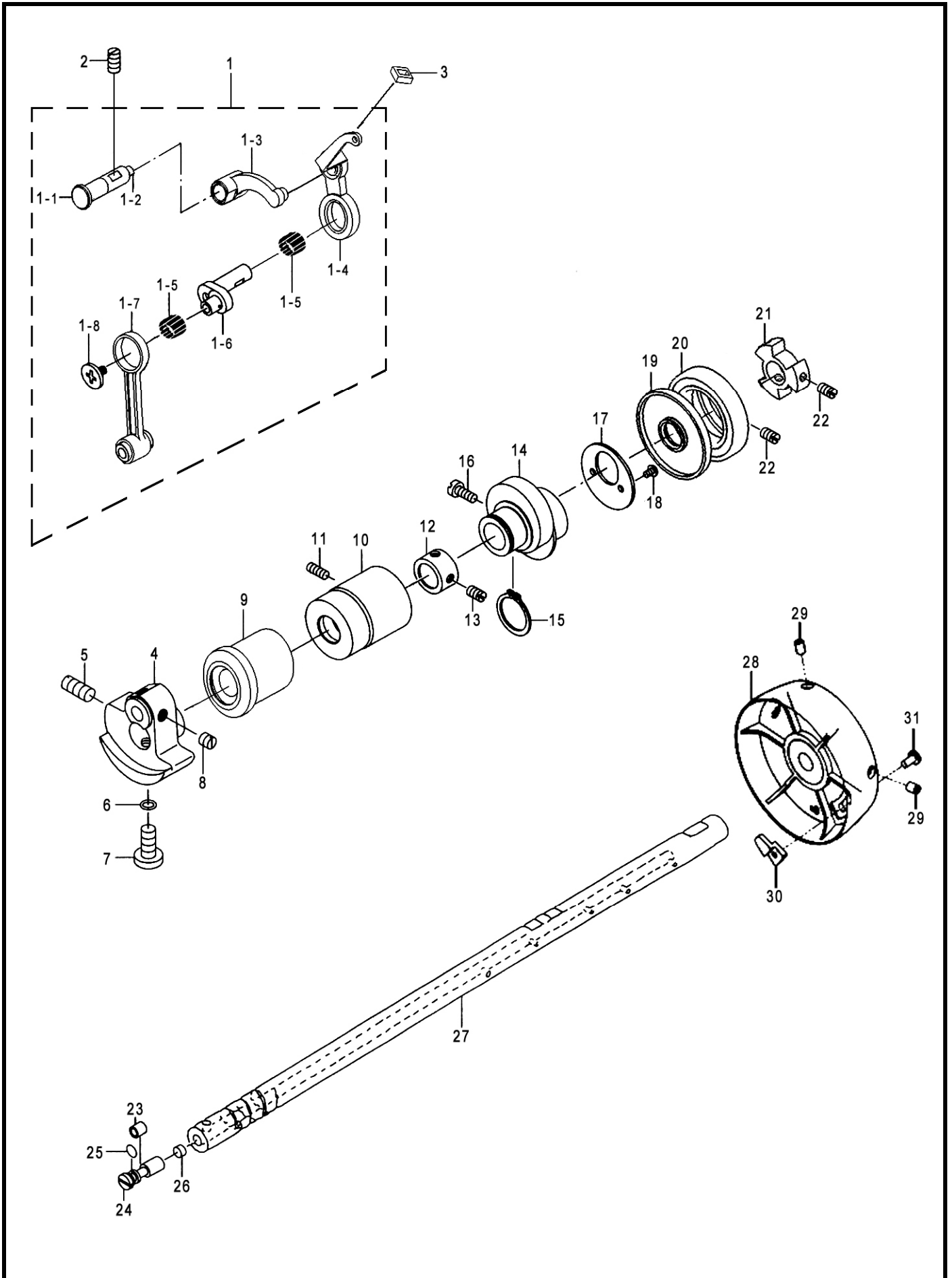

2、上轴·挑线部件/Main shaft&Thread take-up lever components

序号 Ref.No	图号 Part. No	零件名称	Name of parts	数量Qty		
				H8800DF -7C-5	H8800D -7C-5	H8800DH -7C-5
1	101.02-04	挑线杆大组件	Thread take-up lever big asm.	1	1	
	116.02-04	挑线杆大组件	Thread take-up lever big asm.			1
1-1	101.02-02	挑线连杆销	Thread take-up crank shaft	(1)		
1-2	101.02-03	挑线连杆销油线	Roller felt	(1)		
1-3	101.02-04-02	挑线连杆	Thread take-up lever	(1)	(1)	
	116.02-04-02	挑线连杆	Thread take-up lever			(1)
1-4	101.02-04-01	挑线杆组件	Thread take-up lever asm.	(1)	(1)	
	116.02-04-01	挑线杆组件	Thread take-up lever asm.			(1)
1-5	14-0081208-0	挑线杆滚针轴承	Thread take-up bearing	(2)		
1-6	101.02-04-04	挑线曲柄	Crank	(1)	(1)	
	116.02-04-04	挑线曲柄	Crank			(1)
1-7	101.02-04-05	针杆连杆	Needle bar crank rod	(1)		
1-8	101.02-04-06	左旋挑线曲柄螺钉	Left screw	(1)		
2	02-815281151-1	螺钉 SM15/64x28x11	Screw	1		
3	101.02-05	橡皮套	Rubber	1		
4	102.02-15A	针杆曲柄	Needle bar crank	1		
5	02-818281651-1	螺钉 SM9/32x28x16	Screw	1		
6	12-060200	O型圈 φ6xφ2.0	Rubber ring	1		
7	02-418281531-1	螺钉 SM9/32x28x15	Screw	1		
8	02-816400611-1	螺钉 SM1/4x40x6	Screw	2		
9	101.02-19	上轴前轴套	Main shaft front bushing	1		
10	102.02-27	上轴中轴套	Bushing,intermediate	1		
11	02-815280714-1	螺钉 SM15/64x28x7	Screw	1		
12	102.02-23	上轴挡圈	Collar	1		
13	02-816400811-1	螺钉 SM1/4x40x8	Screw	2		
14	101.02-12	送料偏心轮	Feed drive eccentric cam	1	1	
	116.02-12D	送料偏心轮	Feed drive eccentric cam			1
15	10-1851320-1	挡圈 φ18.5x1.3	Snap ring	1		
16	02-516401111-1	螺钉 SM1/4x40x11	Screw	2		
17	101.02-32	送料偏心轴盖板	Thrust collar	1		
18	02-209400821-1	螺钉 SM9/64x40x8	Screw	2		
19	13-14170550	上轴油封 φ14.1x7xφ55	Oil seal	1		
20	14-6907-2RS/1/14.72	联体轴承	Bearing	1		
21	260.04-44	连轴器(1)	Linker(1)	1		
22	01-806750814-1	螺钉 M6x0.75x8	Screw	6		
23	101.02-21	曲柄油量调节套	Oil adjusting pin	1		
24	101.02-29	上轴油量调节销	Oil amount adjusting pin	1		
25	12-025180	O型圈φ2.5xφ1.8	Rubber ring	1		
26	101.02-31	曲柄油量限制毡	Roller felt	1		
27	102.02-38G	上轴	Main shaft	1		
28	102.02-34G1-00	手轮组件	Hand wheel	1		
29	02-815281014-1	螺钉 SM15/64x28x10	Screw	2		
30	103.13-107	磁钢	Magnets	1		
31	18-404000823-3	磁钢固定螺钉 M4x8	Screw	1		

3、针杆·竖轴·下轴部件/Needle bar, upright shaft & hook driving shaft components

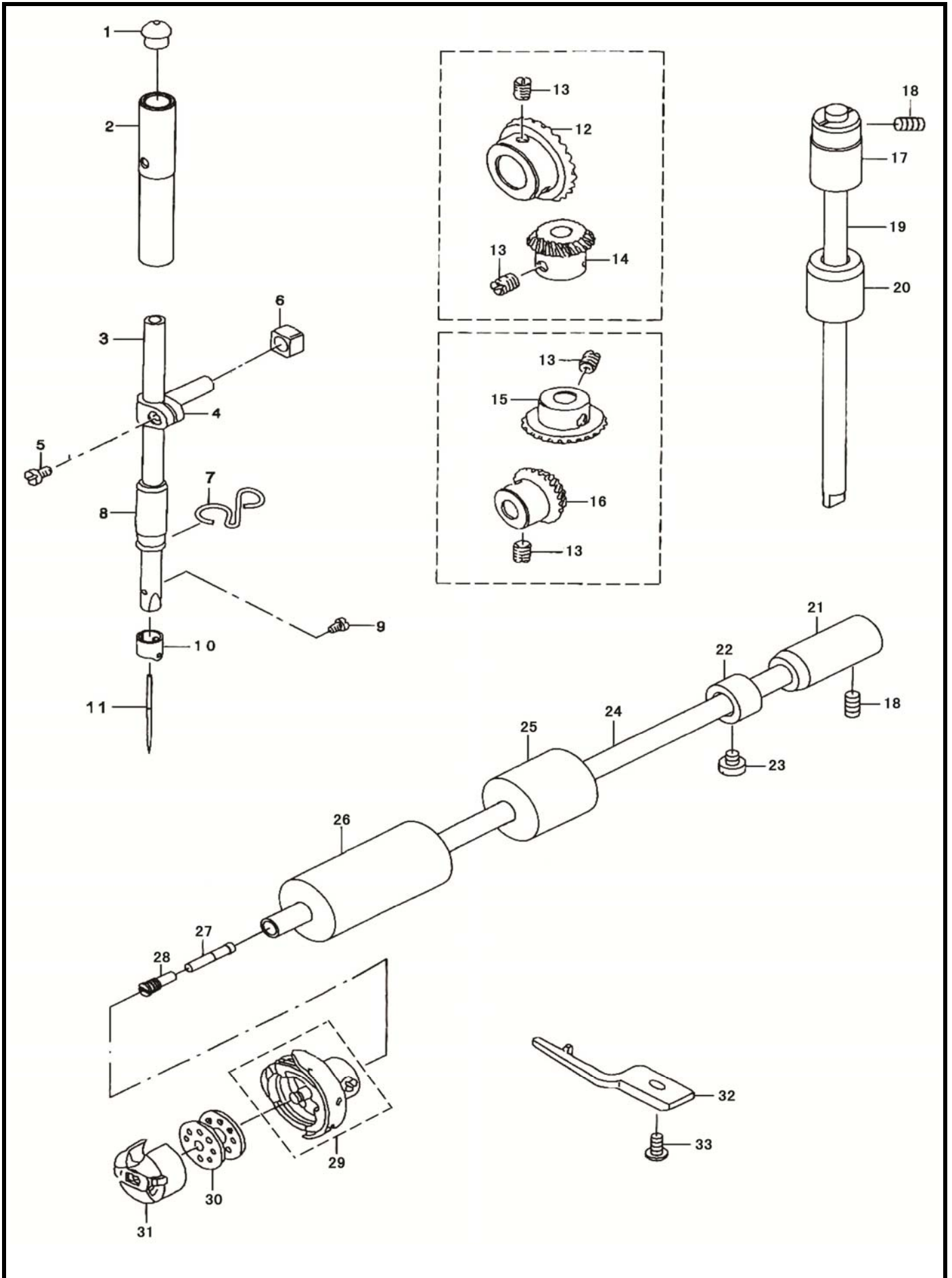

3、针杆·竖轴·下轴部件/Needle bar,upright shaft&hook driving shaft components

序号 Ref.No	图号 Part. No	零件名称	Name of parts	数量Qty		
				H8800DF -7C-5	H8800D -7C-5	H8800DH -7C-5
1	22-08506511	橡胶塞 φ8.5x6.5xφ10.5	Cap	1		
2	101.03-02	针杆上套	Needle bar bushing (upper)	1		
3	101.03-03	针杆	Needle bar	1	1	
	101.13-10	针杆	Needle bar			1
4	102.03-04A	针杆连接柱	Needle rod holder	1		
5	02-509400721-1	螺钉 SM9/64x40x7	Screw	1		
6	102.03-06A	针杆连接柱滑块	Slide block	1		
7	101.03-07	针杆下套线钩	Needle bar thread guide	1	1	
	101.13-08	针杆下套线钩	Needle bar thread guide			1
8	101.03-08	针杆下套	Needle bar bushing (lower)	1	1	
	101.13-09	针杆下套	Needle bar bushing (lower)			1
9	02-508440521-1	螺钉 SM1/8x44x5	Screw	1		
10	101.03-10	针杆线钩	Needle bar thread guide	1		
11	101.03-11	机针	Needle	1	1	
	101.12-11-24	机针(DPX5 22#)	Needle(DPX5 22#)			1
12	102.03-12	上轴伞齿轮	Conical gear	1		
13	02-816400711-1	螺钉 SM1/4x40x7	Screw	8		
14	102.03-14	竖轴上伞齿轮	Conical gear	1		
15	102.03-16	竖轴下伞齿轮	Gear	1		
16	102.03-18	下轴伞齿轮	Conical gear	1		
17	101.03-21	竖轴上轴套	Upright shaft bushing (upper)	1		
18	02-815280814-1	螺钉 SM15/64x28x8	Screw	2		
19	101.03-20	竖轴	Upright shaft	1		
20	101.03-23	竖轴下轴套	Upright shaft bushing (lower)	1		
21	101.03-24	下轴后轴套	Bushing rear	1		
22	101.03-26	下轴挡圈	Thrust collar	1		
23	02-511400511-1	螺钉 SM11/64x40x5	Screw	2		
24	102.03-31	下轴	Lower shaft	1		
25	122.03-46	下轴中轴套	Bushing (intermediate)	1		
26	102.03-35	下轴前轴套	Lower shaft bushing	1		
27	101.03-35	下轴限油芯	Oil wick	1		
28	102.03-40	下轴限油螺钉	Oil seal screw	1		
29	101.03-36-04	旋梭	Hook	1	1	
	116.03-37	旋梭	Hook			1
30	101.03-37-02	梭心	Bobbin	1		
31	122.03-37-02	梭壳	Bobbin case	1		
32	108.07-14	旋梭定位钩	Bobbin case holder	1		
33	02-511401221-1	螺钉 SM11/64x40x12	Screw	1		

4、压杆部件/Hand lifter components

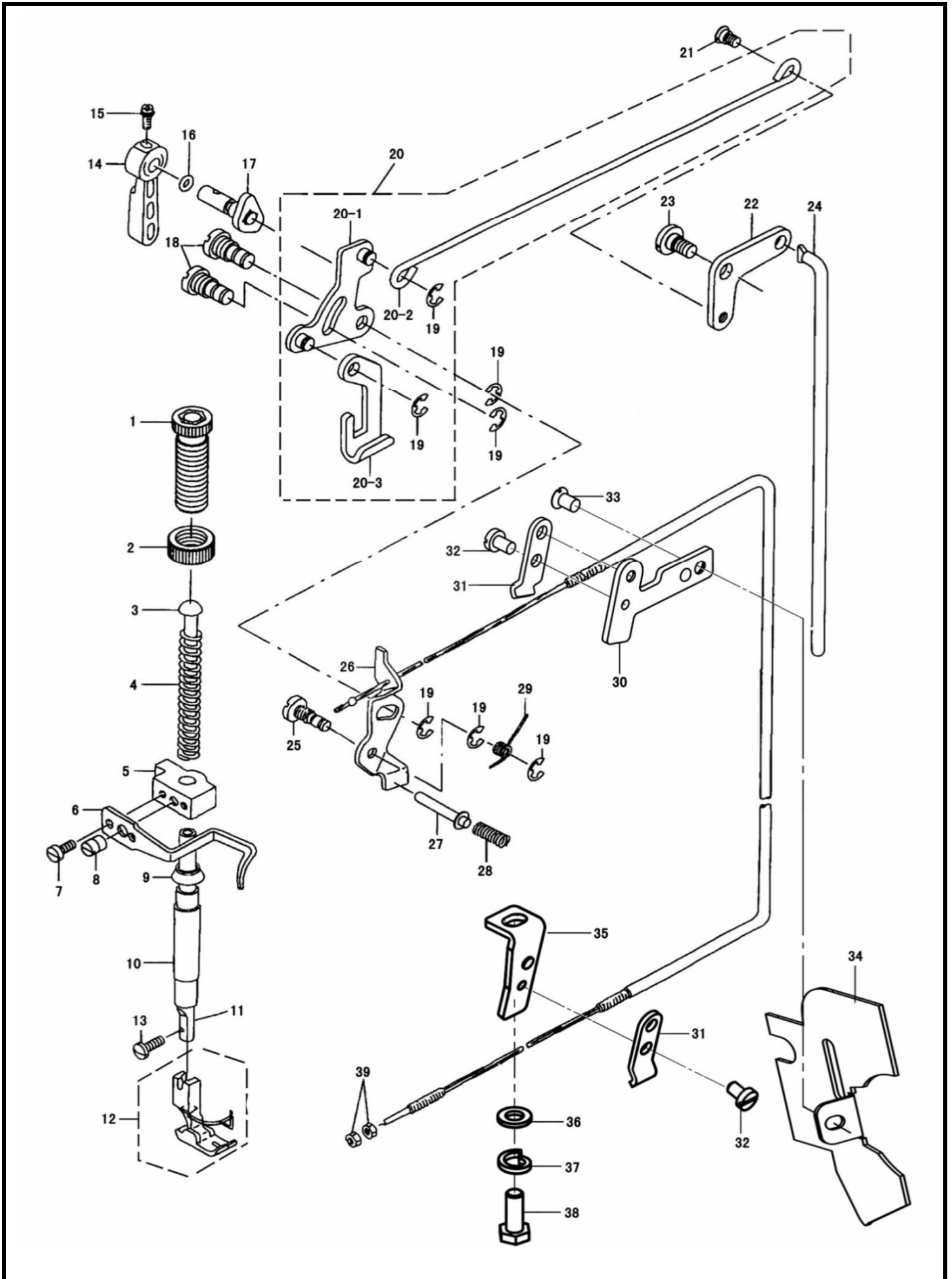

4、压杆部件/Hand lifter components

序号 Ref.No	图号 Part. No	零件名称	Name of parts	数量Qty		
				H8800DF -7C-5	H8800D -7C-5	H8800DH -7C-5
1	101.04-32	调压螺钉	Presser spring regulator	1		
2	101.04-31	调压螺母	Presser adjusting screw nut	1		
3	101.04-40	调压导杆	Presser guide bar	1		
4	101.04-33	调压簧	Presser adjusting spring	1		
5	101.04-34	压杆导架	Presser bar guide bracket	1		
6	102.04-36	缓线调节钩	Presser bar thread guide	1		
7	02-509400721-1	螺钉 SM9/64x40x7	Screw	2		
8	02-816400811-1	螺钉 SM1/4x40x8	Screw	1		
9	101.04-41	防油伞	Rubber	1		
10	101.04-05	压杆轴套	Presser bar bushing	1		
11	101.04-35	压杆	Presser bar	1		
12	101.04-09	活压脚组件	Presser foot asm.	1	1	
	116.04-10	活压脚组件	Presser foot asm.			1
13	02-509401021-1	螺钉 SM9/64x40x11	Screw	1		
14	101.04-01	压脚扳手	Hand lifter	1		
15	19-409401023-1	螺钉 SM9/64x40x10	Screw	1		
16	12-038180	O型圈 $\phi 3.8 \times \phi 1.8$	Rubber ring	1		
17	101.04-04	压脚扳手凸轮组件	Hand lifter cam asm.	1		
18	102.04-07	前杠杆螺纹销	Link shaft	2		
19	06-0500611-1	开口挡圈 $\phi 5 \times \phi 11 \times 0.6$	E-ring	7		
20	101.04-39	前杠杆组件	Knee lifting cross rod asm.	1		
20-1	101.04-39-01	抬压脚前杠杆小组件	Hand lifter link asm.	1		
20-2	101.04-39-05	抬压脚拉杆	Knee lifting cross rod	1		
20-3	101.04-39-03	压脚升降板	Lifting lever	1		
21	101.04-11	抬压脚拉杆螺钉	Hinge screw	1		
22	101.04-14	抬压脚后杠杆	Lifting lever link	1		
23	101.04-12	后杠杆轴位螺钉	Hinge screw	1		
24	101.04-13	抬压脚顶杆	Knee lifter connecting rod	1		
25	102.04-29	松线顶板螺纹销	Tension release pin	1		
26	102.04-28	松线顶板组件	Thread tension release asm.	1		
27	102.04-26	松线辅钉	Supporting pin	1		
28	101.04-24	松线辅钉弹簧	Thread release pin spring	1		
29	101.04-23	松线顶板复位簧	Tension release return spring	1	1	
	116.04-23	松线顶板复位簧	Tension release return spring			1
30	102.04-20	上压线底板	Wire holder bracket (upper)	1		
31	101.04-18	拉线活压板	Wire holder	2		
32	02-511400721-1	螺钉 SM11/64x40x7	Screw	2		
33	02-112280821-1	螺钉 SM3/16x28x8	Screw	1		
34	102.03-17	挡油板	Break oil	1		
35	102.04-10	松线导管下支架	Wire holder bracket (lower)	1		
36	05-064161200-1	平垫片 $\phi 6.4 \times 1.6 \times \phi 12$	Washer	1		
37	07-0631616-1	弹垫 $\phi 6.3 \times 1.6 \times 1.6$	Spring washer	1		
38	02-715281521-1	螺钉 SM15/64x28x15	Screw	1		
39	04-612320400-1	螺母 SM3/16x32x4	Nut	2		

5、送料部件/Feed mechanism components

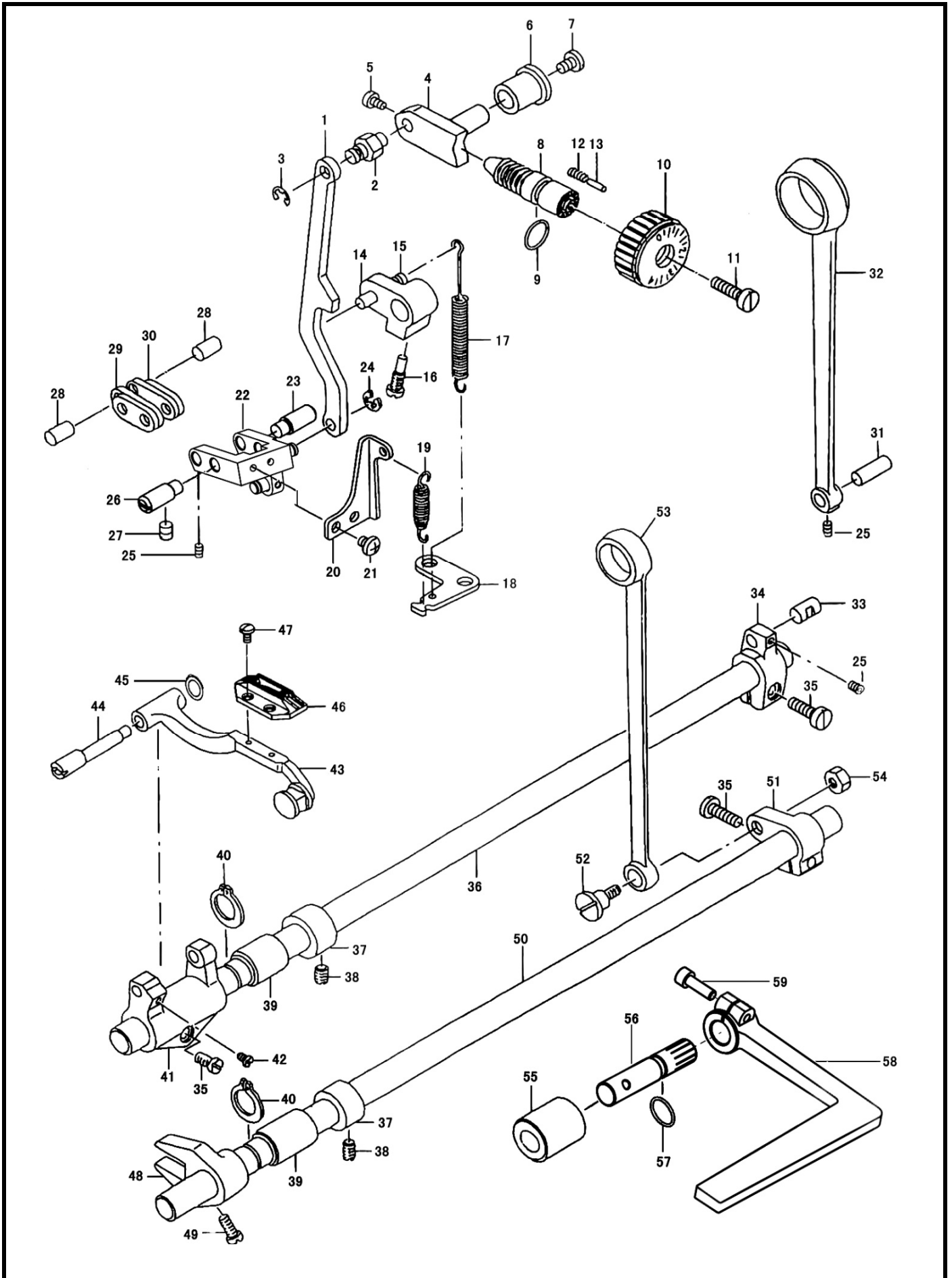

5、送料部件/Feed mechanism components

序号 Ref.No	图号 Part. No	零件名称	Name of parts	数量Qty		
				H8800DF -7C-5	H8800D -7C-5	H8800DH -7C-5
1	102.05-01G	倒送料连杆	Feed adjust rod	1		
2	102.05-02	倒送料连杆销	Feed regulator pin	1		
3	06-0601012-1	开口挡圈 $\phi 6 \times 1 \times \phi 12$	E-ring	1		
4	101.05-04	送料调节器	Feed regulator	1		
5	02-509400621-1	螺钉 SM9/64x40x6	Screw	2		
6	101.05-05	送料调节器轴套	Feed regulator bushing	1		
7	02-312280721-1	螺钉 SM3/16x28x7	Screw	1		
8	102.05-07	送料距调节螺栓	Feed regulator screw	1		
9	12-095265	O型圈 $\phi 9.5 \times \phi 2.65$	Rubber ring	1		
10	101.05-10	针距标盘	Feed dial	1	1	
	106.05-01	针距标盘	Feed dial			1
11	02-512281821-1	螺钉 SM3/16x28x18	Screw	1		
12	103.04-03	止动销弹簧	Spring	1		
13	102.05-09	送料距锁合销	Feed adjust pin	1		
14	102.05-19-01	倒送料曲柄	Feed reverse arm	1		
15	101.05-19-02	倒送料曲柄销	Pin	1		
16	02-516402031-1	螺钉 SM1/4x40x20	Screw	1		
17	102.05-17	倒送料拉簧	Feed reverse spring	1		
18	101.05-38	拉簧固定板	Feed spring hood	1		
19	101.05-17G	摆动板座复位簧	Spring	1		
20	101.05-36	摆动板座复位板	Adjusting link spring guide	1		
21	02-411400721-1	螺钉 SM11/64x40x7	Screw	2		
22	101.05-27A	摆动板座组件	Feed adjust link asm.	1		
23	102.05-28-01	摆动板座销钉(长)	Adjusting link fulcrum shaft p	1		
24	06-0500611-1	开口挡圈 $\phi 5 \times 0.6 \times \phi 11$	E-ring	1		
25	02-809400424-1	螺钉 SM9/64x40x4	Screw	4		
26	101.05-28	摆动板座销钉(短)	Adjusting link fulcrum shaft p	1		
27	02-815281151-1	螺钉 SM15/64x28x11	Screw	2		
28	101.05-24	短摆动板连接销	Walking foot short pin	2		
29	101.05-25	送料长摆动板	Connecting link long pin	2		
30	101.05-26	送料短摆动板	Connecting link short pin	2		
31	101.05-13	送料连杆销	Walking foot long pin	1		
32	101.05-12	送料连杆	Rocker shaft connecting rod	1	1	
	116.05-12	送料连杆	Rocker shaft connecting rod			1
33	101.05-40	送料曲柄销	Walking foot middle pin	1	1	1
34	101.05-43	送料曲柄	Feed rocker shaft crank	1	1	
	116.05-43	送料曲柄	Feed rocker shaft crank			1
35	02-412281423-1	螺钉 SM3/16x28x14	Screw	3		
36	101.05-39	送料轴	Feed rocker shaft	1		
37	101.02-17	上轴挡圈	Thrust collar	2		
38	02-816400514-1	螺钉 SM1/4x40x5	Screw	4		
39	101.05-51A	送料轴前轴套	Feed rocker shaft bushing	2		
40	10-1381017-1	轴用挡圈 $\phi 13.8 \times 1$	Retaining ring	2		
41	101.05-55	牙架座	Feed bar crank	1		
42	02-511400721-1	螺钉 SM11/64x40x7	Screw	1		
43	101.05-35	牙架组件	Feed bar asm.	1		
44	101.05-31	牙架销	Feed bar shaft pin	1		

5、送料部件/Feed mechanism components

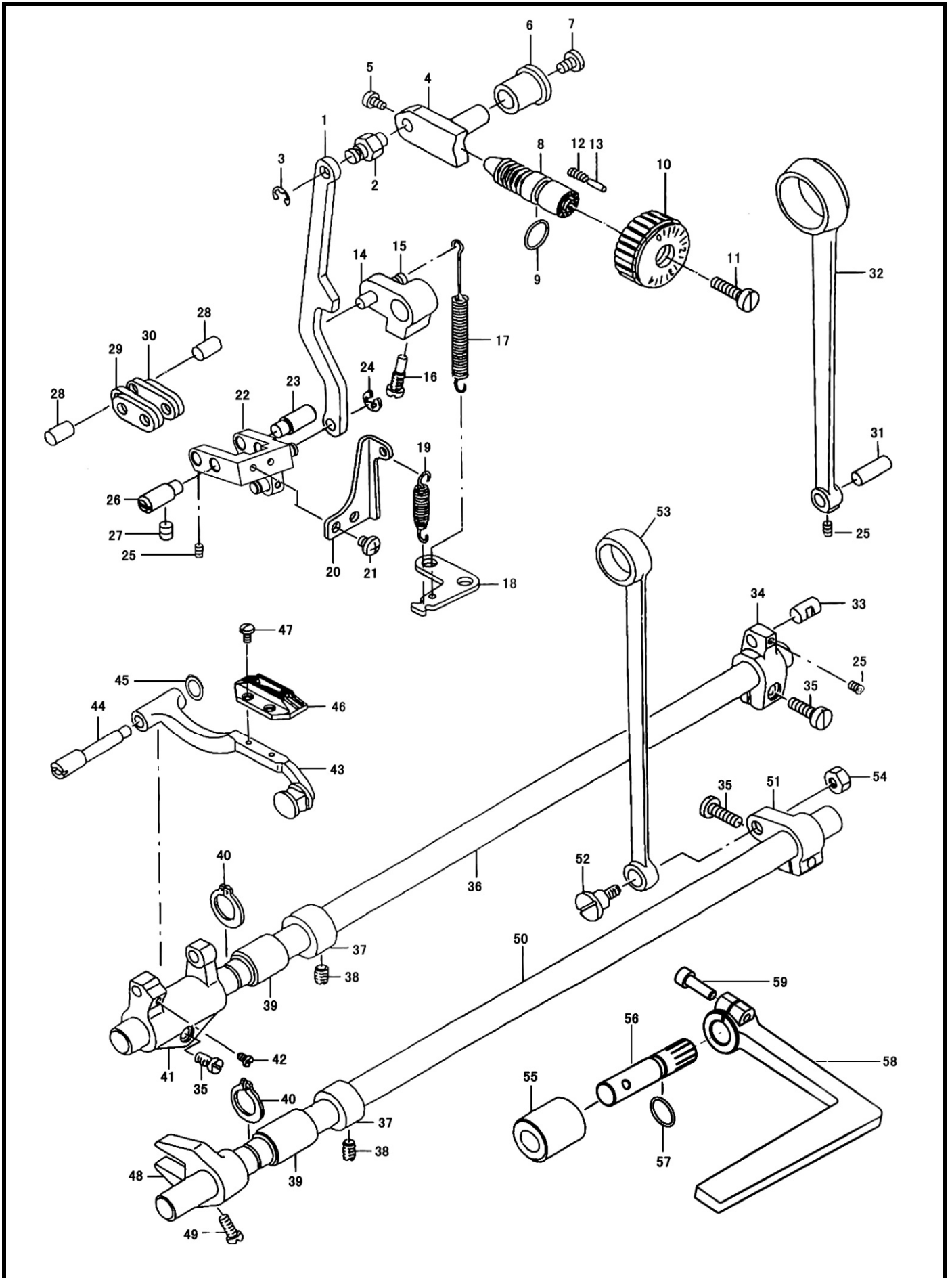

5、送料部件/Feed mechanism components

序号 Ref.No	图号 Part. No	零件名称	Name of parts	数量Qty		
				H8800DF -7C-5	H8800D -7C-5	H8800DH -7C-5
45	05-051081203-5	垫圈 $\phi 5.1 \times 0.8 \times \phi 12$	Washer	1		
46	110.05-33 (1.15)	送料牙	Feed dog		1	
	101.05-33	送料牙	Feed dog	1		
	116.05-34	送料牙	Feed dog			1
47	02-608440621-1	螺钉 SM1/8x44x6	Screw	2		
48	101.05-57	抬牙叉形曲柄	Driving shaft crank	1		
49	02-411401121-1	螺钉 SM11/64x40x11	Screw	1		
50	101.05-48	抬牙轴	Feed driving shaft	1		
51	101.05-45	抬牙后曲柄	Lifting crank (back)	1		
52	101.05-47	螺钉	Hinge screw	1		
53	101.05-15	抬牙连杆	Connecting rod	1		
54	04-618280400-1	螺母 SM9/32x28x4	Nut	1		
55	102.05-65	倒送料轴套	Feed lever bushing	1		
56	101.05-63	倒送料轴	Feed reverse shaft	1		
57	12-062240	O型圈 $\phi 6.2 \times \phi 2.4$	Rubber ring	1		
58	102.05-68	倒送料扳手	Reverse feed control lever	1		
59	01-505001624-1	螺钉 M5x16	Screw	1		

6.自动切线/Thread trimmer components

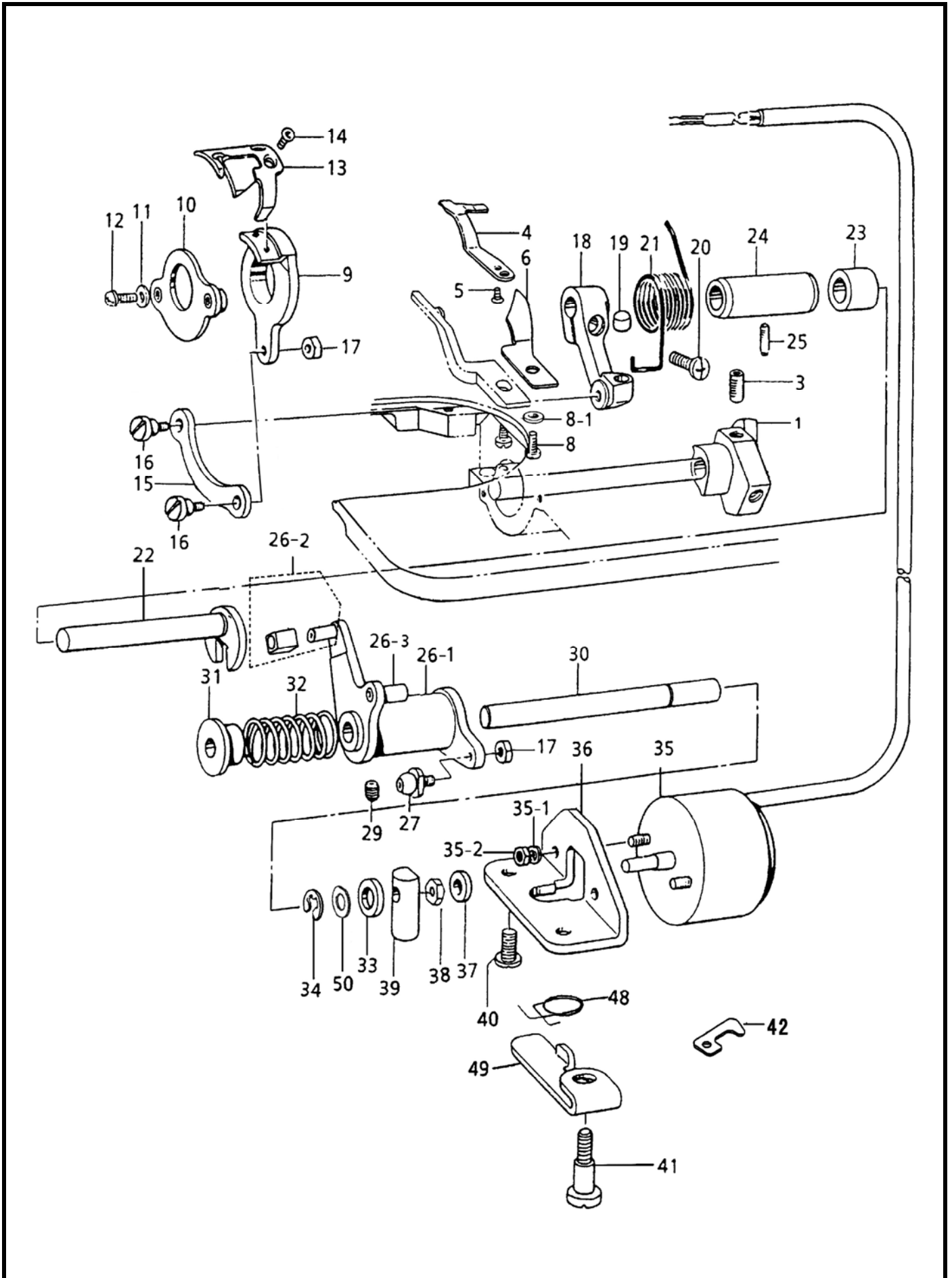

6.自动切线/Thread trimmer components

序号 Ref.No	图号 Part. No	零件名称	Name of parts	数量Qty		
				H8800DF -7C-5	H8800D -7C-5	H8800DH -7C-5
1	103.11-01G	切线凸轮	Thread shear cam	1		
3	02-816401014-1	螺钉	Screw	2		
4	102.06-04	固定刀	Secant knife	1	1	
	116.06-03N	固定刀	Secant knife			1
5	02-109400621-1	螺钉	Screw	1		
6	102.06-06	分线器	Protect needle patch	1		
8	02-509400521-1	螺钉	Screw	1		
8-1	05-043080900-1	分线器螺钉垫片	Washer	1		
9	102.06-09	剪线刀架	Knife bracket	1		
10	102.06-10	刀架压板组件	Partiality shank asm.	1		
11	05-045080900-4	刀架压板螺钉垫片	Washer	2		
12	02-411401223-1	螺钉	Screw	2		
13	102.06-13	活动刀	Motorial knife	1	1	
	102.06-13G	活动刀	Motorial knife			1
14	02-111400524-1	螺钉	Screw	2		
15	102.06-15	刀轴连杆	Knife shaft connecting rod	1		
16	102.06-16	连杆螺钉	Screw	2		
17	04-611400300-1	螺母	Nut	2		
18	102.06-18G	切刀驱动曲柄	Thread shear rock crank	1		
19	103.11-09-06G	驱动曲柄止动块	Positioning block	1		
20	02-512321421-1	螺钉	Screw	1		
21	102.06-21	切线曲柄弹簧	Spring	1		
22	102.06-22	切刀驱动曲柄轴	Thread shear rock arm shaft	1		
23	102.06-23	驱动曲柄轴短套	Short bush	1		
24	102.06-24	切线轴套	Thread shear cam bushing	1		
25	02-811400614-1	螺钉	Screw	1		
26-1	102.06-26-1	切线凸轮曲柄	Thread shear rock arm shaft	1		
26-2	102.06-26-2-0	滑块轴组件	Slippery piece shaft asm.	1		
26-3	102.06-26-3	切线限位轴	Limit potential shaft	1		
27	102.06-27-0	滚柱轴组件C	Roll shaft asm.	1		
29	02-816400514-1	螺钉	Screw	1		
30	102.06-30	切刀驱动轴	Thread shear shaft	1		
31	102.06-31	扭簧端盖	Spring cover	1		
32	102.06-32	切线凸轮复位弹簧	Spring	1		
33	102.06-33	电磁铁缓冲垫	Magnetic plug cushion mat	1		
34	06-0601012-1	挡圈	E-ring	1		
35	QD-13-E	切线电磁铁	Thread trimmer solenoid	1		
35-1	102.06-35-1	切线电磁铁弹垫	Spring washer	2		
35-2	03-604000400-4	螺母	Nut	2		
36	102.06-36	切线电磁铁支架	Thread trimmer solenoid base	1		
37	102.06-37	橡胶垫	Rubber ring	1		
38	04-606400400-1	螺母	Nut	1		
39	102.06-39	切线电磁铁顶销	Thread trimmer solenoid pin	1		
40	02-315280921-1	螺钉	Screw	1		
41	102.06-41	螺钉	Screw	1		
42	101.06-20	电磁铁导线压板	Solenoid press plate	1		
48	102.06-48	弹簧	Spring	1		
49	102.06-49	松线座	Thread loose seat	1		
50	05-081101550-1	垫片 $\phi 8.1 \times 1 \times \phi 15.5$	Washer	1		

7.自动倒缝部件/Automatic reverse feed components

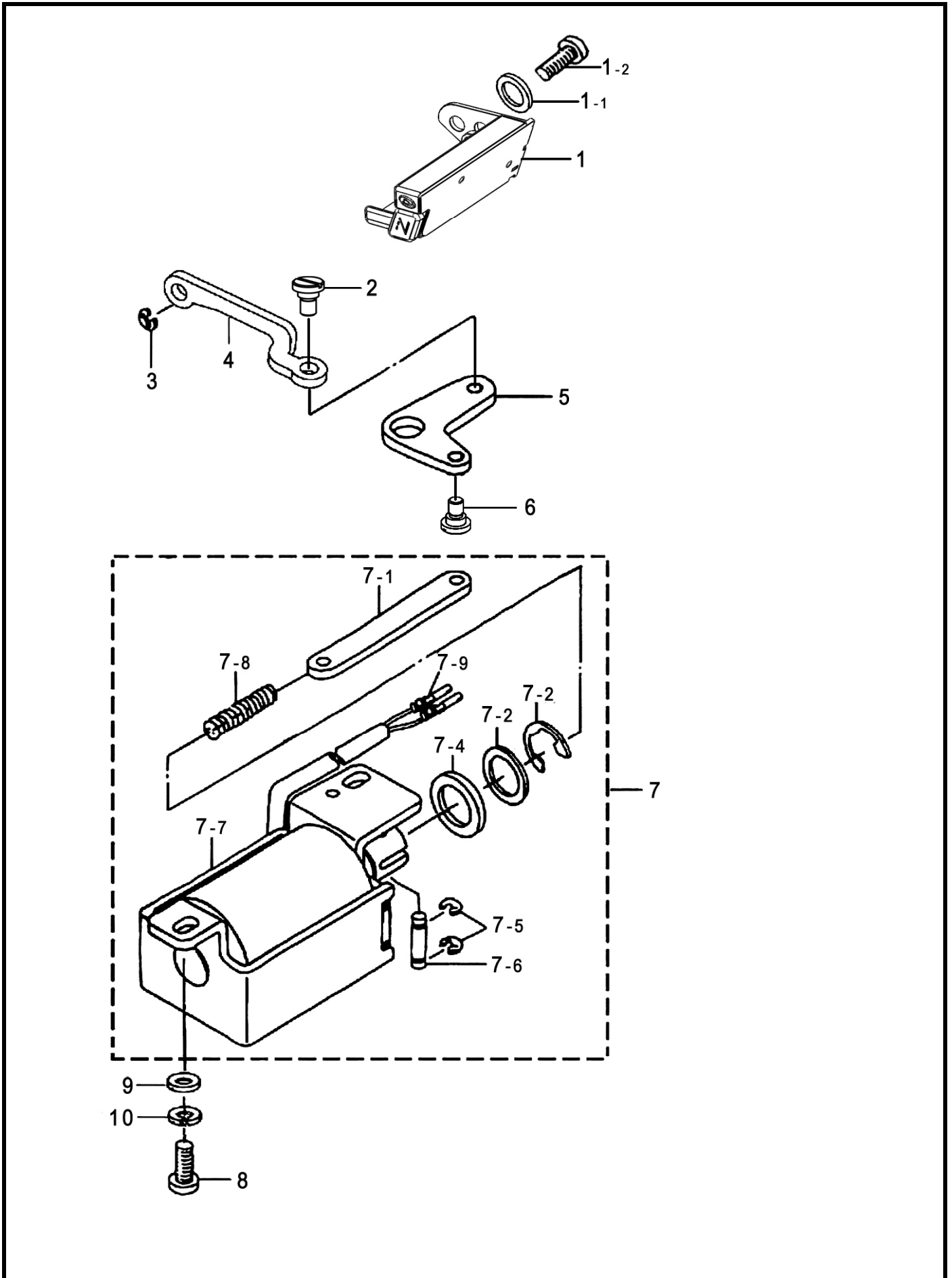

7.自动倒缝部件/Automatic reverse feed components

序号 Ref.No	图号 Part. No	零件名称	Name of parts	数量Qty		
				H8800DF -7C-5	H8800D -7C-5	H8800DH -7C-5
1	DL13-01/01	倒缝照明灯组件	Reverse switch asm.	1		
1-1	05-053101000-1	平垫片	Washer	2		
1-2	01-405001423-1	螺钉M5×8	Screw	2		
2	101.07-06-05	轴位螺钉	Shaft screw	2		
3	06-0500611-1	挡圈 φ5x0.6xφ11	E-ring 5	1		
4	101.07-04G	自动倒送料拉杆	Reverse feed connecting sha	1		
5	101.07-06	倒缝曲柄	Connecting arm asm	1		
6	101.07-06-04	轴位螺钉	Shaft screw	1		
7	DD-13-E	自动倒缝组件	Reverse feed asm	1		
7-1	101.07-08-01	倒缝铁芯连杆	Reverse feed connecting link	1		
7-2	101.07-08-02	倒缝铁芯挡圈E12	E-ring 12	1		
7-3	101.07-08-03	垫片	Washer 16X24X2.6	1		
7-4	101.07-08-04	橡胶垫片	Rubber Plunger	1		
7-5	101.07-08-05	连接销卡簧	E-ring	2		
7-6	101.07-08-06	倒缝铁芯连接销	Plunger arm Pin	1		
7-7	101.07-08-07	倒缝电磁铁	Reverse feed magnet asm.	1		
7-8	101.07-08-08	连杆定位簧	Plunger spring	1		
7-9	101.07-08-09	导线插针	pin contact	2		
8	02-715281521-1	螺钉 SM15/64x28x15	Screw	2		
9	05-064161200-1	平垫 φ6.4x1.6xφ12	Washer	2		
10	07-0631616-1	弹垫 φ6.3x1.6x1.6	Spring washer	2		

8. 驱动部件/Driver components

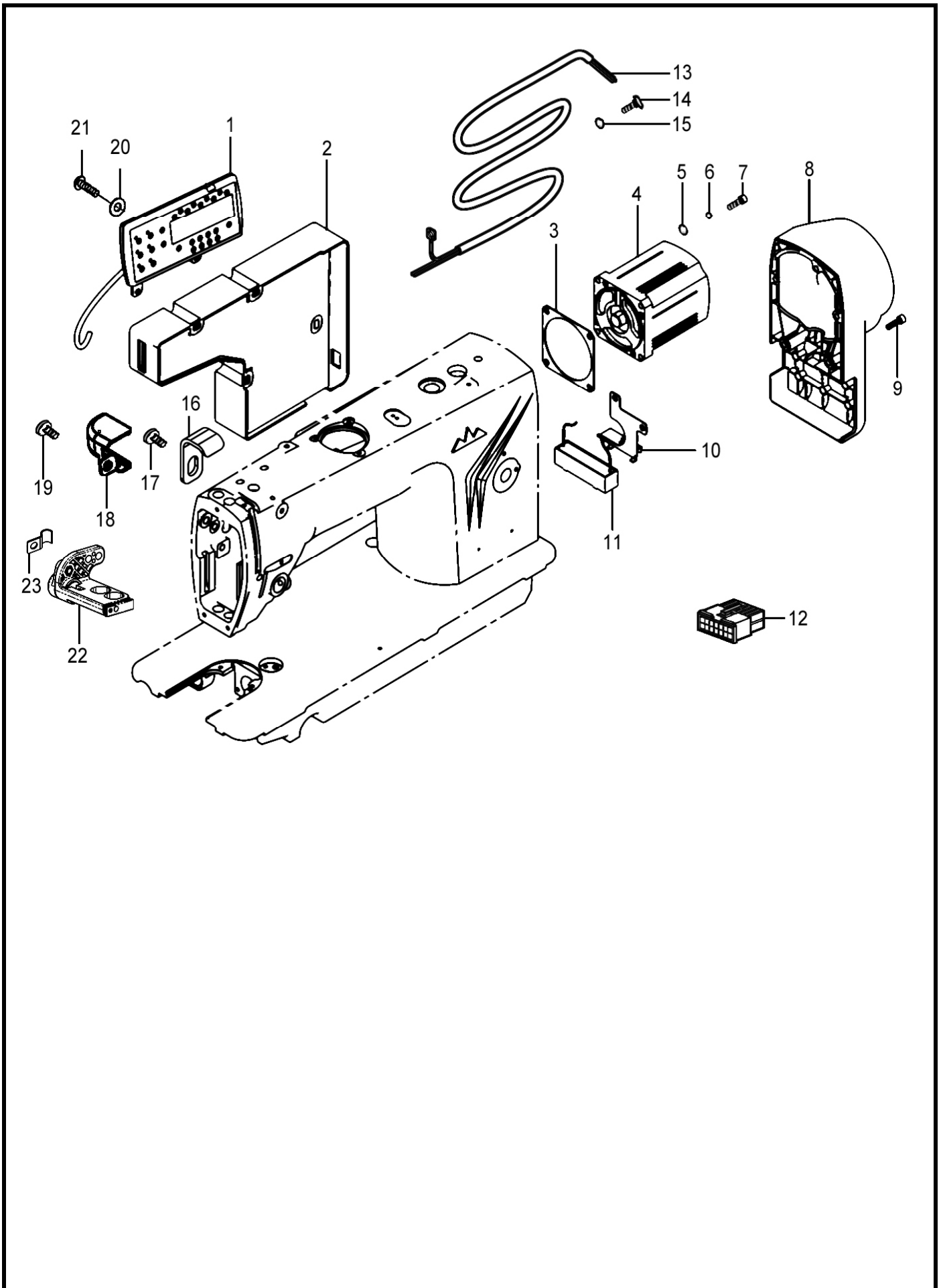

8.驱动部件/Driver components

序号 Ref.No	图号 Part. No	零件名称	Name of parts	数量Qty		
				H8800DF -7C-5	H8800D -7C-5	H8800DH -7C-5
1	CP13-00	操作面板组件	Control panel asm.	1		
2	CB13-00/02	电控组件	Control asm.	1		
3	102.11-41	步进电机垫片	Washer	1		
4	MO-13B-550/01	直驱电机组件	Motor asm.	1		
5	07-0521313-1	电机安装螺钉弹垫	Spring washer	4		
6	05-053101000-1	螺钉垫片	Washer	4		
7	02-512321824-1	螺钉	Screw	4		
8	102.11-34G	电机罩	Motor cover	1		
9	01-505001624-1	螺钉	Screw	5		
10	122.11-35	电阻压板	Brake resistance platen	1		
11	30008454	刹车电阻	Brake resistance	1		
12	113.15-05	插头	Connector	1		
13	CB13-06-0A0	电控电源输入线	Power cord	1		
14	02-412320821-1	螺钉 SM3/16x32x8	Screw	1		
15	08-0510610-1	波形垫圈 φ5.1x0.6x1	Wave washer	1		
16	124.14-12	过线夹	Clamp	1		
17	02-412280623-1	螺钉SM3/16"×28×6	Screw	1		
18	124.11-01	电线罩	Wire cover	1		
19	02-412281223-1	螺钉	Screw	2		
20	05-053101000-1	平垫片	Washer	4		
21	02-412281823-1	螺钉SM3/16"×28×18	Screw	4		
22	124.08-01-00	起针夹线器组件	Thread tension solenoid asm.	1		
23	113.01-07	线夹	Clamp	1		

9、润滑·绕线部件/Oil lubrication components&bobbin components

序号 Ref.No	图号 Part. No	零件名称	Name of parts	数量Qty		
				H8800DF -7C-5	H8800D -7C-5	H8800DH -7C-5
1	102.09-36	夹线器组件	Thread tension asm.	1		
1-1	102.09-36-01	夹线螺母	Nut	1		
1-2	102.09-36-02	夹线螺钉	Screw	1		
1-3	102.09-36-03	夹线簧	Spring	1		
1-4	102.09-36-04	夹线板	Thread tension disk	2		
1-5	04-611400300-1	螺母 SM11/64x40x3	Thread tension guide	1		
2	101.09-01	油窗	Oil sight window	1		
3	12-190265	油窗O型圈	Rubber ring	1		
4	102.09-34	切刀	Knife	1		
5	02-509400421-1	螺钉 SM9/64x40x4	Screw	2		
6	02-312320722-3	螺钉 SM3/16x32x7	Screw	3		
7	102.09-32	绕线器组件	Bobbin winder unit	1		
8	102.09-42	绕线轮垫圈	Washer	1		
9	101.09-06	回油管组件	Oil return tube asm.	1		
9-1	101.09-06-01	回油管	Oil return tube	1		
9-2	101.09-06-02	回油管毡	Return to asphalt felt	1		
9-3	101.09-06-03	回油管夹	Holder	1		
10	101.09-05	回油毡夹	Oil felt presser	1		
11	02-412320821-1	螺钉 SM3/16x32x8	Screw	1		
12	102.09-37	绕线驱动轮	Bobbin winder driving wheel	1		
13	02-811400811-1	螺钉 SM11/64x40x8	Screw	2		
14	101.09-03	上轴供油管	Main shaft oil tube	1		
15	101.09-13A	油泵连接螺柱	Oil pump support,large	1		
16	06-0901018-1	卡簧 $\phi 9 \times 1 \times \phi 18$	E-ring	1		
17	02-511401021-1	螺钉 SM11/64x40x10	Screw	1		
18	101.09-11	油泵组件	Lubricating oil pump asm.	1		
18-1	101.09-11-01	油泵安装板	Oil pump installing base	1		
18-2	101.09-11-02	油泵体	Oil pump	1		
18-3	101.09-11-03	油泵叶轮	Oil pump impeller	1		
18-4	101.09-11-04	油泵盖螺钉	Screw	3		
18-5	101.09-11-05	油泵盖	Lubricating oil pump cover	1		
18-6	101.09-11-06	油泵叶轮托板	Oil pump impeller cover	1		
18-7	101.09-11-07	回油柱塞	Plunger	1		
18-8	101.09-11-08	柱塞簧	Plunger spring	1		
18-9	101.09-11-09	柱塞螺钉	Plunger screw	1		
18-10	101.09-11-10	下轴供油管	Hook driving shaft oil tube	1		
18-11	101.09-11-11	螺钉	Screw	3		
19	02-515281321-1	螺钉 SM15/64x28x13	Screw	1		
20	101.09-16	供油管接头	Rubber joint	1		
21	102.09-11	旋梭供油管	Oil tube	1		
22	102.09-09	旋梭油量调节螺钉	Oil adjusting screw	1		
23	102.09-10	旋梭油量调节簧	Spring	1		
24	101.09-07	送料轴油线	Oil wick	1		

10.油盘部件/Oil reservoir components

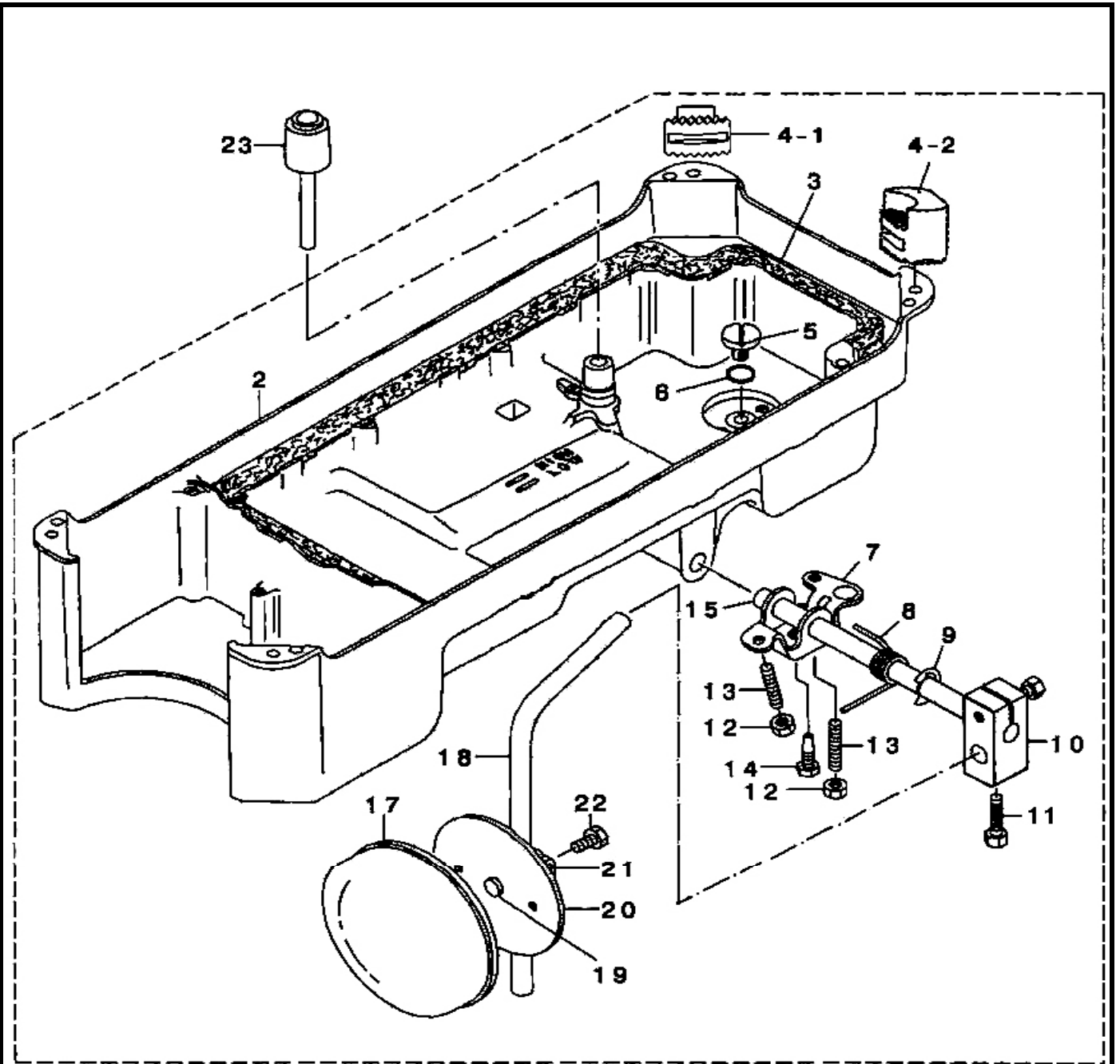

10.油盘部件/Oil reservoir components

序号 Ref.No	图号 Part. No	零件名称	Name of parts	数量Qty		
				H8800DF -7C-5	H8800D -7C-5	H8800DH -7C-5
2	101.10-01	油盘	Oil reservoir	1		
3	101.10-02	油盘垫	Oil reservoir gasket	1		
4-1	101.14-13	防震垫小	Quakeproof mat,small	2		
4-2	101.14-12	防震垫大	Quakeproof mat,larger	2		
5	02-620240721-1	螺钉	Screw	1		
6	12-062240	排油孔螺钉O型圈	Rubber ring	1		
7	101.10-05-01	抬压脚双向曲柄	Knee lifting rotating arm	1		
8	101.10-05-02	双向曲柄扭簧	Spring	1		
9	06-1001020-1	抬压脚轴开口挡圈	E-ring	1		
10	101.10-05-04G	抬压脚操纵杆节头	Vertical shaft fitting arm	1		
11	01-708001425-4	操纵杆节头螺钉	Screw	2		
12	03-606000350-4	双向曲柄限位调节螺母	Nut	2		
13	01-806003021-4	双向曲柄限位调节螺钉	Screw	2		
14	01-706001735-4	双向曲柄螺钉	Screw	1		
15	101.10-05-09	抬压脚轴	Knee press cross shaft	1		
17	101.10-06-01	操纵板软垫	Knee pan plate cover	1		
18	101.10-06-02	操纵杆	Knee pan upright shaft	1		
19	101.10-06-03	操纵杆垫	Knee pan plate rubber	1		
20	101.10-06-04	操纵板	Knee pan plate	1		
21	101.10-06-05	操纵杆节头	Knee pan plate support	1		
22	01-706001025-4	节头螺钉	Screw	1		
23	101.10-07	抬压脚顶销	Knee lifter push pin	1		

11.附件/Accessories

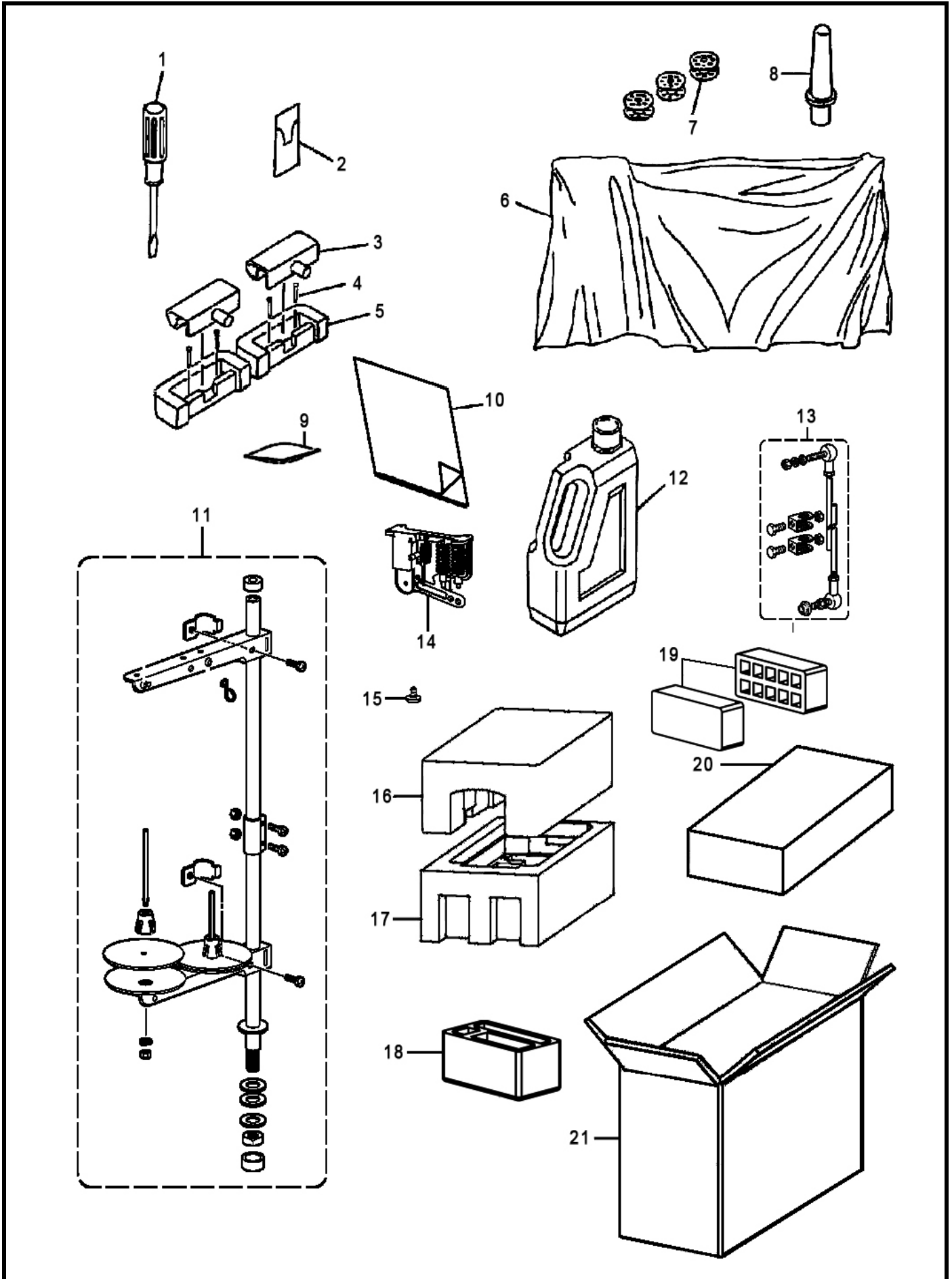

11.附件/Accessories

序号 Ref.No	图号 Part. No	零件名称	Name of parts	数量Qty		
				H8800DF -7C-5	H8800D -7C-5	H8800DH -7C-5
1	113.16-19	两用螺丝刀	Screw driver	1		
2	101.03-11	机针	Needle		5	
	101.12-11-01-03	机针	Needle	5		
	101.12-11-24	机针	Needle			5
3	101.14-01	机头连接钩	Machine hinge plate asm.	2		
4	101.14-02	机头连接钩座钉	Nail	4		
5	101.14-03	机头连接钩座	Machine hinge plate	2		
6	101.14-08	机头罩	Macgube head cover	1		
7	101.03-37-02	梭心	Bobbin	3		
8	122.14-09A	机头支柱	Macgube rest cover	1		
9	101.12-20	空气干燥剂	Air drier	1		
10	124.13-01	产品说明书及零件手册	Instruction manual&parts book	1		
11	101.12-01	过线架组件	Thread stand asm.	1		
12	101.14-10	油箱	Oil reservoir asm.	1		
13	M-02F-010	活球连杆组件	Live festival ball link asm.	1		
14	KS-13Z/01	控速器组件	Treadle asm.	1		
15	21-3501932-4	十字半圆头木螺钉	Screw	4		
16	124.10-01-01	上泡沫	Foam mat (top)	1		
17	124.10-01-02	下泡沫	Foam mat (bottom)	1		
18	124.10-01-03	中泡沫	Foam mat (middle)	1		
19	124.10-04	附件箱泡沫垫	Foam mat	1		
20	124.10-03	内箱	Inside box	1		
21	124.10-02	外箱	Outside box	1		

12.H8800DB不锈钢板机型专用件/ H8800DB Faceplate stainless steel model

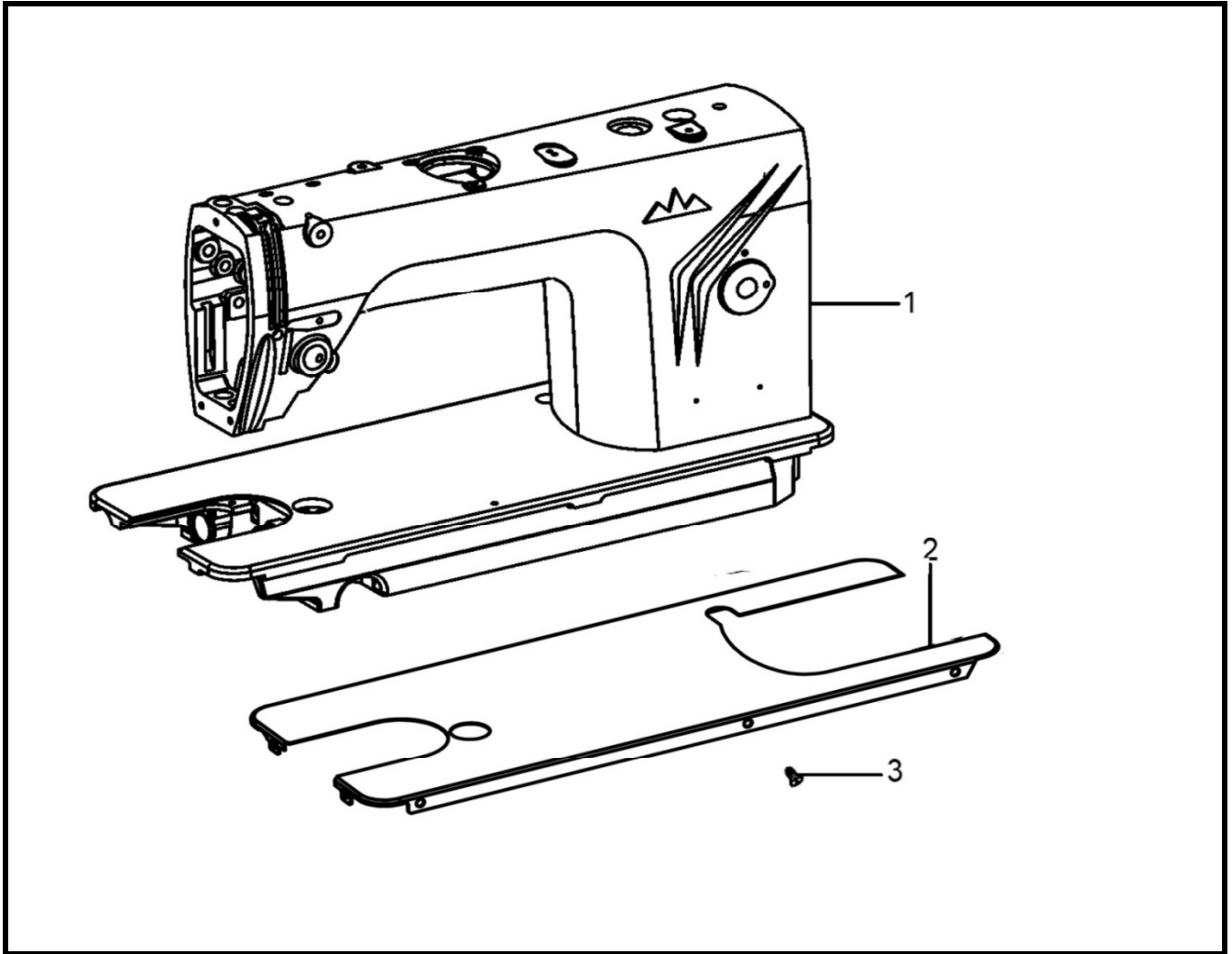

12.H8800DB不锈钢板机型专用件/ H8800DB Faceplate stainless steel model

序号 Ref.No	图号 Part. No	零件名称	Name of parts	数量Qty
				H8800DB□-7C-5
1	124.01-01G	机壳组件	Machine cover	1
2	102.01-76	防磨装饰板	Faceplate stainless steel	1
3	02-211400821-1	螺钉	Screw	6

13、电磁抬压脚装置(选配件)/ Presser foot lifting set mechanism(Option parts)

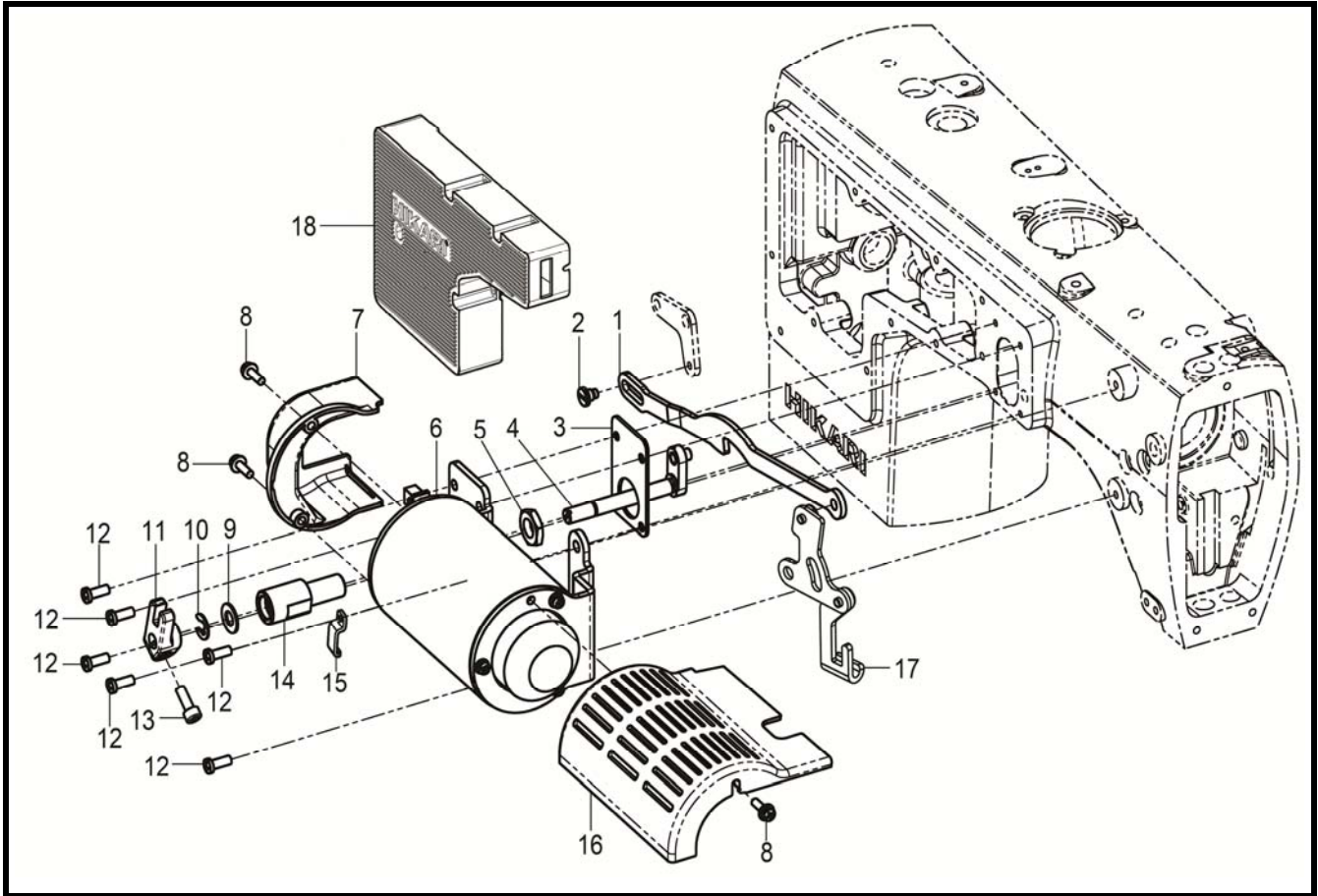

13、电磁抬压脚装置(选配件)/ Presser foot lifting set mechanism(Option parts)

序号 Ref.No	图号 Part No	零件名称	Name of parts	数量Qty
				H8800D□-7C-5/AK
1	124.14-01	膝控抬压脚连杆	Knee lifting cross rod	1
2	124.14-09	肩轴螺钉	Shoulder screw	1
3	124.14-04	密封垫	Gasket	1
4	124.14-05	自动抬压脚曲柄轴	Presser foot lifting winch shaft	1
5	03-61615080-1	螺母M16×1.5	Nut,M16×1.5	1
6	124.14-02	抬压脚电磁铁组件	Presser foot lifting asm.	1
7	124.14-07-01	电磁铁罩	Cover	1
8	18-404001423-3	螺钉	Screw	3
9	05-081101603-5	平垫圈D8.1×16×1.0	Washer	1
10	06-0700814-4	开口挡圈 7	E-ring	1
11	124.14-06	自动抬压脚曲柄	Presser foot lifting crank	1
12	02-412281223-1	螺钉	Screw	6
13	01-505001424-1	螺钉	Screw	1
14	124.14-03	曲柄轴套	Bushing	1
15	103.18-04	线夹	Clamp	1
16	124.14-07-02	电磁铁罩	Cover	1
17	124.04-39	前杠杆组件	Knee lifting cross rod asm.	1
18	CB13-00/03	电控组件	Control asm.	1